

Maximum Efficiency UPS Protection in an Intelligent, Low TCO Design
Liebert® eXL™ UPS 625-1200kVA, Single Module and Multi-Module Systems



A UPS as Dynamic as Your Data Center

The Liebert® eXL™ UPS maximizes operational and capital efficiency, enabling today's dynamic data centers to be rapidly deployed, flexible and easily scalable—all without sacrificing the availability or reliability your business requires. This UPS solution enables simple, intuitive operation and proactive service and maintenance.

Be Prepared for Today's and Tomorrow's Challenges with the Liebert eXL UPS:



Efficient, High-Density Design and Operation

Maximizes both operational and capital efficiency.



Flexible Configurations and Design

Enables today's dynamic data centers to be rapidly deployed, flexible and easily scalable.



Intuitive, Intelligent Operation

Simple to use, with easy access to controls and information, and helps to avoid costly downtime associated with human error.



Designed for Easy Service and Maintenance

Provides easy access to all unit components—reducing maintenance and repair time.



Proactive remote service delivery

Allows Emerson Network Power to anticipate, identify, diagnose and fix problems before they escalate.



Liebert eXL UPS, 1200kVA/kW

What's Your Challenge?

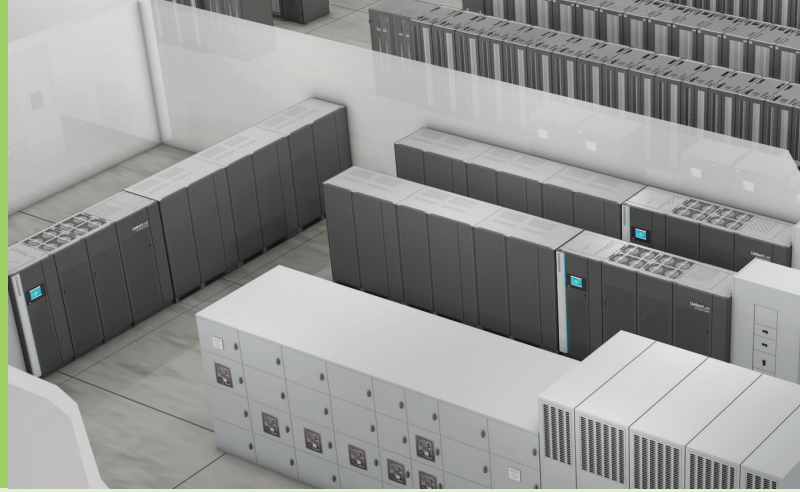

At Emerson Network Power, we design power solutions to help meet the challenges of dynamic data centers.

If you're experiencing any of these common data center obstacles, the Liebert® eXL™ UPS is the power solution you're looking for:

Reducing operating expenses and energy costs

Liebert eXL UPS provides: Operational Efficiency

- Up to 97% efficient in double conversion mode
- 6th generation IGBTs
- 3-level inverter/rectifier
- Eco-mode ready

Difficulty predicting future power requirements and planning for change

Liebert eXL UPS provides: Flexible Configurations and Scalable Capacity

- 625-1200 kVA/kW, SMS and 1+N
- Capacity-on-demand scalability

Operating with a lean staff yet needing more visibility into data center power status

Liebert eXL UPS provides: Intelligent Information and Control

- Large, intuitive full-color touch-screen HMI shortens training cycles
- *Trellis*™ platform ready
- Integrated battery monitoring
- Proactive maintenance and support with LIFE™ Services

Fulfill demanding service level agreements

Liebert eXL UPS provides: Robust Design

- Starts up fully-rated transformer loads
- Short circuit withstand rating 65kA standard, 100kA optional
- Fault clearing
- Leading power factor load support (0.7 leading/0.7 lagging)
- Powerful 400kW power cores (largest in the industry)
- HRG compatible
- Redundant control scheme

Limited physical space

Liebert eXL UPS provides: Infrastructure Optimization

- Small footprint
- Light weight
- Input PF >99%, THDi ≤5%
- 480V, 3-wire design reduces installation costs and size

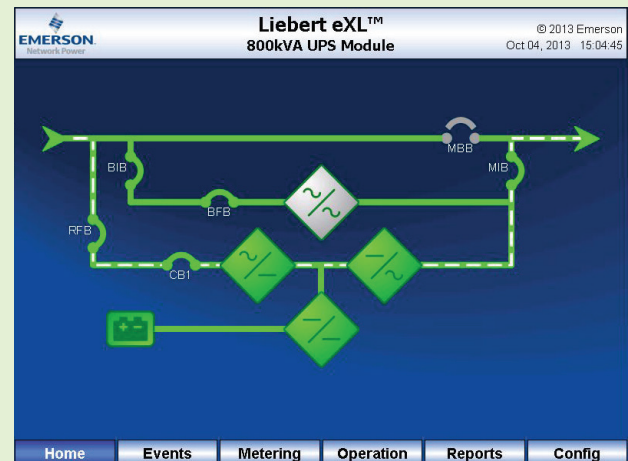

The large, on-unit HMI touch screen (10.4") provides comprehensive, real-time updates of critical system information.

Reduce Costs with Efficient, High-Density Design and Operation



Reducing energy consumption—and driving down operating expenses, PUE and TCO—is on the mind of many data center professionals.

Industry-Leading Efficiency

To help achieve this goal, the Liebert® eXL™ UPS utilizes a transformer-free topology with up to **97%** efficiency in double conversion mode, helping to optimize your PUE. And each Liebert eXL UPS is eco-mode ready, providing you future options for enhancing data center efficiency.

Meanwhile, our tested and proven designs, featuring architectures that both engineers and users trust, help to ensure that you can obtain high levels of efficiency without sacrificing availability or uptime.

Do More with Less

Because many of today's data center face physical space restraints, the Liebert eXL UPS provides high capacity in a smaller footprint, delivering more usable power, best space utilization, and reduced installation costs.

Scalable Capacity to Keep Pace with Growth

Leveraging SoftScale technology, the Liebert eXL UPS can seamlessly add capacity as your business needs expand—without increasing physical footprint. This helps to avoid unnecessary upfront capital outlays on extra capacity.

Conserve Capital with Capacity-on-Demand

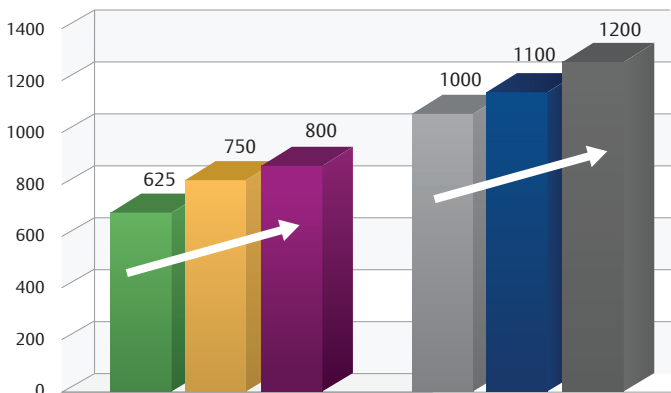

The Liebert eXL UPS can grow from 625 - 800kVA or 1000-1200kVA without increasing footprint. Using SoftScale™ technology, you can preserve up-front capital and easily add capacity-on-demand to respond to dynamic business needs. You purchase only the capacity you need, when you need it.

Liebert eXL UPS Efficiency Curve

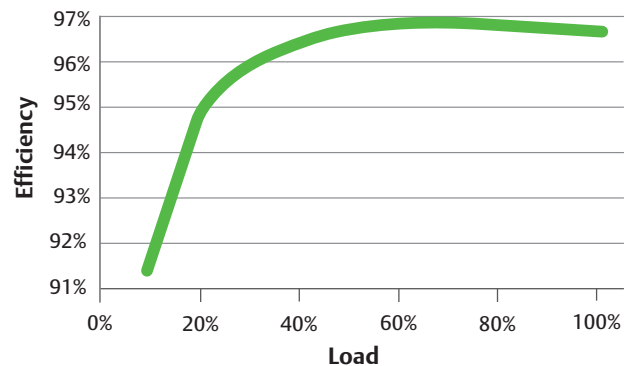

1% Higher Efficiency = ~\$10,000 Annual Savings per MW*

*Based on \$0.10/kWh, reduced heat rejection and reduced cooling load.

Deploy Faster with the Liebert eXL UPS

The Liebert eXL UPS enables faster deployment through:

- **Light weight and small footprint**, allowing the UPS to fit easily into available space and flooring--and making it ideal for deployment on prefabricated skids.
- **Optional matching battery cabinets with internal bussing**, reducing wiring and offering factory-integrated Albér® Battery Monitoring.
- **Three-wire design**, eliminating the need for neutral and providing compatibility with aluminum conductors if desired.
- **High input power factor with low THDi** draws more kW from a given source, and allows for smaller breakers, feeders, and generators and for quicker expansion and upgrades.

Meet Changing Business Needs with Flexible Configurations and Design



Business is accelerating. Needs and objectives are changing faster than ever. To help your data center keep pace, the Liebert® eXL™ UPS facilitates rapid deployment through flexible configurations and easy scalability.

Multiple Configurations to Fit Your Challenges

The Liebert eXL UPS offers **both single module and multi-module configurations in a selection of kVA ratings**, allowing you to deploy the same technology in a variety of applications.

Single-module Configuration

Single-module Liebert eXL UPS configurations provide basic protection with high levels of efficiency. The critical bus is powered by a single Liebert eXL UPS system with bypass capability. Large capacity modules can replace multiple smaller modules in dual bus configurations, reducing complexity and increasing reliability.

Multi-Module (1+N Parallel) Configuration

The Liebert eXL UPS can also provide multi-module operation without the need for a system control cabinet. Multi-module Liebert eXL UPS configurations utilize paralleling of single units to offer easy scalability for capacity or redundancy. Each unit has its own bypass static switch; bypass sharing is assured through integral bypass load sharing inductors, which also help simplify wiring and installation.

And, with a high input power factor and low input harmonics, the Liebert eXL eliminates the need to oversize the generator.

Dual Bus or 2N

A dual bus system features two identical UPS systems and supporting power systems, each capable of carrying the full load. During normal operation the two systems support the load. Each system may have redundancy built-in to maintain redundancy while one system is offline.

Reserve or Catcher Bus with Liebert STS2 Static Transfer Switches

Creates a redundant overall system architecture, and can be created with downstream power distribution similar to a dual bus 2N architecture. Liebert STS 2 static switches with Optimized Transfer ensure that your critical load is fully protected. This configuration allows the UPS to operate at higher utilization rates, while providing a highly fault tolerant power system design.

Single Module System (SMS) Tier 1

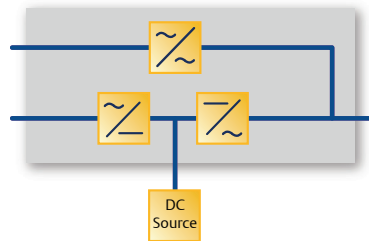

Distributed Bypass (1+N)
Parallel up to 6 modules

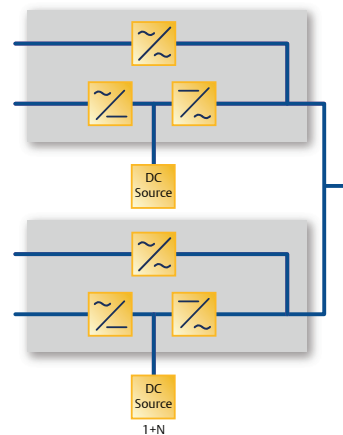

Dual Bus 2N Tier 2-4

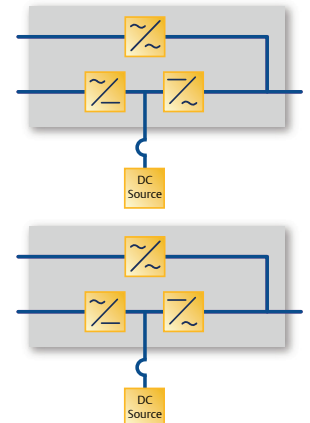

Catcher Bus/ Reserve
Bus Tier 3-4

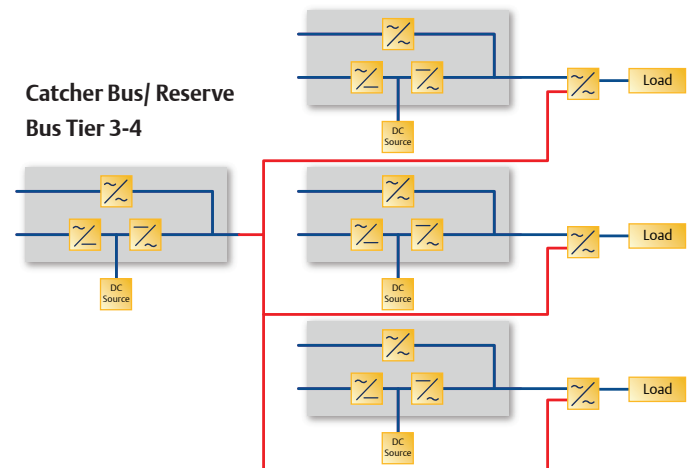

Intuitive, Intelligent Operation



Intelligent technologies make the Liebert® eXL™ UPS easy to use, and enhance visibility and availability. The integrated controls, available battery monitoring, and DCIM compatibility enable a system that keeps you informed and in control.

Simpler Operation through Intuitive HMI

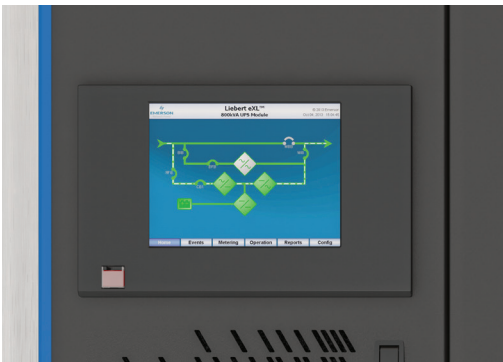

The Liebert eXL UPS utilizes a 10.4” color touch-screen control to enable easier operation and maintenance, reduce training requirements and place metering, alarms and diagnostics at your fingertips. Visual indications of the solution’s status can be viewed at a glance, with detailed numerical information accessible on demand. The streamlined interface means that users can quickly and painlessly navigate through all controls to find the information and settings that they need.

Real-Time Control and Information

Liebert eXL UPS is compatible with the *Trellis™* platform, to enable real-time monitoring and management of your entire power environment. Using these solutions, you can visualize the operating state of all devices as well as the dependencies that exist between them, all in a single diagram. This provides simple, comprehensive and real-time data to help you make fast, sound decisions to ensure power is maintained at all times.

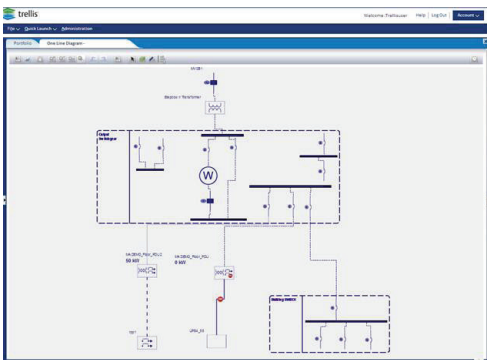

Trellis™ Power System Manager – Comprehensive view into power system resource utilization and capacity.

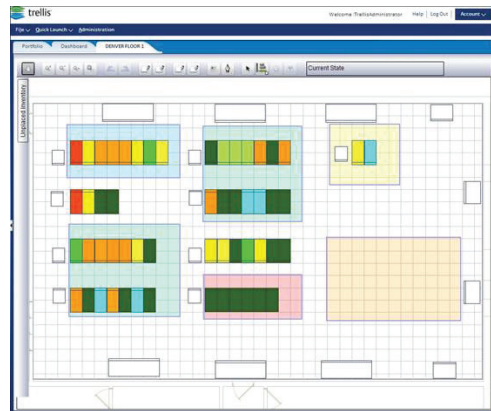

Trellis™ Inventory Manager – Real-time, inventory to every asset’s floor or rack position.

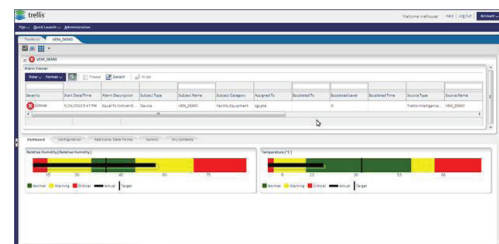

Trellis™ Site Manager – Detailed data about the environment’s operating status and site conditions.

Be Confident That Your Batteries Will Be Available When You Need Them Most

Proactively Avoid Battery Failures

Since UPS battery failures continue to be the primary cause of unplanned data center outages, Liebert® eXL™ battery cabinets are available with factory installed and tested Albér® BDSUi™ battery monitoring systems. The Albér BDSUi continuously monitors all critical battery parameters and provides advance warning of a preventable battery failure as well as enables battery maintenance and replacement to be based on the condition of the batteries

rather than arbitrarily timed schedules. Utilizing its patented DC resistance battery testing method, the Albér BDSUi battery monitoring systems gives customers real-time visibility across an entire battery system by verifying the integrity of the entire system including the internal cell, inter-cell, inter-tier, and mid-string disconnect switch resistances.

SEE

Helps you proactively address battery related issues that you could never see before by allowing you to visualize all critical information and know the real state of health of your batteries at all times (in real-time or historical trending).

DECIDE

Helps you make more informed decisions, faster by analyzing data and utilizing built-in decision support functions that determine what matters and what doesn't.

ACT

Helps you take the right action with confidence at the right time by recommending the best corrective action.

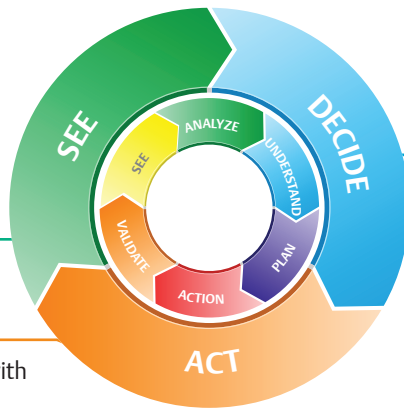

Albér battery monitoring provides the ability to make smarter and faster decisions resulting in higher availability, reduced maintenance and replacement costs, and ultimate confidence in your batteries.

Battery Xplorer Screens

System View

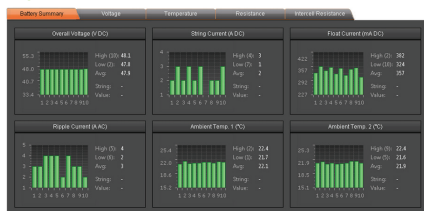

View data on parallel battery strings simultaneously.

String View

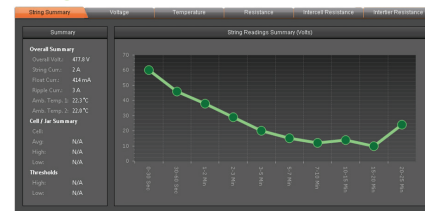

View a trend graph showing the history of all the string level parameters

Alarm View

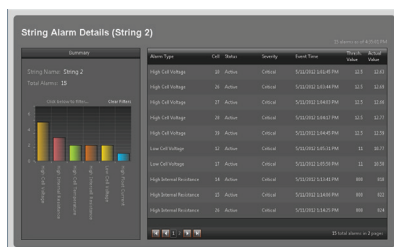

View active alarms in a sortable and customizable grid.

Discharge View

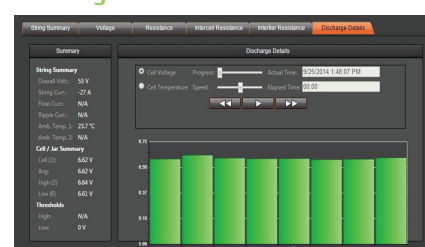

View data captured during a discharge event

Simplify Service, Maintenance and Operations



The Liebert® eXL™ UPS provides easy access to all unit components—reducing maintenance and repair time.

Large User-friendly HMI Touch Screen

What our Customers Say: “The HMI is by far the best of all the ones we have seen.”

Simplifies use with easy access to controls and information

Common Building Block Construction

Simplifies repairs and streamlines spare parts and support management

Easy Access Design

What our Customers

Say: “You can tell that it was designed for serviceability.”

Reduces maintenance and repair time

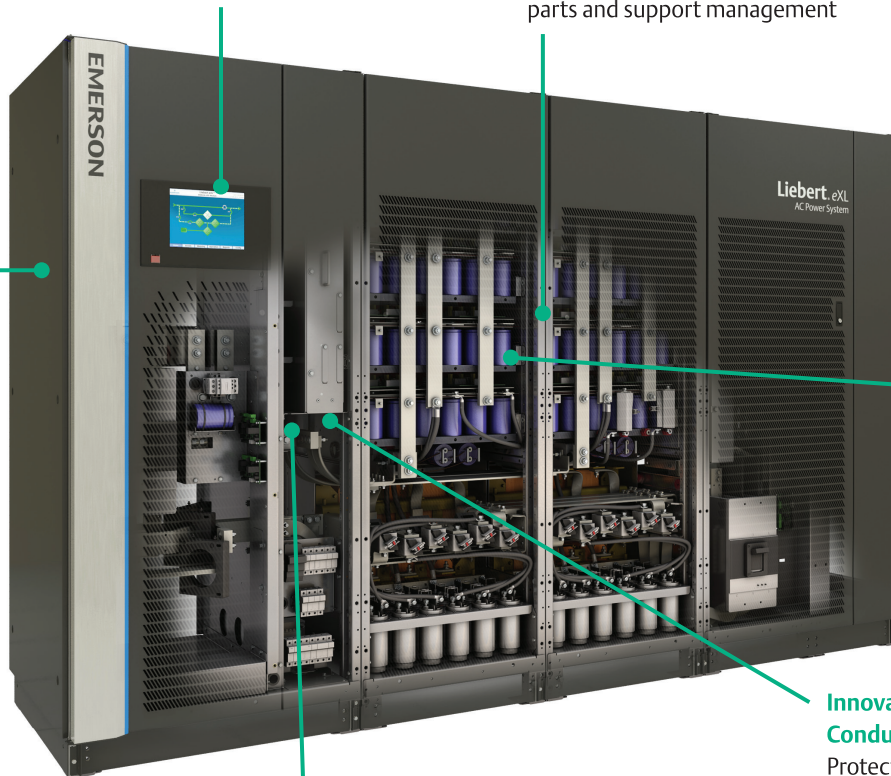

Modular Assemblies on Pull-out Slides

Simplifies access and increases ease of service

Innovative Articulated Conduit

Protects low voltage cabling from tangling, pinching, and shorting during service

Integrated Control System and Internal Diagnostics

Allows enhanced visibility into operation and awareness of potential issues

Liebert eXL UPS, 800kVA/kW

The Liebert eXL UPS is purposely designed for superior serviceability. Easy access to key components, along with our common building block construction reduces mean time to repair and saves valuable time and money.

With service from Emerson Network Power, customers have 24x7 access to a network of data center infrastructure specialists armed with the knowledge and parts needed to resolve problems—anytime and anywhere.



LIFE™ Services

With LIFE Services, Emerson Network Power provides continuous remote diagnostics and proactive service dispatch for Liebert® eXL™ UPS. Our experts use advanced service level data and IP-based communications to anticipate, identify, diagnose and respond to problems before they can cause downtime or hinder performance.

Doing so, we can help your team save time and focus on strategic tasks while improving productivity and reducing unplanned outages. All communication is out-bound only to minimize or eliminate the risk of security breaches.

With LIFE services, you will benefit from:

Uptime assurance: Constant monitoring of equipment parameters maximizes the system's availability.

First Time Fix Rate: Pro-active monitoring and data measuring ensure that when our customer engineers are dispatched on-site, they arrive prepared for first time resolution.

Proactive Analysis: From LIFE Service centers, our experts proactively analyze the data and trends of your equipment to recommend actions that ensure their best performance.

Minimized Total Cost of Ownership of Your Equipment: The continuous monitoring of all relevant parameters in turn maximizes unit performance, reduces on-site maintenance and extends the life of your equipment.

Fast Incident Response: LIFE allows for immediate definition of the best course of action, as a result of the regular communication between your system and our LIFE Service centers.

Reporting: You will receive a comprehensive report detailing the working order of your equipment and its operational performance.

With Emerson Network Power services there are no third-party patchwork routines with can affect security and control. Customers receive a direct connection to factory-trained professionals.

Service and Support from Emerson Network Power

Emerson Network Power provides the industry's largest service network, ensuring that data center expertise is never far when you need it. From strategy to deployment, operation and expansion, our team can help you optimize your data center for efficiency and availability with:

- System-level factory witness testing to provide assurance that crucial power systems work together before site installation.
- The largest network of factory-trained local service and support in the industry. Expertise is never far away when you need it, whether it be during strategy, deployment or operation.
- Factory-direct service technicians to help protect your investment and optimize performance.

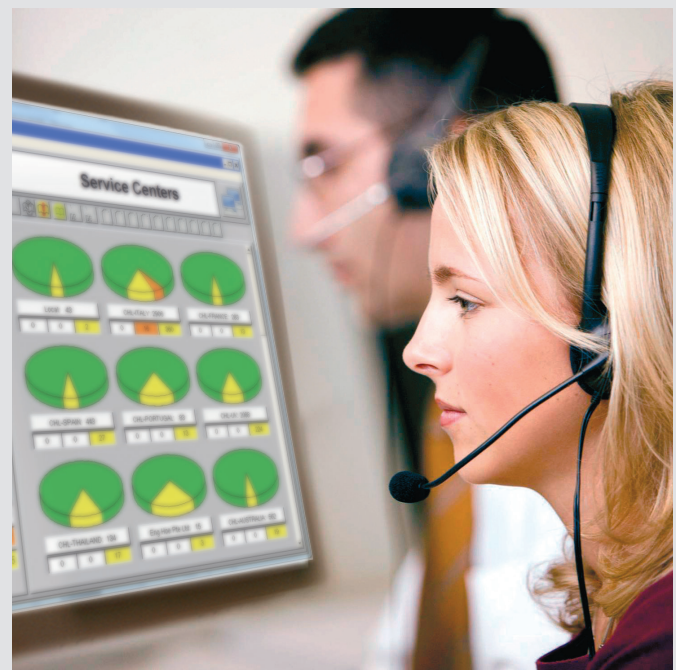

Designed and Built for Efficiency and Flexibility

Battery cabinets for the Liebert® eXL™ UPS are built to facilitate fast deployment, easy serviceability and long operational life. Select from your choice of leading battery manufacturers. Configurations for conventional top terminal and high-capacity front terminal type batteries.

- Direct-Connect capability to attach directly to the left side of the UPS module for a clean, compact installation.
- Internal bussing to reduce field wiring and associated installation costs and time.
- Seismic anchoring.
- Individual circuit breakers for each cabinet, for easy, safe servicing and selective cabinet isolation in over-temperature or fault conditions.
- Optional factory integrated Albér Battery Monitoring System.
- Batteries mounted on pull-out drawers for safe, easy servicing.

Flexible Battery Cabinets and Configurations



Top Terminal Battery Cabinet



Front Terminal Battery Cabinet

Intelligent Design and Construction Extends Throughout the Liebert eXL UPS

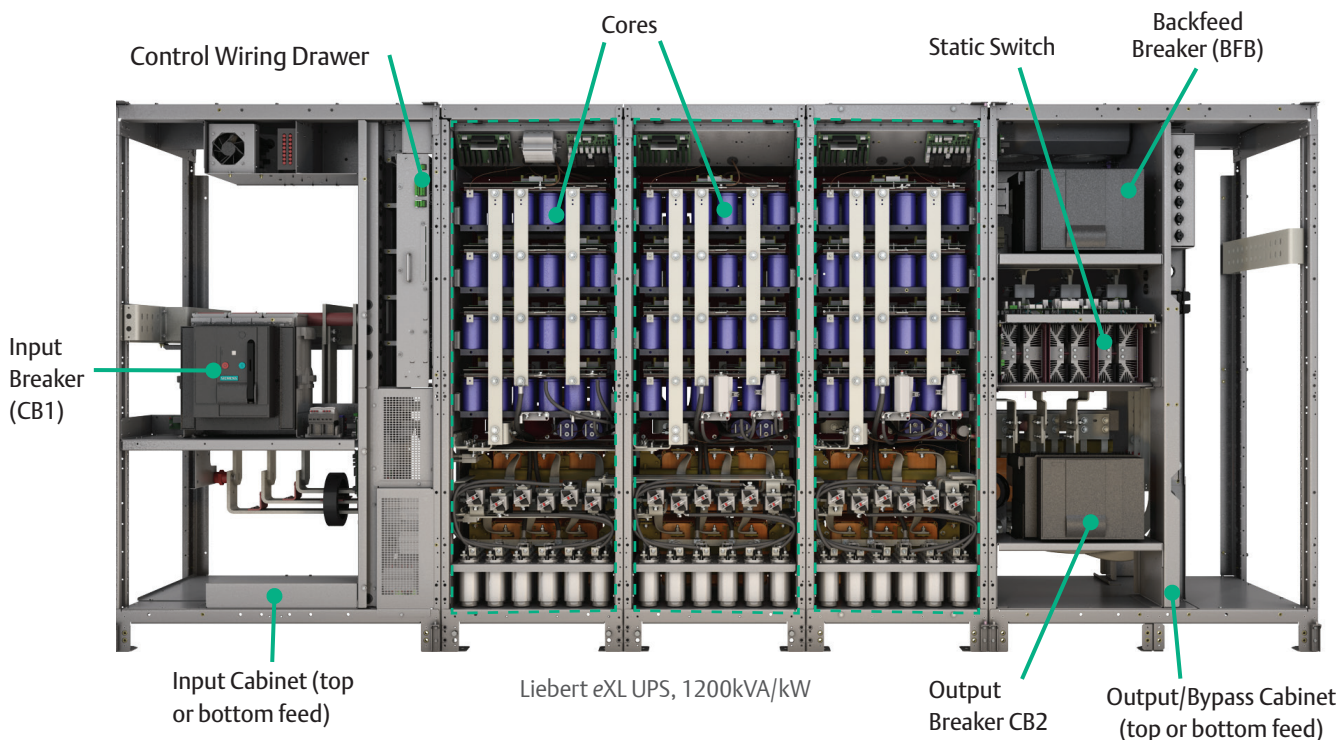

World Class Witness Test Capability Improves Speed of Deployment

Factory Witness Testing Ensures Performance While Facilitating Deployment

The Liebert Power Systems Test Center for large UPS systems is a state-of-the-art test facility designed to provide customers with pre-installation testing of the performance, interoperability, and efficiency of Liebert UPS modules and systems under a variety of conditions. Located in Delaware, Ohio, the 25,600 square-foot facility, including a 2,600 square-foot customer observation station, is the largest and most comprehensive in the industry.

Testing includes individual modules as well as the complete power system and is essential to the smooth, rapid installation and commissioning of large power systems. Customers leave the Liebert Power Systems Test Center with documented proof and confidence that their complex power system will operate seamlessly in accordance with business-critical availability requirements.

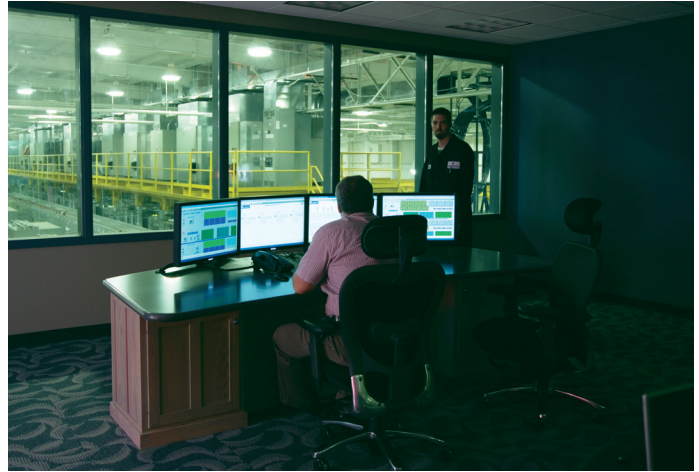

Product Specifications

Liebert® eXL™ UPS Model Size	625, 750, 800 kVA / kW	1000, 1100, 1200 kVA / kW
Input AC Parameters		
Rectifier Type	IGBT Active Rectifier	
Input Voltage to Rectifier	VAC 480 3-phase, 3-wire	
Input Voltage to Bypass	VAC 480 3-phase, 3-wire	
Input Voltage Range	VAC +10%, -15% (-30% battery assist)	
Input Frequency, Hz	60	
Permissible Input Frequency Range, Hz	55 to 65	
Input Power Factor	>0.99	
Reflected input THDi at nominal voltage at full load %	<5%	
Power Walk-In, sec	1 to 30 (selectable) in 1 sec. increments	
Battery & DC Parameters		
Battery Type	VRLA (Valve Regulated Lead Acid) or FLA (Flooded Lead Acid)	
Nominal Battery Bus, VDC	480V	
Battery Float Voltage, VDC	540V	
DC Ripple Voltage in Float and Const V Ch. mode, %	<1 (RMS value) < 3.4% Vpp	
Temperature Compensated Battery Charging	Standard (with temperature probe)	
Output Parameters		
Inverter Type	High Efficiency Transformer Free IGBT PWM Controlled Inverter	
Output Power, kVA/kW	625, 750, 800 kVA / kW	1000, 1100, 1200 kVA / kW
Load Power Factor Supported (Without Derating)	0.7 Leading to 0.7 Lagging	
Output Voltage	480 VAC 3-phase, 3-wire	
Output Voltage Regulation	< 1% (3-phase RMS average)	
Output Voltage Regulation (50% Unb. Load)	< 2% (3-phase RMS average)	
Output Frequency, Hz	60 Hz	
Output Frequency Regulation, %	± 0.1%	
Output THD at Nominal Voltage (Linear Load), %	3%	
Output THD at nominal voltage Including a 100kVA Non Linear Load per IEC 62040-3, %	<6% (max)	
Efficiency AC-AC Double Conversion	up to 97%	
Transient Recovery	IEC 62040-3, section 5.3.1 Figure 1	
Voltage Displacement	120 deg +/- 1 deg (50% unbalanced load)	
Unbalanced loads current capacity	50% of nominal phase current	
Overload	110% for 10 minutes, 125% for 2 minutes, 150% for 15 seconds, 200% for 10cycles	
Physical Characteristics Single Module System		
Width, Depth, Height in inches (mm)	125.2 in x 33.5 in x 76.8 in (3145 mm x 850 mm x 1950 mm)	171.7 in x 33.5 in x 76.8 in (4330 mm x 850 mm x 1950 mm)
Weight, unpackaged, lbs (kg)	5,735 lbs. (2,601 kg.)	8,050 lbs. (3,660 kg.)
Color	Black, RAL 7021	
Protection Class, UPS Enclosure	NEMA 1, IP 20 (with and without front door open)	
Standards		
Safety	UL 1778 4th Edition; CSA 22.2 107.3	
Surge	ANSI C62.41 B3	

Emerson Network Power Global Headquarters

1050 Dearborn Drive
P.O. Box 29186
Columbus, Ohio 43229
800 877 9222 Phone (U.S. & Canada Only)
614 888 0246 Phone (Outside U.S.)
Contact@EmersonNetworkPower.com

Emerson Network Power Caribbean and Latin America

Office – United States of America
+1-954-984-3452 Phone
Ask.Cala@Emerson.com

Emerson Network Power Canada

3580 Laird Rd Unit 1
Mississauga
Ontario L5L 5Z7
+1 905 569 8282
Ask@EmersonNetworkPower.com

liebert.com

24 x 7 Tech Support

800 222 5877 Phone
614 841 6755 (outside U.S.)

EmersonNetworkPower.com

While every precaution has been taken to ensure accuracy and completeness in this literature, Liebert Corporation assumes no responsibility, and disclaims all liability for damages resulting from use of this information or for any errors or omissions. All rights reserved throughout the world. Specifications subject to change without notice.

All names and logos referred to herein are trade names, trademarks or registered trademarks of their respective owners. © Liebert is a registered trademark of the Liebert Corporation.

SL-26001 (R02/15) Printed in USA

Emerson, Consider it Solved, Emerson Network Power and the Emerson Network Power logo are trademarks and service marks of Emerson Electric Co.

©2015 Emerson Electric Co.