

### AC Output<sup>1</sup>

|                    |   |
|--------------------|---|
| <b>12 kW</b>       | 60 Hz, 1800 RPM, 1 Ph, 1.0 PF,<br>120-240 V/50A, 120 V/100A |
| <b>10 kW</b>       | 50 Hz, 1500 RPM, 1 Ph, 1.0 PF,<br>220 V/45.4A               |
| Optional           | Three Phase with 0.8 PF                                     |
| Voltage regulation | ±1%   |

### Lugger L843 Engine

|              |                              |
|--------------|------------------------------|
| Type         | Vertical 3 cylinder diesel   |
| Displacement | 91 in <sup>3</sup> (1.5 ltr) |
| Bore/Stroke  | 3.30/3.5 in (84/90 mm)       |
| HP @ RPM     | 20.0/1800<br>17.0/1500       |

### Approx. fuel use

|                                   |                    |
|-----------------------------------|--------------------|
| 1800 RPM @ full load <sup>2</sup> | 1.2 gph (4.5 lph)  |
| 1800 RPM @ half load <sup>2</sup> | 0.62 gph (2.3 lph) |
| 1500 RPM @ full load <sup>2</sup> | 1.0 gph (3.8 lph)  |
| 1500 RPM @ half load <sup>2</sup> | .51 gph (1.9 lph)  |

### Installation Data & Weight

|                        |                   |
|------------------------|-------------------|
| Exhaust outlet         | 1.38 inch (35 mm) |
| Fuel inlet and return  | 1/4 inch NPT      |
| Approximate dry weight | 668 lbs (303 kg)  |

- Based on 1.0 unity power factor. Deratings: 3% per 1000 ft. over 500 feet above sea level. 1.5% for every 10° over 77°F
- Actual fuel consumption will vary depending on operating conditions.

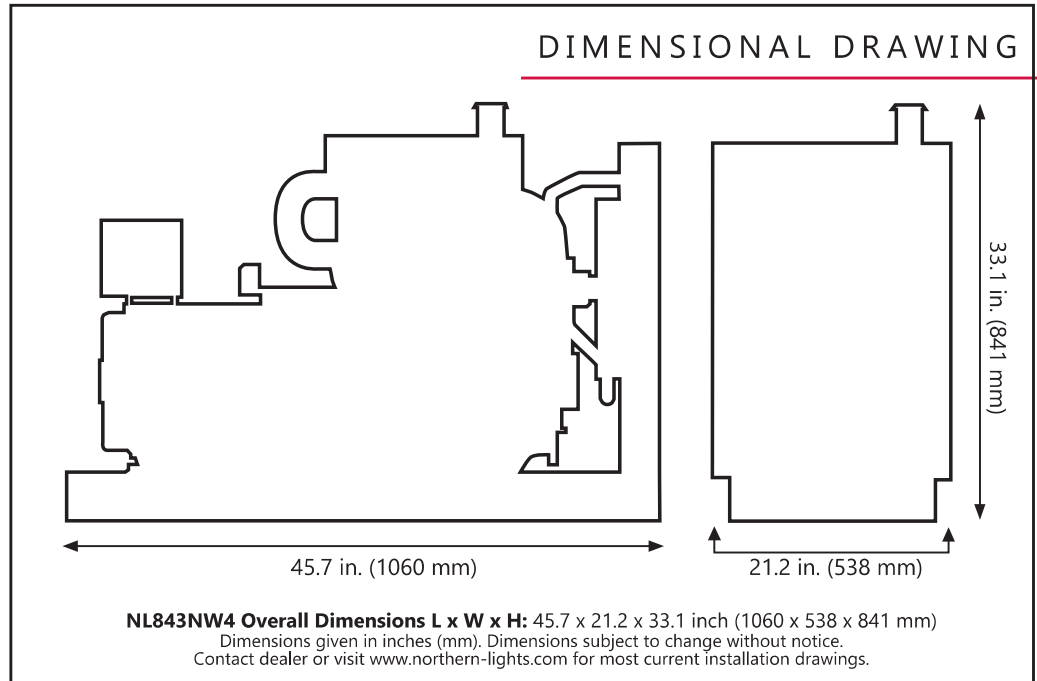

## NL843NW4 FEATURES AND BENEFITS

#### ENGINE BLOCK

- Four cycle, 3 cylinder, liquid cooled, naturally aspirated, overhead valve, industrial-duty diesel.
- Swirl combustion design improves fuel efficiency, reduces smoke and noise.
- Glow plugs for fast cold weather starting.

#### COOLING SYSTEM

- Liquid-cooled with radiator and pusher cooling fan. Steel radiator shroud and fan guard protects the radiator and operator.

#### SELF-VENTING FUEL SYSTEM

- Bosch-type in-line injection pump.
- Stop solenoid controls the fuel rack, not throttle, to eliminate speed variance and linkage problems.
- Engine speed governed to 5% for close AC frequency control.
- Pintle fuel injectors have replaceable tips for lower service costs.
- Mechanical fuel pump with hand primer.
- Large spin-on fuel filter.
- Fuel line manifold and flexible fuel lines for easy fuel tank connection.

#### LUBRICATION SYSTEM

- Full flow, spin-on oil filter with bypass.
- 5.8qt. (5.5ltr) oil capacity for better lubrication.

#### INTAKE AND EXHAUST

- Large replaceable air filter protects engine in dusty environments.
- Residential muffler built into the exhaust manifold saves installation time and costs.
- Set meets US EPA Tier IV emission requirements for cleaner air.

#### DC ELECTRICAL SYSTEM

- 12 volt system includes starter motor, battery charging alternator with solid state voltage regulator and DC circuit breaker.
- Standard, unit mount S-1B control panel has engine hour meter, start-stop switch with run light and preheat switch.
- Dual panel relays and quick disconnect harness plug-ins. With optional Y-harness and 10, 20 or 40 foot harness extensions, you can have up to six remote control panels, up to 100 feet from the set.
- Safety shutdown system for low oil pressure and high coolant temperature.

#### AC GENERATOR

- Northern Lights, direct coupled, brushless AC generator end is maintenance free. 4 lead, 1 phase, 1.0 pf, 50 or 60 Hz output. 12 lead-3 phase output is optional. Conservative heat rise rating: 95°C/50°C ambient for long generator life.
- Automatic Voltage Regulator is powered by dedicated AC winding for true 300% short circuit capability. Quick ±1% RMS no load to full load voltage regulation. AVR has circuit breaker protection.
- Generator features high quality, Class "H" epoxy insulation, accessible diodes, over-sized bearings and junction box for wiring.
- High air flow from integral fan keeps generator running cool.

#### SPECIAL EQUIPMENT

- Welded steel skid frame gives rigid support and makes installation easy.
- Enhanced fan guard for improved operator safety.
- Flexible mounts isolate engine vibration for smooth operation.
- Long life, blue enamel paint finish.
- Operator's and parts manuals.
- Rigorous quality control includes a test run with load.
- Shipping crate protects set.

**TIER  
4**