

ASCO 7000 SERIES ATB

Automatic Transfer & Bypass-Isolation Switches J–design 150 through 600 amp

Operator's Manual

381333-307 C
6/2022

DANGER

DANGER is used in this manual to warn of a hazard situation which, if not avoided, will result in death or serious injury.

WARNING

WARNING is used in this manual to warn of a hazardous situation which, if not avoided, could result in death or serious injury.

CAUTION

CAUTION is used in this manual to warn of a hazardous situation which, if not avoided, could result in minor or moderate injury.

Refer to the outline and wiring drawings provided with your 7000 SERIES ATB for all installation and connection details and accessories.

Refer to *Group 5 Controller User's Guide* 381333–126 for ATS status display messages, time delays, pickup & dropout settings, and adjustments.

Rating Label

Each automatic transfer & bypass–isolation switch contains a rating label to define the loads and fault circuit withstand/closing ratings. Refer to the label on the Transfer Switch for specific values.

WARNING

Do not exceed the values on the rating label. Exceeding the rating can cause personal injury or serious equipment damage.

An experienced licensed electrician must install the ATB.



Table of Contents

Rating Label.....	1
Nameplate	3
Catalog Number Identification	3
Installation	3-9
Remove the Shipping Skid	3
Supporting Foundation	3
Mounting	3
Line Connections	3
Testing Power Conductors	3
Connecting Power Conductors.....	4
Controller Ground	4
Harnesses.....	4
Engine Starting Contacts.....	4
Auxiliary Circuits	4
Functional Test.....	4
Functional Test – Voltage Checks.....	5
Functional Test - -Electrical Operation	6
Testing & Service	7-8
Transfer Test	7
Preventive Maintenance.....	7
Replacement Parts	7
Disconnecting the Controller	7
Manual Load Transfer	7
Trouble-Shooting.....	8
Maintenance Handle.....	8
Bypassing & Isolating.....	9-15
Bypassing the ATS	9
Isolating the ATS	11
Return to Service.....	13
Index	16

Nameplate

The Transfer Switch nameplate includes data for each specific 7000 SERIES ATB. Use the switch only within the limits shown on this nameplate. A typical catalog number is shown below with its elements explained.

J 7ATB	C	3	400	N		5	C
Frame & SERIES	Neutral	Phase Poles	Amperes	Voltage		Controller	Enclosure
A-solid	B-switch C-overlapping blank- none	2-single	0150	A-115	J-400	5- standard 5X- if accessories ordered	C- Type 1 F- Type 3R G- Type 4 L- Type 12 blank- open type
B-switch		3-three	0200	B-120	K-415		
C-overlapping			0260	C-208	L-440		
blank- none			0400	D-220	M-460		
			0600	E-230	N-480		
				F-240	P-550		
				G-277	Q-575		
				H-380	R-600		

Catalog Number Identification

Typical 7000 SERIES ATB catalog no. for overlapping neutral, 3 pole, 600 amp, 480 V, ATB in Type 1 enclosure

Installation

ASCO 7000 SERIES Automatic Transfer & Bypass–Isolation Switches (7ATBs) are factory wired and tested. Field installation requires mounting and connection of service cables, and auxiliary control circuits (if required).

Remove the Shipping Skid

Open the enclosure's lower front door and also remove the lower rear access panel. Then remove the four lag screws (2 in front, 2 in rear) securing the enclosure to the shipping skid.

Supporting Foundation

The supporting foundation for the enclosure must be level and straight. Refer to the applicable enclosure outline drawing included with the switch for all mounting details including door opening space.

If bottom cable entry is used, the foundation must be prepared so that the conduit stubs are located correctly. Refer to the enclosure outline drawing for specified area and location. Provide cable bending space and clearance to live metal parts. When a concrete floor is poured, use interlocking conduit spacer caps or a wood or metal template to maintain proper conduit alignment.

Mounting

Refer to the applicable enclosure outline drawing furnished with this switch and mount the automatic transfer switch according to details and instructions shown on diagram.

Line Connections

Refer to the Wiring Diagram provided with the switch. All wiring must be made in accordance with the National Electrical Code and local codes.

Do not remove the barrier from the transfer switch. Always protect the transfer switch, bypass switch, and isolation contacts and mechanisms from construction grit and metal chips when cabling.



De-energize the conductors before making any line or auxiliary circuitry connections. Be sure that Normal and Emergency line connections are in proper phase rotation. Place engine generator starting control in the OFF position. Make sure engine generator is not in operation.

Testing Power Conductors

Do not connect the power conductors to the transfer switch until they are tested. Installing power cables in conduit, cable troughs and ceiling-suspended hangers often requires considerable force. The pulling of cables can damage insulation and stretch or break the conductor's strands. For this reason, after the cables are pulled into position, and before they are connected, they should be tested to verify that they are not defective or have been damaged during installation.



Protect the switch from construction grit and metal chips to prevent malfunction or shortened life of the 7ATB switch.

Installation

Connecting Power Conductors

After the power cables have been tested, connect them to the appropriate terminal lugs on the bypass switch as shown on the wiring diagram provided with the switch. Make sure the lugs provided are suitable for use with the cables being installed. Standard terminal lugs are solderless screw type and will accept the wire sizes listed on the drawings provided with the 7ATB. Be careful when stripping insulation from the cables; avoid nicking or ringing the conductor. Remove surface oxides from cables by cleaning with a wire brush. When aluminum cable is used, apply joint compound to conductors. Tighten cable lugs to the torque specified on rating label.

Controller Ground

A grounding wire must be connected to the controller's lower left mounting stud. Because the controller is mounted on the enclosure door, a conductive strap must be used between the enclosure and the door. This connection provides proper grounding which does not rely upon the door hinges.

Harnesses

The transfer switch is connected to the left side of the controller by a plug-in harness (two plugs).

Engine Starting Contacts

All customer connections, including the engine control contact connections, are located on terminal block TB which is mounted on the top right side of the enclosure. Refer to the wiring diagram provided with the automatic transfer switch and connect the engine start wires to the appropriate terminals. See Figure 1 and Table A.

Table A. Engine start connections.

When normal source fails	Terminals on transfer switch
contact closes	TB1 and TB2
contact opens	TB1 and TB3

Note: To temporarily disable engine control from the automatic transfer switch you can unplug J3 from the small P3 receptacle at the bottom of the assembly. Be sure to reconnect plug J3 to the P3 receptacle for automatic transfer switch operation.

Auxiliary Circuits

Connect auxiliary circuit wires to appropriate terminals on transfer switch terminal block TB as shown on the wiring diagram provided with this automatic transfer switch.

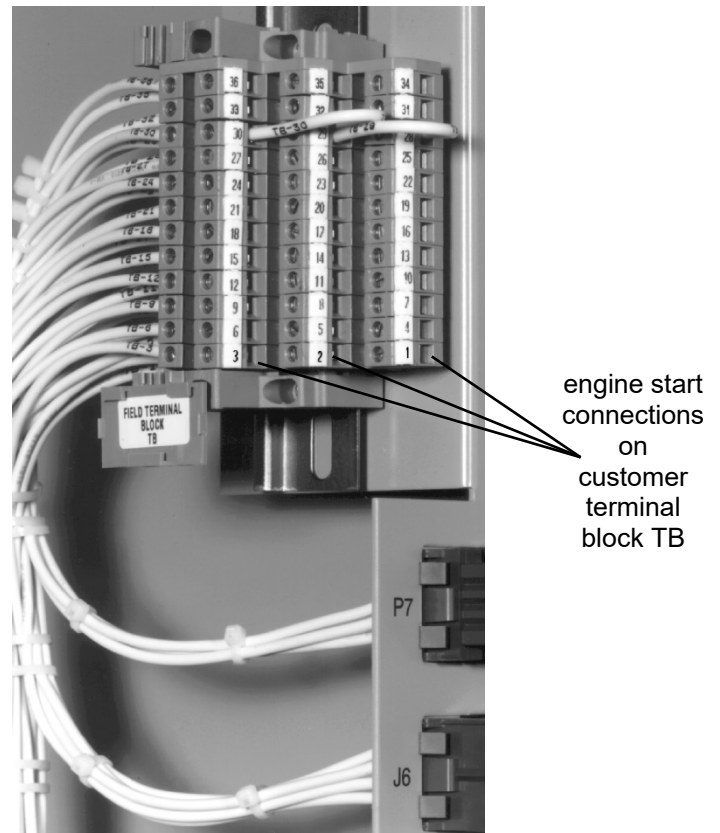

Figure 1. Customer terminal block on the top right side of the enclosure.

Functional Test

The Functional Test consists of two checks:

- 1 - Voltage Checks, page 5
- 2 - Electrical Operation, page 6



Do these checks in the order presented to avoid damaging the ATB.

Read all instructions on the Wiring Diagram and labels affixed to the automatic transfer switch. Note the control features that are provided and review their operation before proceeding.

Continue to **1 – Voltage Checks** on next page.

Installation

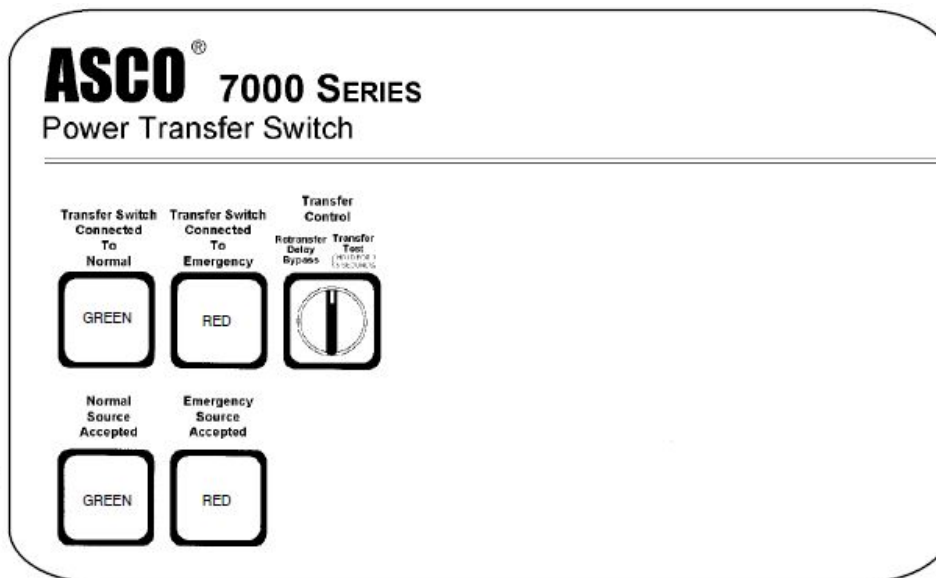

Figure 2. Standard controls and indicators.

Functional Test

Read all instructions on the *Wiring Diagrams* and labels affixed to the ATB. Note the control features that are provided and review their operation before proceeding.

After installing the 7ATB check the following:

- Bypass Handle should be in the *NORMAL* position.
- Isolation Handle should be in the *CONN* position.
- TS transfer switch Normal contacts should be C (closed), Emergency contacts should be O (open)

If handles are not in correct positions, follow instructions for Bypassing and Isolating the automatic transfer switch on pages 9-15. **Do not force the handles.** Electrical interlocks prevent a wrong sequence of operation.

1 – Voltage Checks

First check nameplate on transfer switch; rated voltage must be the same as normal and emergency line voltages.



Use extreme caution when using a meter to measure voltages. Do not touch power terminals; shock, burns, or death could result!

Perform steps 1 through 6 at the right. Observe the status lights. See Figure 2.

■ Black square means light is on.

□ White square means light is off.

* If necessary, adjust voltage regulator on generator per the manufacturer's recommendations. The ATB will respond only to rated voltage specified on the nameplate.

Now continue to 2 – **Electrical Operation** on next page.

1	Close the normal source circuit breaker. The <i>Transfer Switch Connected To Normal</i> and the <i>Normal Source Accepted</i> lights should come on.	
2	Use an accurate voltmeter to check phase to phase and phase to neutral voltages present at the transfer switch normal source terminals.	
3	Close the emergency source circuit breaker. (Start generator, if necessary.) The <i>Transfer Switch Connected To Normal & Emergency Source Accepted</i> lights should come on.	
4	Use an accurate voltmeter to check phase to phase and phase to neutral voltages present at the transfer switch emergency source terminals.*	
5	Use a phase rotation meter to check phase rotation of emergency source; it must be the <u>same</u> as the normal source.	
6	Shut down the engine-generator, if applicable. The <i>Emergency Source Accepted</i> light should go off. Then put the starting control selector switch (on the generator set) in the <i>automatic</i> position. Close enclosure door.	

Installation

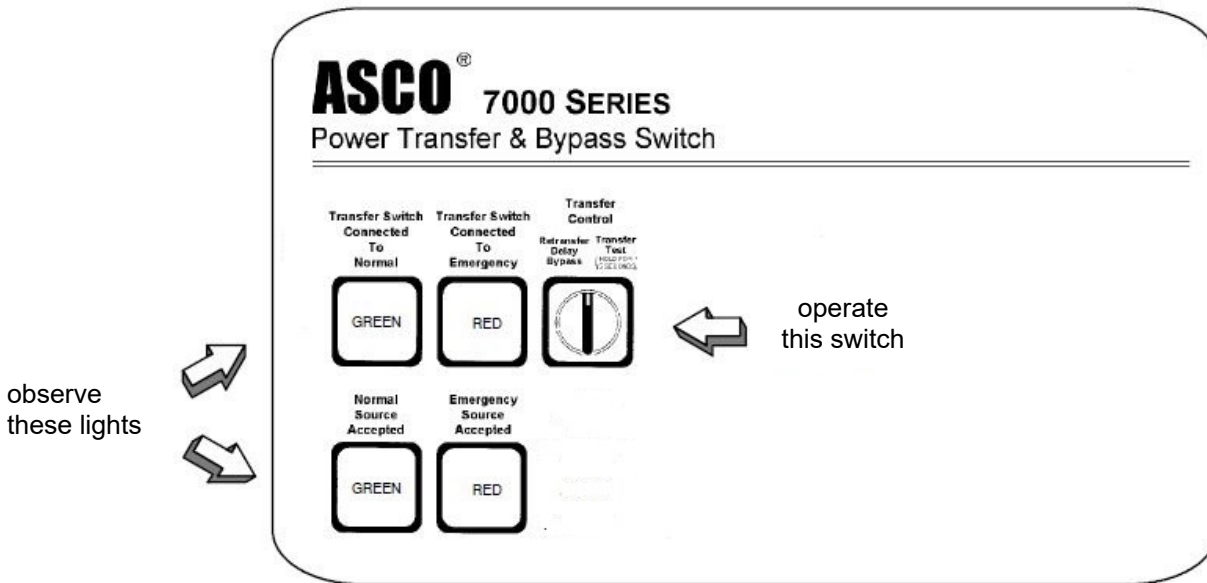

Figure 3. Standard controls and indicators.

2 – Electrical Operation

This procedure checks electrical operation of the ATB.



Be sure to close the enclosure door before proceeding to prevent personal injury in case of electrical system fault.

Transfer Test

The ATS should still be bypassed. Both normal and emergency sources must be available and the emergency source generator (if used) must be capable of being started; put engine starting control in *automatic* position. The *Transfer Switch Connected to Normal* light and the *Normal Source Accepted* light should be on.

1. Turn the **Isolation Handle** counterclockwise to the **TEST** position.

NOTE: The engine generator may be signaled to start while turning the Isolation Handle. If emergency source is available, the ATS may operate to the emergency position. If it does, operate **Retransfer Delay Bypass** switch.

Perform steps 1–5 at right. Observe the status lights. See Figure 3.

■ Black square means light is on.

□ White square means light is off.

2. Turn the **Isolation Handle** clockwise to the **CONN** (connected) position.
3. Turn the **Bypass Handle** clockwise to the **OPEN** position.

This completes the Functional Test of the 7ATB.

1	The <i>Transfer Switch Connected To Normal</i> and <i>Normal Source Accepted</i> lights should be on.	
2	Turn and hold Transfer Control switch clockwise to <i>Transfer Test</i> until the engine starts and runs (within 15 sec.). <i>Emergency Source Accepted</i> light should come on.	
3	Transfer switch will operate to the Emergency position after Feature 2B time delay. The <i>Transfer Switch Connected To Emergency</i> light should come on and <i>Load Connected to Normal</i> light goes off.	
4	Transfer switch will operate back to Normal position after Feature 3A time delay. For immediate retransfer turn Transfer Control counterclockwise to <i>Retransfer Delay Bypass</i> . The <i>Transfer Switch Connected To Normal</i> light should come on; <i>Transfer Switch Connected To Emergency</i> light should go off.	
5	The engine-generator will stop after the Feature 2E time delay (unloaded running engine cooldown). The <i>Emergency Source Accepted</i> light should go off.	

Testing & Service

TRANSFER TEST

Test the Automatic Transfer Switch portion of the 7000 SERIES 7ATB at least once a month. This procedure checks the electrical operation of the Transfer Switch and Controller. Put the engine-generator starting control (at the engine-generator set) in automatic mode.

In the following test the generator will start, the load will be transferred to the Emergency source, then back to the Normal source. An interruption to the load will occur, unless the Transfer Switch contacts are bypassed before the test. See pages 9-12 for bypassing & isolating instructions if no interruption of load is required.



WARNING

Be sure to close the enclosure door before proceeding to prevent personal injury in case of electrical system fault.

Perform the five-step **Electrical Operation – Transfer Test** procedure on page 6.

PREVENTIVE MAINTENANCE

Reasonable care in preventive maintenance will insure high reliability and long life for the 7000 SERIES 7ATB. An annual preventive maintenance program is recommended.

ASCO Power Services, Inc. is ASCO Power Technologies service organization for the United States and Canada. Call 1-800-800-2726 (ASCO) to request a service call and information on preventive maintenance agreements.

Annual Inspection Checklist



DANGER

Hazardous voltage capable of causing shock, burns, or death is used in this switch.

- **Cleaning the 7ATB enclosure**
Brush and vacuum away any excessive dust accumulation. Remove moisture with a clean cloth.
- **Check the transfer switch contacts.**
Bypass, isolate, and withdraw the transfer switch. Then remove the transfer switch interphase barriers and check the condition of the contacts. Replace contacts when pitted or worn excessively. Reinstall the interphase barriers carefully. See page 12.
- **Maintain transfer switch lubrication.**
If switch is subjected to severe dust or abnormal operating conditions, renew factory lubrication on all movements and linkages. Relubricate solenoid operator if TS coil is replaced. Don't use oil; order **lubrication kit 75-100**
- **Check all cable connections** by either thermal measuring or monitoring, or mechanical check. If any connections are loose, retighten them. See pages 3-4

REPLACEMENT PARTS

Replacement parts are available in kit form. When ordering parts provide the Serial No., Bill of Material No. (BOM), and Catalog No. from the transfer switch nameplate. Contact your local ASCO Power Technologies Sales Office or ASCO Power Services, Inc.

In the United States and Canada
call 1 – 800 – 800 – ASCO (2726)

DISCONNECTING THE CONTROLLER

The harness disconnect plugs are furnished for repair purposes only and should not have to be unplugged. If the controller must be isolated, follow these steps.



DANGER

Bypass-Isolation Switch is energized! Do not touch isolation contact fingers; shock, burns, or death could result!

Disconnecting the Plugs

1. Bypass and Isolate the Automatic Transfer Switch.
2. Open the upper enclosure door.
3. Separate the two quick disconnect plugs by squeezing the latches. Do not pull on the harness wires.

Reconnecting the Plugs

1. The ATS should be still bypassed and isolated.
2. The two harness plugs and sockets are keyed. Carefully align the plugs with the sockets and press straight in until the latches click.
3. Close the enclosure doors.
4. Follow *Return to Service* instructions on page 13.

MANUAL LOAD TRANSFER

This procedure manually transfers load to other source if the Transfer Switch or Control Panel are out of service.

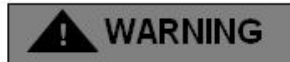

WARNING

Close enclosure doors to prevent personal injury in case of electrical system fault.

1. Bypass the connected ATB source. Turn Bypass Handle to EMERGENCY or NORMAL (see page 10).
2. Isolate to Test. Turn the Isolation Handle to TEST position (see page 11).
3. Turn the Bypass Handle to OPEN, then to the other source (see page 9). The load will be interrupted.
4. Turn the Isolation Handle clockwise to the CONN [connected] position (see page 12).

TROUBLE-SHOOTING

Note any optional accessories that may be furnished on the 7ATB and review their operation. Refer to any separate drawings and/or instructions that may be packed with the 7ATB. See Table B.



Hazardous voltage capable of causing shock, burns, or death is used in this switch. Do not touch the power or load terminals of the bypass switch or transfer switch!

Table B. Trouble-Shooting Checks.

PROBLEM	CHECK IN NUMERICAL SEQUENCE		
	1 OPERATION	2 GEN-SET	3 VOLTAGE
Engine-generator set does not start when the Transfer Control switch is turned and held in <i>Transfer Test</i> position or when normal source fails.	Hold <i>Transfer Test</i> switch 15 seconds or the outage must be long enough to allow for Feature 1C time delay plus engine cranking and starting time.	Starting control must be in the automatic position. Batteries must be charged and connected. Check wiring to engine starting contacts.	-
Transfer switch does not transfer the load to the emergency source after the engine-generator set starts.	Wait for Feature 2B time delay to time out (if used)	Generator output circuit breaker must be closed. Generator frequency must be at least 95% of nominal (57 Hz for a 60 Hz system.) *	Voltmeter should read at least 90% of nominal phase to phase voltage between transfer switch terminals EA & EC (or EL1 & EL2 for 2 pole). *
Transfer switch does not transfer the load to normal source when normal returns or when the Transfer Control switch is released.	Wait for Feature 3A time delay to time out (if used)	-	Voltmeter should read at least 90% of nominal phase to phase voltage between transfer switch terminals NB & NC, NC & NA, and NA & NB (or NL1 and NL2 for 2 pole).
Engine-generator-set does not stop after load retransfer to the normal source.	Wait for Feature 2E time delay to time out (if used)	Starting control must be in the automatic position.	-

* These are factory settings. Refer to the **Group 5 Controller User's Guide**.

If the problem is isolated to circuits on the controller or the transfer switch, call your local ASCO Power Technologies sales office or ASCO Power Services, Inc.: in the United States or Canada, call 1-800-800-2726. Furnish the Serial No., Catalog No., and Bill of Material (BOM) No. from the transfer switch nameplate.

MAINTENANCE HANDLE



Bypass and isolate the Transfer Switch before using the maintenance handle! See pages 9-12. Remove the maintenance handle after using it; store it inside.

1. Bypass, isolate, and withdraw the transfer switch (pages 9-12). Then locate and remove the maintenance handle from the clip (inside lower left side). Insert the handle into the hole in the molded hub on the left side of the operator of the transfer switch. See Figure 4 and Table C.

Table C. Maintenance handle positions

ATS Position	Handle	Indicators
Normal		E = O upper contacts open N = C lower contacts closed
Emergency		E = C upper contacts closed N = O lower contacts open

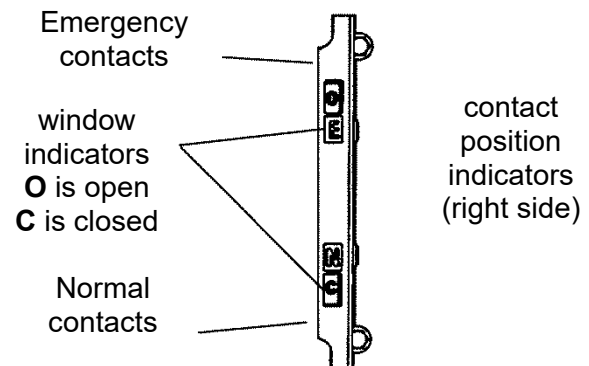
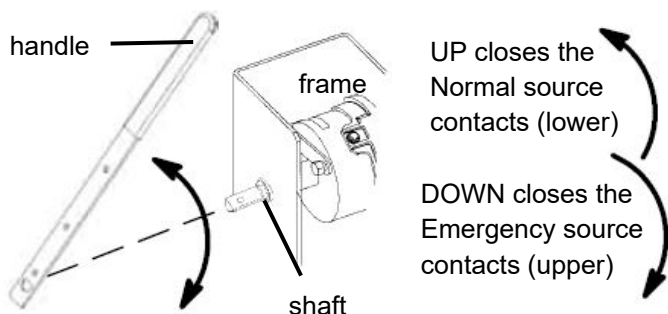

Figure 4. Maintenance handle operation and contact position indicators.

Bypassing & Isolating

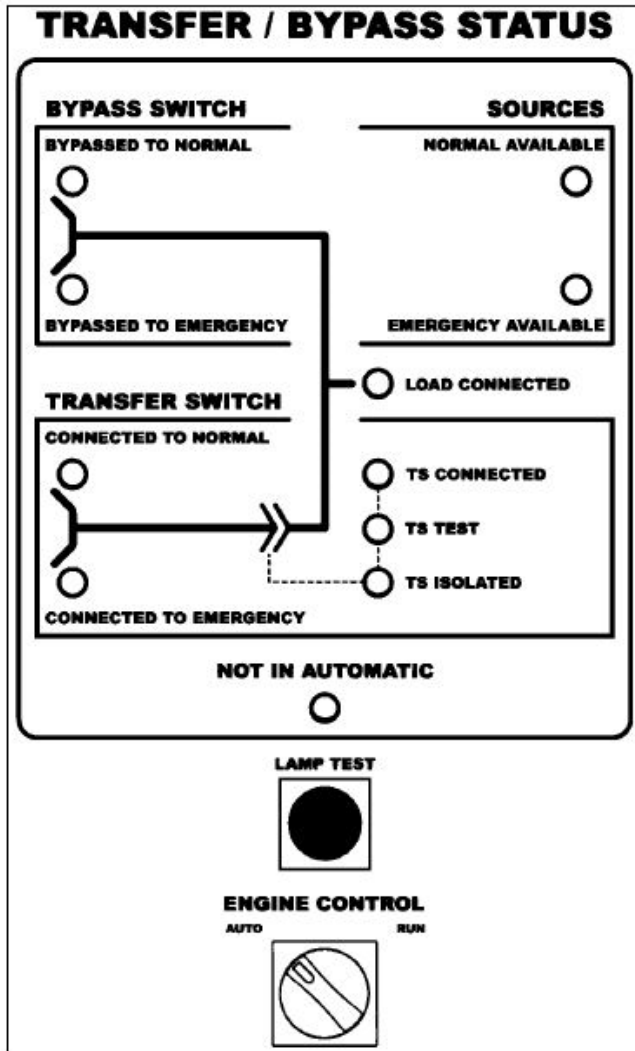

Figure 5. Status lights and Engine Control.

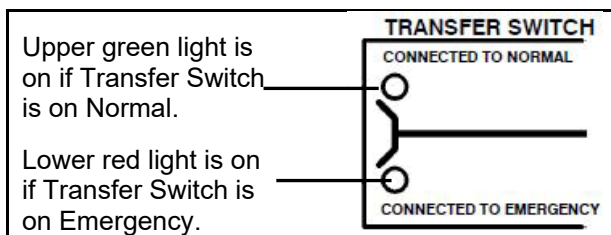

Figure 6. Status lights for Transfer Switch main contact position.

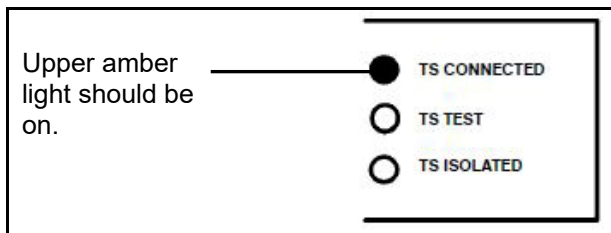

Figure 7. Status lights for Transfer Switch isolation contact position.

BYPASSING THE ATS*

This procedure explains how to Bypass the closed transfer switch contacts. Bypassing is required before the Transfer Switch can be tested or isolated. The Bypass Switch Handle must be in the *OPEN* position (green window indicator) and the Isolation Handle must be in the *CONN* [connected] position (window indicator). The *TS Connected* light must be on. See Figures 5, 6 and 7.

CAUTION

You can only bypass to the same source that the Transfer Switch is connected. Solenoid interlock prevents incorrect operation.

Observe which *Transfer Switch Connected To* light is on (*Normal* or *Emergency*) on the door. This is the position of the transfer switch (see Figure 6).

Follow the directions on next page to Bypass to the same source as connected to transfer switch (select Normal or Emergency).

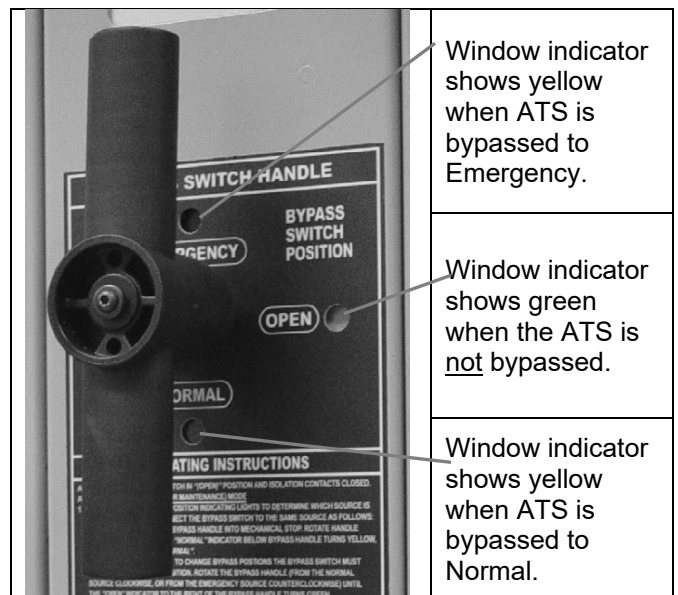

Figure 8. Bypass Handle and three position window indicators.

NOTE: The 7ATB contains mechanical (window) indicators for the bypass switch and transfer switch positions in addition to the LED status lights.

Allowable Positions of the Bypass Switch in relation to Positions of the Transfer Switch (with Isolation Handle in the *Conn* [connected] position and *TS Connected* light on)

Transfer Switch	Bypass Switch can be in either	
If Transfer Switch is in Normal position	Open or	Normal
If Transfer Switch is in Emergency position.	Open or	Emergency

Bypassing & Isolating

To Bypass Normal Source*

(Load connected to Normal Source)

The *Transfer Switch Connected To Normal* light is on and *Transfer Switch Connected To Emergency* light is off.

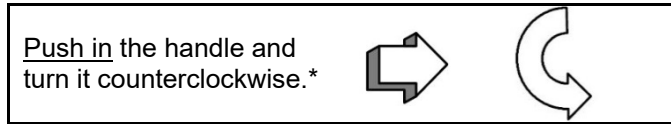

Push in* the Bypass Handle all the way, then turn it counterclockwise until *Bypass Switch Position* shows closed on NORMAL (yellow window indicator). The green light *Bypassed to Normal* will come on and the amber light *Not In Automatic* will flash.

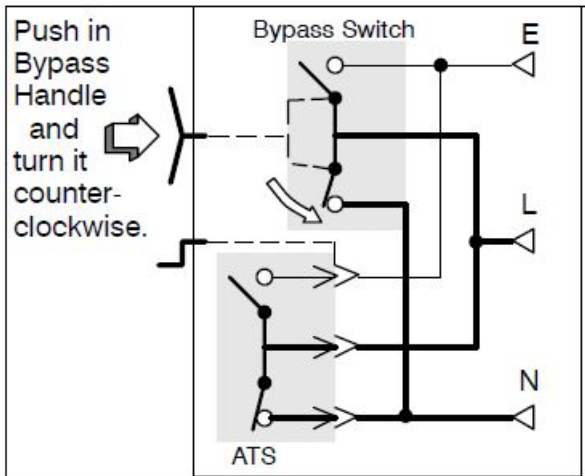

Figure 9. Bypass to Normal diagram.

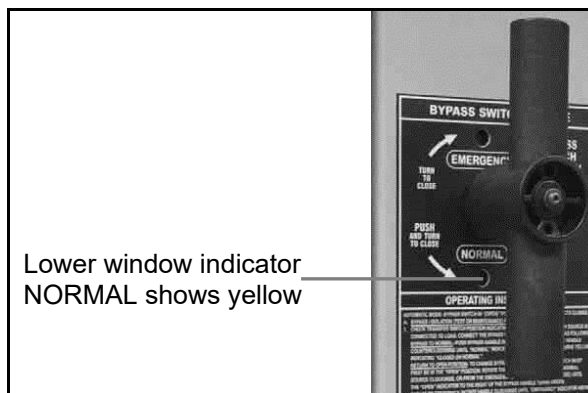
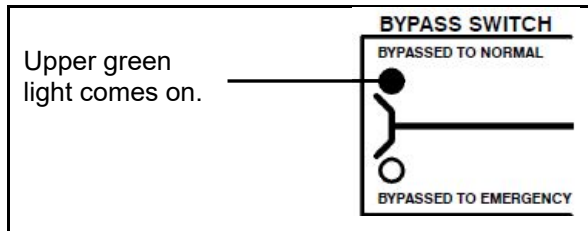
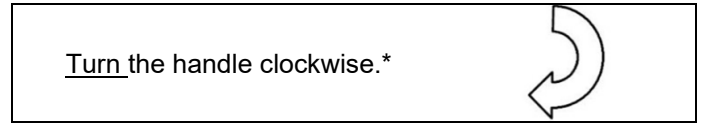

Figure 10. Status light and window indicator for Bypassed to Normal Source.

To Bypass Emergency Source*

(Load connected to Emergency Source)

The *Transfer Switch Connected To Emergency* light is on and *Transfer Switch Connected To Normal* light is off.



Turn* the Bypass Handle clockwise until *Bypass Switch Position* shows closed on EMERGENCY (yellow window indicator). The red light *Bypassed to Emergency* will come on and the amber light *Not In Automatic* will flash.

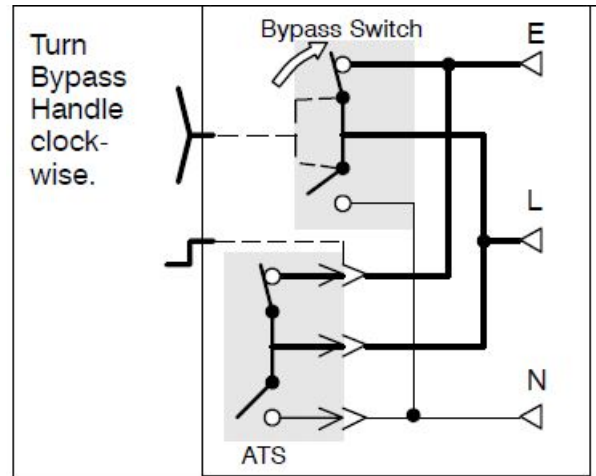

Figure 11. Bypass to Emergency diagram.

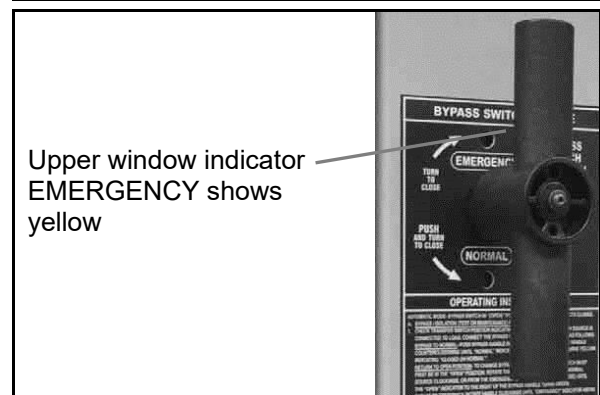
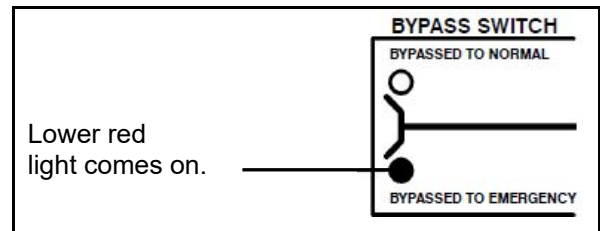

Figure 12. Status light and window indicator for Bypassed to Emergency Source.

The automatic transfer switch can now be put in the *TEST* or *OPEN* position. See **ISOLATING** on page 11.

* **NOTE:** When Accessory 40*B (reversed Normal & Emergency connections) is specified, the handle operation is reversed. Follow instructions on the door.

Bypassing & Isolating

ISOLATING THE ATS

Isolating is required before any service work can be performed on the automatic transfer switch (ATS). Refer to Figures 13, 14, 15 and 16.

1. Bypass the closed automatic transfer switch contacts. See **BYPASSING** on pages 9 and 10.
2. Turn the Isolation Handle counterclockwise (approx. 8 turns) until window shows *TEST*. The *TS Test* amber light should come on. The ATS can be tested now without load interruption (see page 7).

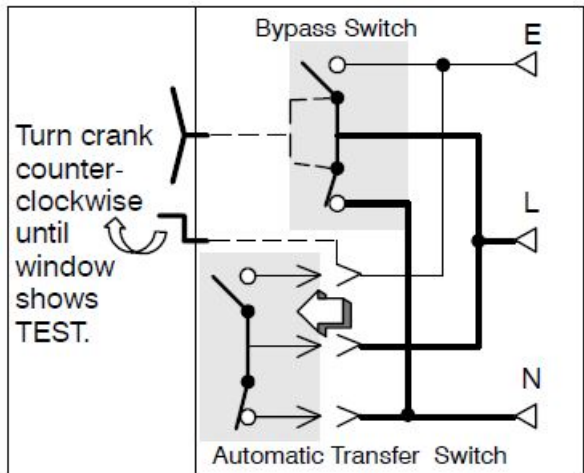
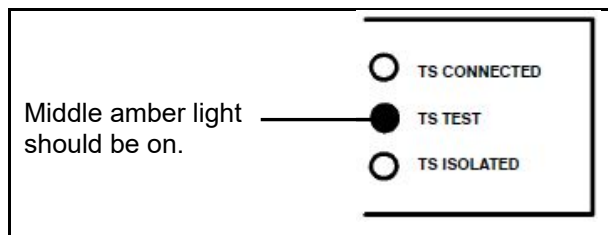

Figure 13. *CONNECTED* to *TEST* position.



NOTE: In the *TEST* position the transfer switch solenoid operator circuit is energized through secondary disconnects.

! DANGER

Hazardous voltage capable of causing electrical shock, burns, or death; do not touch any control circuit terminals.

3. Continue turning Isolation Handle counterclockwise (approx. 6 turns) until the window shows *ISOLATE*. The *TS Isolated* amber light should come on.

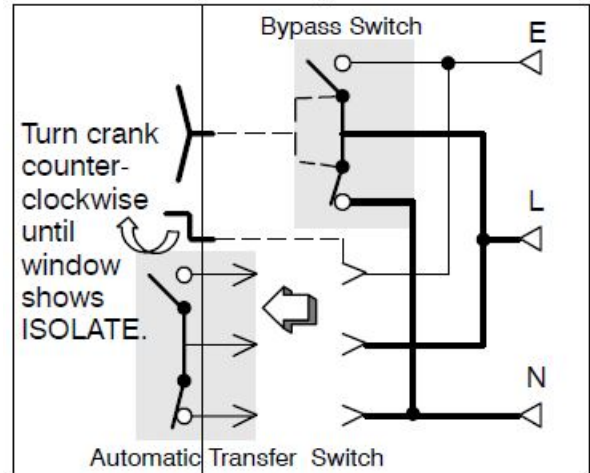

Figure 15. *TEST* to *ISOLATE* position.

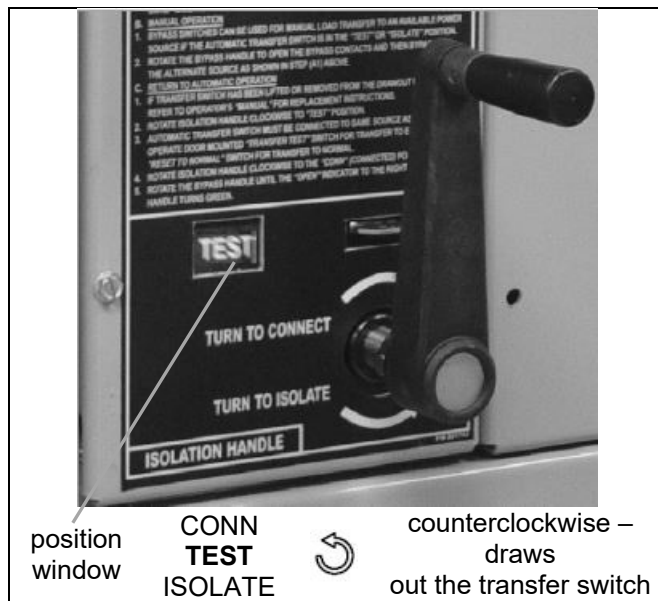
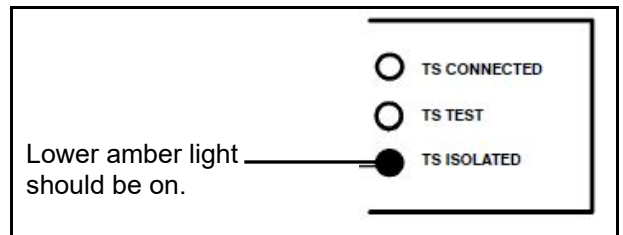

Figure 14. Isolation Handle turned to *TEST*.

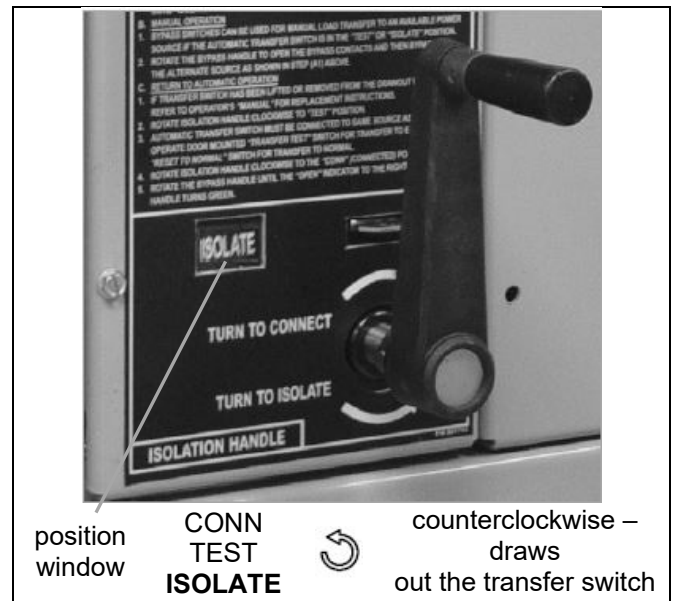

Figure 16. Isolation Handle turned to *ISOLATE*

Bypassing & Isolating

NOTE: Provisions are provided for locking the transfer switch in the isolate position. When the switch is in the isolate position, pull the lockout tab (Figure 17) out to expose the hole in the tab and insert a padlock (padlock not provided). This prevents the transfer switch from returning to service until the padlock is removed.

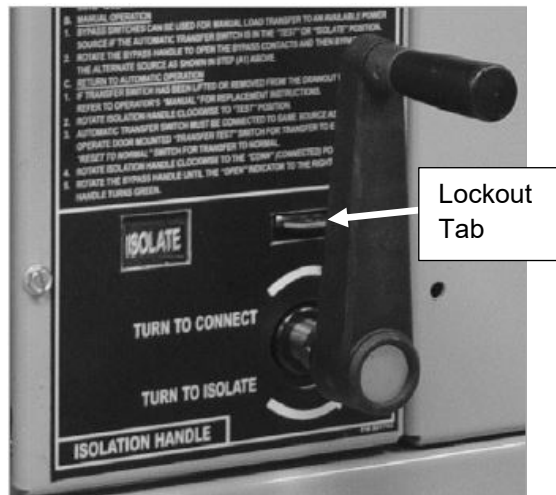

Figure 17. Lockout Tab location

- Open the lower enclosure door. Pull out both left and right side rails then use the two tab handles to roll out the transfer switch. It can be safely inspected in this position. The transfer switch can also be removed for easier maintenance operations. See Figure 18.

! DANGER

Hazardous voltage capable of causing electrical shock, burns, or death; do not touch any control circuit terminals

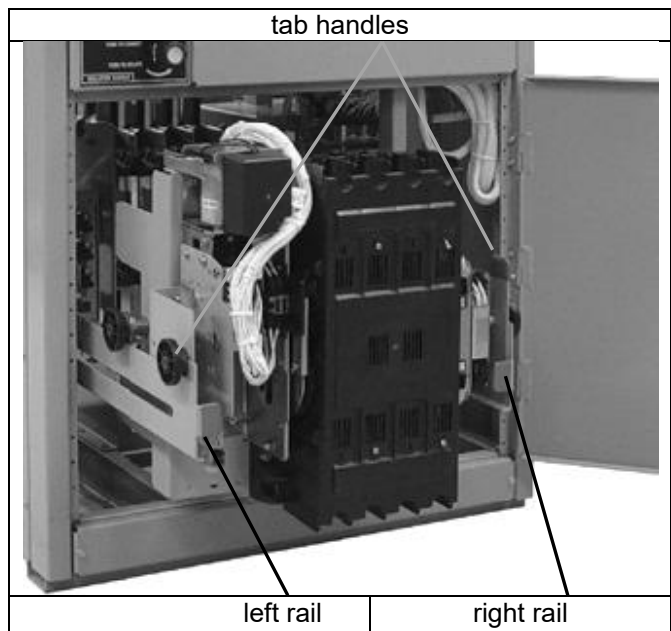

Figure 18 .Transfer switch isolated and pulled out for inspection.

See page 9 for maintenance handle use. A lifting yoke 812053 is available to facilitate lifting by using an overhead crane or similar equipment. See **WARNING**.

! WARNING

The Transfer Switch weighs about 120 lbs. depending upon the number of poles. Use lifting device 812053 or other device capable of lifting this weight to avoid personal injury or equipment damage. Two persons are recommended.

Contact Inspection

Contact condition should be checked annually. Discoloration is normal. Do not file contacts because it wastes material. Instead use light emery paper to clean up the contact surfaces. The non-replaceable main contacts are designed to last the life of the transfer switch.

Bypassing & Isolating



To prevent the possibility of fatal electrical shocks and burns, bypass, isolate, and withdraw the transfer switch before working on it. Top Bypass Switch and rear stabs are still energized! Do not touch these parts; shock, burns, or death could result!

1. **Bypass, isolate, and withdraw transfer switch.** (pages 9 thru 12)
 Bypassing, isolating and withdrawing the transfer switch located in the lower part of the enclosure will remove power from the lower transfer switch. Use a voltmeter to verify that no electrical power is present at the transfer switch terminals.
2. **Use the maintenance handle** (page 8).
 Open the contacts that will be inspected by using the detachable maintenance handle.
3. **Remove the barrier** (Figure 19).
 Use a phillips screwdriver to loosen (ccw) four or six captive round-head screws holding the barrier to the arc chutes. Then pull the barrier straight outward to remove it.
4. **Reinstall the barrier.**
 Install the barrier over the arc chutes. Use a phillips screwdriver to tighten (cw) the four or six round-head screws to secure the barrier to the arc chute insulator nuts. See Figure 19.

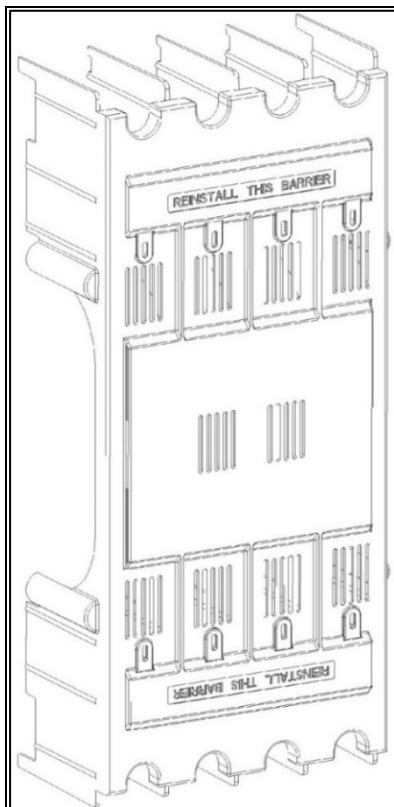

Figure 19. Barrier removal

RETURN TO SERVICE

This procedure explains how to return the automatic transfer switch (ATS) to service after inspection and maintenance. Observe the *Bypass Switch Position* indicator and lights).

1. Use the two tab handles to roll the transfer switch into the enclosure (isolation contacts facing inward) until the crank bearings stop against the draw-in plates. Then push in both side rails and close the enclosure door.

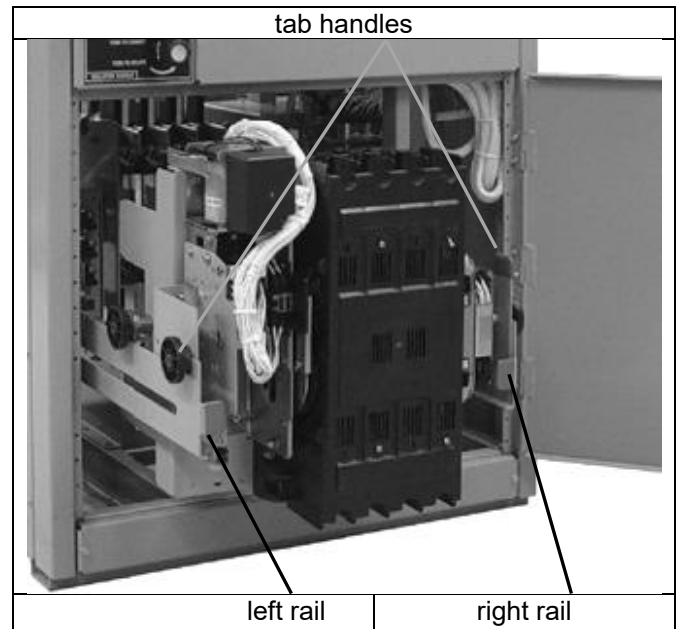

Figure 20. Transfer switch isolated and pulled out for inspection.



Close the enclosure door to prevent personal injury in case of electrical system fault.

2. Turn Isolation Handle clockwise (approx. 6 turns) until the window shows *TEST* and *TS TEST* light comes on.

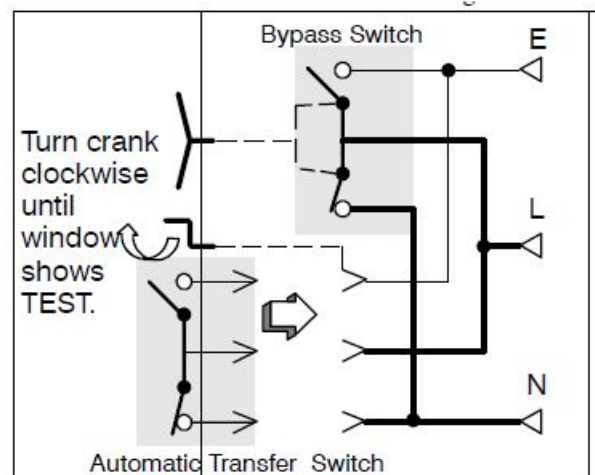

Figure 21. ISOLATE to TEST position.

Bypassing & Isolating

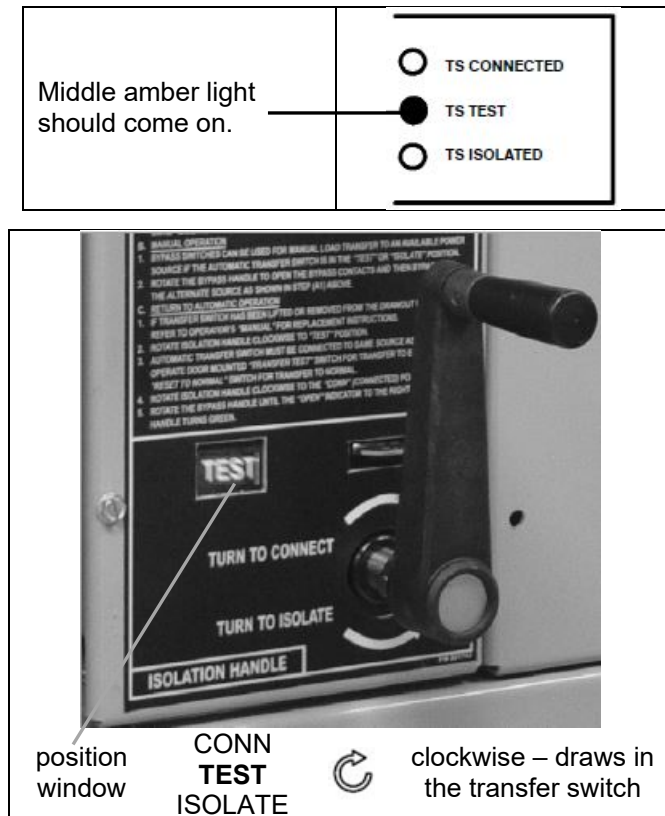

Figure 22 Isolation Handle turned to TEST

- The ATS can be tested now without load interruption (see page 7).

CAUTION

Solenoid interlock prevents you from closing the isolation contacts until the ATS is in the same position as the Bypass Switch.

- Observe which *Bypass Switch Position* window indicator is yellow (*NORMAL* or *EMERGENCY*) at the Bypass Switch Handle. This indicates the source connected to the load.
- Observe which *Transfer Switch Connected To* light is on (*Normal* or *Emergency*) on the door. This is the position of the Transfer Switch. If it is not in the same position as the Bypass Handle change the position of the Transfer Switch as follows:

To change the position of transfer switch

Operate to NORMAL	Operate to EMERGENCY
Turn Transfer Control switch to <i>Retransfer Delay Bypass</i> .	Turn Transfer Control switch to <i>Transfer Test</i> (hold 15 seconds).*
<i>Connected To Normal</i> light should come on.	<i>Connected To Emergency</i> light should come on.

* If Feature 2B time delay is used, there will be a delay before transfer to Emergency

NOTE: With Normal available, the automatic transfer switch will not stay in the emergency position unless Feature 3A time delay is used (at least 30 seconds).

WARNING

Do not close the isolation contacts unless the Transfer Switch (ATS) and Bypass Switch are in the same position!

- When the transfer switch is in the same position as the Bypass Switch handle, continue turning the Isolation Handle clockwise (about 8 turns) until the window shows *CONN* (connected).

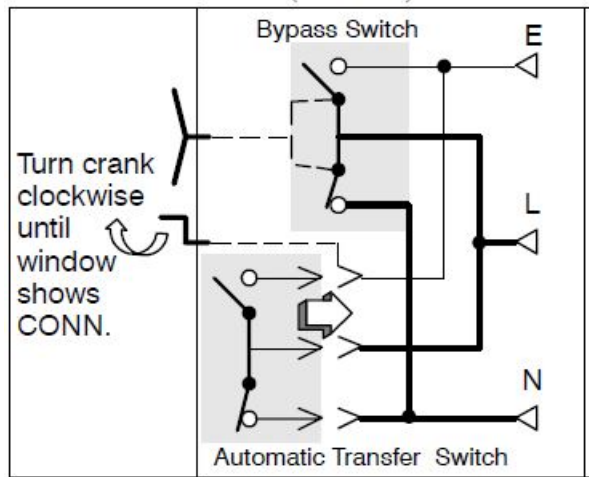

Figure 23. TEST to CONN (connected) position.

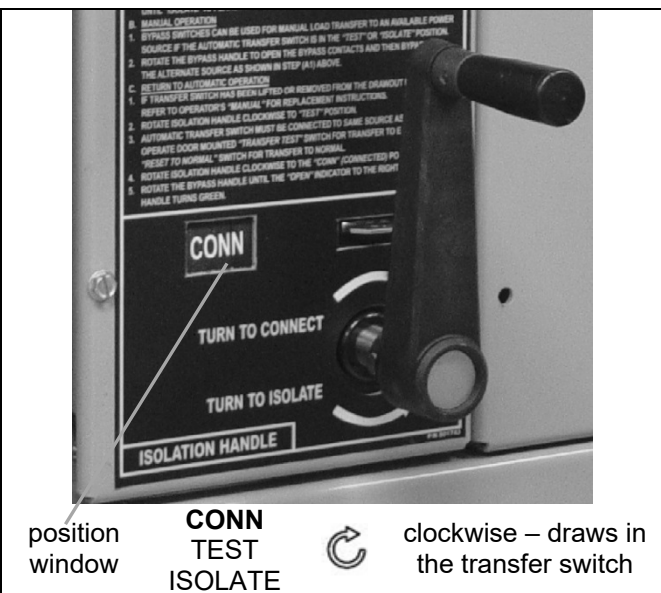
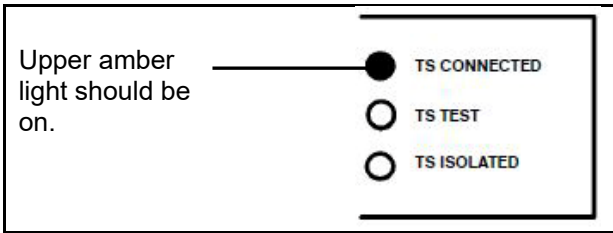

Figure 24. Isolation Handle turned to CONN

Bypassing & Isolating

RETURN TO SERVICE continued*

This procedure explains how to return the Bypass Switch Handle to the OPEN position. The Bypass Handle must be in the *CLOSED* position (yellow indicator on *NORMAL* or *EMERGENCY*) and the Isolation Handle must be in the *CONN* position (window). See Figures 25, 26 and 27.



You can only bypass to the same source that the ATS is connected. Solenoid interlock prevents incorrect operation.

1. Observe which Bypass Switch Position indicator is yellow (*NORMAL* or *EMERGENCY*) at the Bypass Switch Handle. This indicates the source connected to the load.
2. Un-Bypass to same source as the Bypass Switch Position as follows (select Normal or Emergency).

To Un-Bypass Normal Source* (Load connected to Normal Source)

The *Transfer Switch Connected To Normal* light is on and *Transfer Switch Connected To Emergency* light is off.

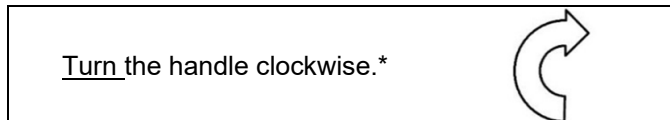

Turn* the Bypass Handle clockwise until the *Bypass Switch Position* shows OPEN (green window indicator). The *Bypassed to Normal* light should go off and the *Not In Automatic* light should go off.

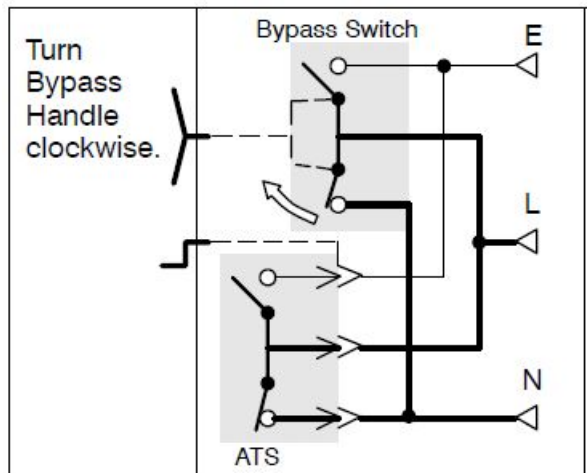

Figure 26 Un-Bypass Normal diagram.

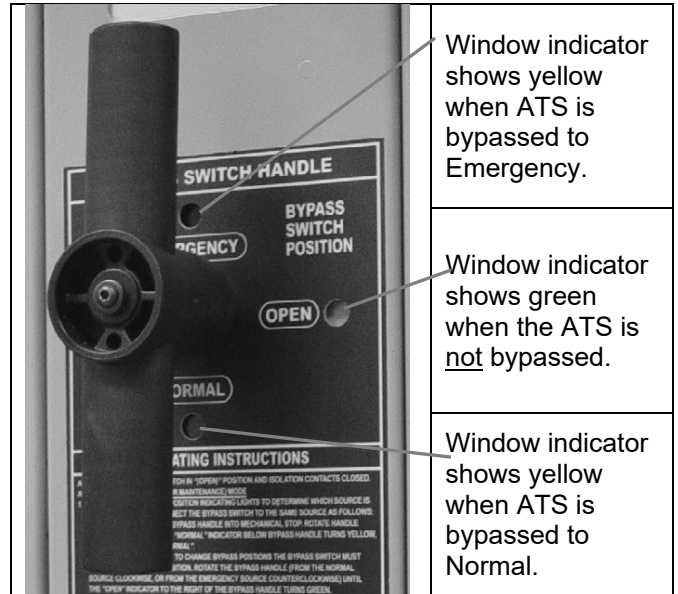
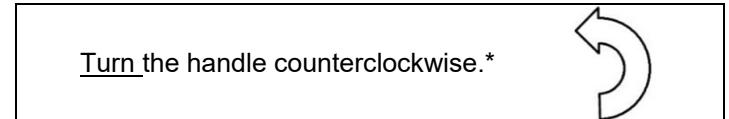

Figure 25. Bypass Handle and window indicators.

To Un-Bypass Emergency Source* (Load connected to Emergency Source)

The *Transfer Switch Connected To Emergency* light is on and *Transfer Switch Connected To Normal* light is off.



Turn* the Bypass Handle counterclockwise until the *Bypass Switch Position* shows OPEN (green window indicator). The *Bypassed to Emergency* light should go off and the *Not In Automatic* light should go off.

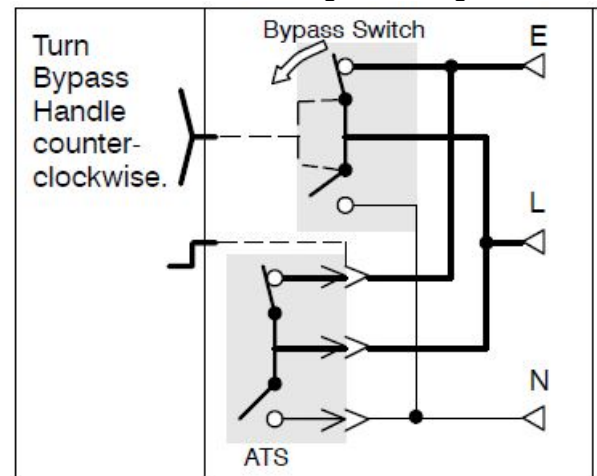

Figure 27. Un-Bypass Emergency diagram.

The Automatic Transfer & Bypass-Isolation Switch should be left in this position.

*** NOTE:** When Accessory 40*B (reversed Normal & Emergency connections) is specified, the handle push-pull operation is reversed. Follow instructions on the door.

INDEX

A

auxiliary circuits, 4

B

barriers, interphase, 7, 12

bypassing the ATS, 9

C

catalog number, 3

cleaning, 7

conductors

power, 3

contact inspection, 12

controller

disconnecting, 7

see *Controller User's Guide*

E

electrical operation, 6

Emergency Source Accepted light, 5, 6

engine starting contacts, 4, 8

F

Foundation, 3

functional test, 4, 5, 6

frequency, generator, 8

H

harness, 4, 7

disconnect plugs, 7

help

customercare@ascopower.com

800-800-ASCO (2726)

I

inspection, 7, 12, 13

installation, 3, 4, 5, 6

interphase barriers, 7

isolating the ATS, 11

L

lifting device, transfer switch, 12

lights, 5, 6, 9, 13

load connected to emergency, 10, 15

load connected to normal, 6, 10, 15

lubrication, 7

M

maintenance, preventive, 7

maintenance handle, 8

warning, 8

manual load transfer, 7

warning, 7

N

nameplate, 3

Normal Source Accepted light, 5, 6

O

Operation

electrical, 6

manual, 7

warning, 7

P

parts, 7

phase rotation, 5

preventive maintenance, 7

problem, 8

R

rating label, 1

replacement parts, 7

return to service, 13, 14, 15

S

service

ASCO Power Services, Inc., 7

settings

see *Controller User's Guide*

T

test, functional, 4, 5, 6

testing power cables, 3

time delays,

see *Controller's User's Guide*

Transfer Control switch, 6, 8, 13

Retransfer Delay Bypass, 6, 13

Transfer Test, 6

Transfer Switch Connected To
Emergency light, 6, 10, 15

Transfer Switch Connected To
Normal light, 6, 10, 15

transfer test, (testing & service) 7, 8

transfer to emergency, 13

troubleshooting, 8

V

voltage checks, 5

voltage, pickup and dropout settings

see *Controller User's Guide*