

# ASCO 7000 SERIES Automatic Transfer Switches

## 7ATS, 7ACTS, 7ADTS

### G, Q, S, & U design

## Installation Manual

381333-414 A  
9/2016



DANGER is used in this manual to warn of a hazard situation which, if not avoided, will result in death or serious injury.



WARNING is used in this manual to warn of a hazardous situation which, if not avoided, could result death or serious injury.



CAUTION is used in this manual to warn of a hazardous situation which, if not avoided, could result in minor or moderate injury.

### Rating Label

Each transfer switch contains a rating label to define the loads and fault circuit withstand/closing ratings. Refer to the label on the transfer switch for specific values.



Do not exceed the values on the rating label. Exceeding the rating can cause person injury or serious equipment damage.

**An experienced licensed electrician must install the transfer switch.**

### Catalog Number Identification

Typical 7000 Series catalog no. for G-design solid neutral, 3 pole, 4000 A, 480 V, ATS in Type 1 enclosure:

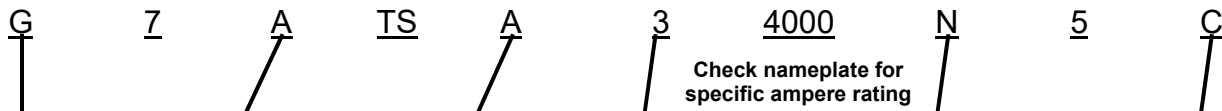

Design	Transition Type	Neutral	Poles	Voltage			Enclosure
G	A open	A-solid	2-single	C 208	H 380	N 480	C- Type 1
Q	AC closed	B-switched	3-three	D 220	J 400	P 550	F- Type 3R
S	AD delayed	C-overlapping*		E 230	K 415	Q 575	- Type 3RX
U		blank- none		F 240	L 440	R 600	
				G 277	M 460		

\*Overlapping neutral not available for Q, S, & U-designs

Refer to the outline and wiring drawings provided with the ATS for all installation and connection details and accessories.

Refer to **User's Guide 381333-126** for the Group 5 Controller status display messages, time delays, pickup and dropout settings, and adjustments

## Table of Contents

- Rating Label..... 1
- Catalog Number Identification ..... 2
- Installation ..... 1
  - Supporting Foundation ..... 1
  - Mounting ..... 2
  - Line Connections ..... 2
  - Testing Power Conductors ..... 2
  - Connecting Power Cables ..... 2
  - Bus Connections ..... 3
  - Harnesses ..... 3
  - Auxiliary Circuits ..... 3
  - Controller Ground ..... 3
  - Engine Starting Contacts ..... 3
  - Functional Test ..... 3
  - Functional Test– Manual Operation Test ..... 3
  - Functional Test– Voltage Checks ..... 5
  - Functional Test - Electrical Operation ..... 6
- Testing & Service ..... 7
  - Transfer Test ..... 7
  - Preventive Maintenance ..... 7
  - Replacement Parts ..... 7
  - Manual Load Transfer ..... 7
  - Trouble-Shooting ..... 8

# Installation

These transfer switches are factory wired and tested. Installation requires mounting, connecting service cables, and connecting engine start and auxiliary control circuits (if required.).

## Supporting Foundation

The supporting foundation for the enclosure must be level and straight. Refer to the applicable enclosure outline drawing included with the transfer switch for all mounting details including door opening space.

If bottom cable entry is used, the foundation must be prepared so that the conduit stubs are located correctly. Refer to the enclosure outline drawing for specified area and location. Provide cable bending space and 1 inch minimum clearance to live metal parts. When a concrete floor is poured, use interlocking conduit spacer caps or a wood or metal template to maintain proper conduit alignment.

## Mounting

Refer to the outline and mounting diagram and mount the transfer switch according to details and instructions shown on the diagram. Mount it vertically to a rigid supporting structure. Level all mounting points by using flat washers behind the holes to avoid distortion of the transfer switch.

**NOTICE**

Protect the transfer switch from construction grit and metal chips to prevent malfunction or shortened life of the transfer switch.

## Line Connections

Refer to the wiring diagram provided with the transfer switch. All wiring must be made in accordance with the National Electrical Code and local codes.

**! DANGER**

De-energize the conductors before making any line or auxiliary circuit connections. Be sure that the Normal and Emergency line connections are in proper phase rotation. Place the engine generator starting control in the OFF position. Make sure engine generator is not in operation.

## Testing Power Conductors

Do not connect the power conductors to the transfer switch until they are tested. Installing power cables in conduit, cable troughs, and ceiling-suspended hangers often requires considerable force. The pulling of cables can damage insulation and stretch or break the conductor's strands. For this reason, after the cables are pulled into position, and before they are connected, they should be tested to verify that they are not defective or have been damaged during installation

## Connecting Power Cables

After the power cables have been tested, connect them to the appropriate terminal lugs on the transfer switch as shown on the wiring diagram provided with the transfer switch. Make sure that the lugs provided are

suitable for use with the cables being installed. Standard terminal lugs are solderless screw type and will accept the wire sizes listed on the drawings provided with the transfer switch. Be careful when stripping insulation from the cables, avoid nicking or ringing the conductor. Remove surface oxides from cables by cleaning with a wire brush. When aluminum cable is used, apply joint compound to conductors. Tighten cable lugs to the torque specified on rating label.

## Harnesses

The transfer switch is connected to the left side of the controller by a plug-in harness (two plugs).

## Bus Connections

If bus connection is used, use SAE grade 5 hardware to connect bus to appropriate terminal plates on the transfer switch. Wipe off bus surfaces before they are joined. If bus is very dirty, gently clean surfaces with a non-flammable solvent. Avoid touching cleaned surfaces. Tighten the bolted joints according to the size of the bolts that are used

## Auxiliary Circuits

Connect auxiliary circuit wires to appropriate terminals on the transfer switch as shown on the wiring diagram.

## Controller Ground

A grounding wire must be connected to the controller's lower left mounting stud. Because the controller is mounted on the enclosure door, a conductive strap must be used between the enclosure and the door. This connection provides proper grounding which does not rely upon the door hinges.

## Engine Starting Contacts

The engine control contact connections (if used) are located on the transfer switch. Connect signal wires to appropriate terminals as specified in Table A and shown in Figure 1.

Table A. Engine Start Connections.

When normal source fails	Terminals on transfer switch
contact closes	TB1 and TB2
contact opens	TB1 and TB3

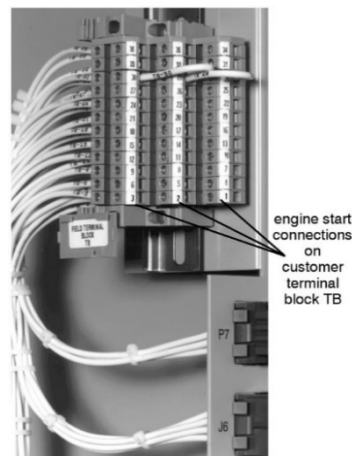

Figure 1. Engine start and auxiliary circuit terminal block.

# Functional Test

The functional test consists of three checks: manual operation, voltage checks, and electrical operation.

**NOTICE**

Do these checks in the order presented to avoid damaging the transfer switch.

## 1 – Manual Operation

A maintenance handle is provided on the transfer switch for maintenance purposes only. Manual operation of the transfer switch should be checked before it is energized (operated electrically).

**WARNING**

Do not manually operate the transfer switch until both power sources are disconnected: open both circuit breakers.

1. After deenergizing both power sources, open the enclosure door. Locate and remove the maintenance handle from the clip on the left side of the transfer switch. See Figures 3, 4, and 5. See Figure 2 for the contact position indicators.
2. Install the handle into the hole in the molded hub. Move the handle up or down as shown to manually operate the transfer switch. It should operate smoothly without any binding. If it does not, check for shipping damage or construction debris.
3. 7ACTS and 7ADTS have two contact shaft hubs. See Figure 5.
4. Return the transfer switch to the Normal position.

**Note:** If Normal and Emergency connections are reversed this operation is also reversed.

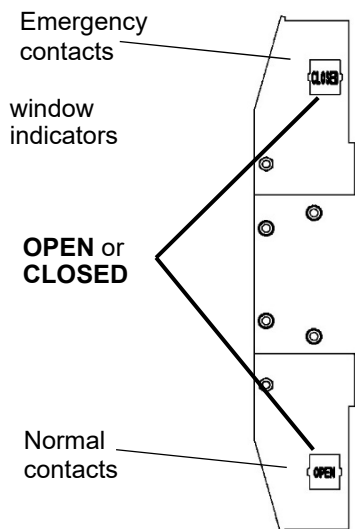

Figure 2. Main contact position indicators on right side.

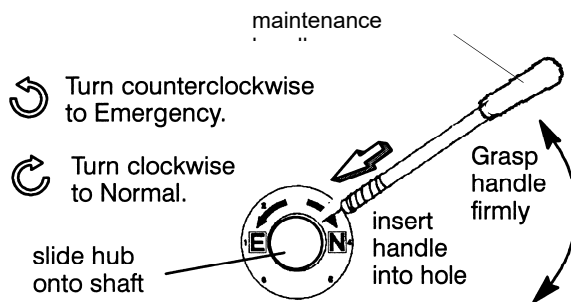

Figure 3. Maintenance handle on 7ATS.

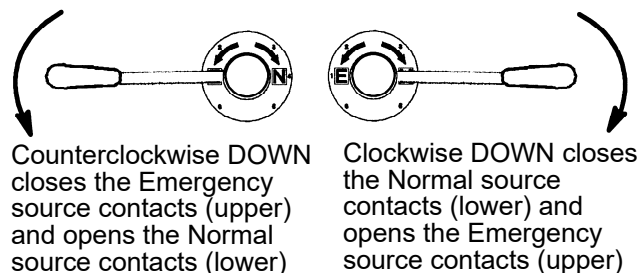

Figure 4. Maintenance handle operation on 7ATS.

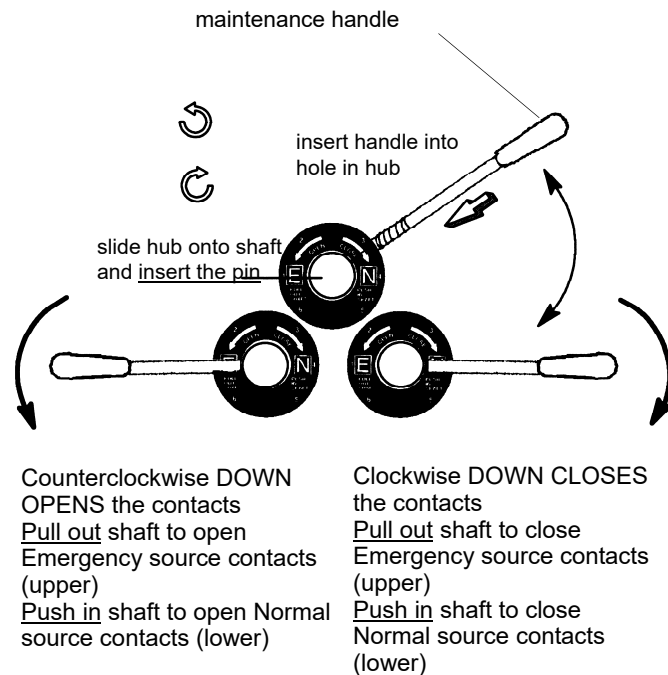

Figure 5. Maintenance handle on 7ACTS & 7ADTS.

**NOTICE**

Refer to User's Guide 381333-126 for the Group 5 Controller. Section 3 shows how to display the Status of the ATS and the voltage and frequency of each source. Section 2 shows the settings.

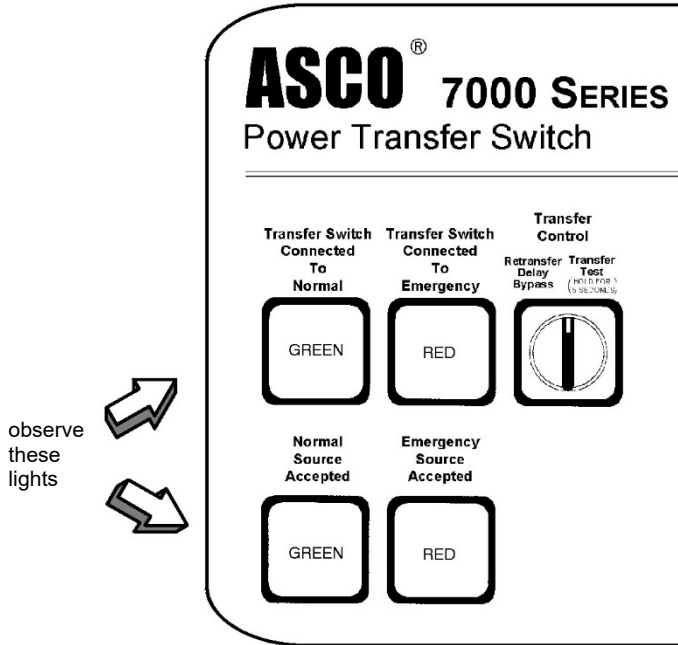

Figure 6. Standard controls and indicators.

**2 – Voltage Checks**

First check the nameplate on the transfer switch; rated voltage must be the same as normal and emergency line voltages.



Use extreme caution when using a meter to measure voltages in the following steps. Do not touch power terminals; shock, burns, or death could result!

Perform steps 1 through 6 at the right. Observe the indicator lights. See Figure 6.

- Black square means the light is on.
- White square means the light is off.

\* If necessary, adjust the voltage regulator on the generator according to the manufacturer's recommendations. The transfer switch will respond only to the rated voltage specified on the transfer switch nameplate.

1	Close the normal source circuit breaker. The <i>Transfer Switch Connected To Normal</i> and the <i>Normal Source Accepted</i> lights should come on.	
2	Use an accurate voltmeter to check phase to phase and phase to neutral voltages present at the transfer switch normal source terminals.	
3	Close the emergency source circuit breaker. (Start generator, if necessary.) The <i>Transfer Switch Connected To Normal</i> and the <i>Emergency Source Accepted</i> lights should come on.	
4	Use an accurate voltmeter to check phase to phase and phase to neutral voltages present at the transfer switch emergency source terminals.*	
5	Use a phase rotation meter to check phase rotation of emergency source; it must be the <u>same</u> at the normal source.	
6	Shut down the engine-generator, if applicable. The <i>Emergency Source Accepted</i> light should go off. Then put the starting control selector switch (on the generator set) in the <i>automatic</i> position. Close enclosure door.	

Continue to **3 – Electrical Operation** on the next page.

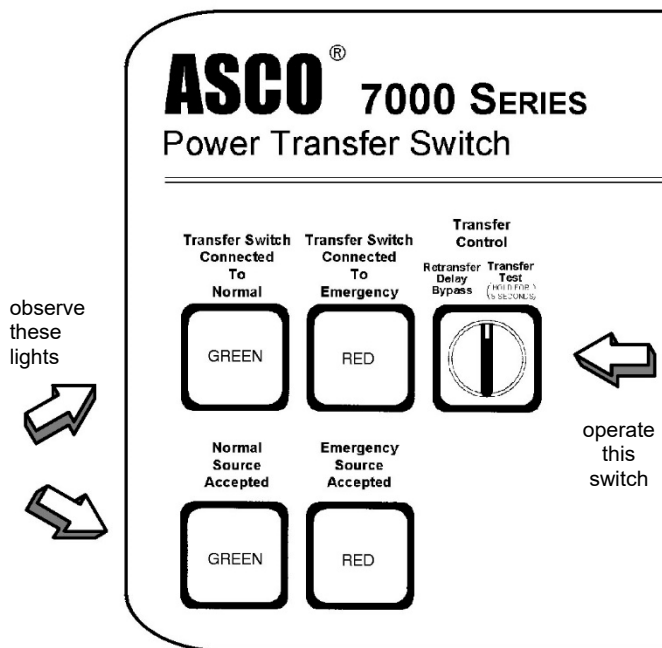

Figure 7. Transfer control and indicator lights.

### 3 – Electrical Operation

This procedure will check the electrical operation of the transfer switch.



Close the transfer switch enclosure door and tighten the screws before you test electrical operation.

Perform steps 1 through 5 at the right. Observe the status lights. See Figures 7, 8, 9.

- Black square means light is on.
- White square means light is off.

Also see User's Guide 381333-126 for inphase transfer and time delay settings in the controller.

#### 7ACTS

The load is transferred via overlap (closed) transition. Transfer switch CE closes and then transfer switch CN opens. The operation is reversed for retransfer back to normal.

If you do **not** want closed-transition transfer, press the **Closed Transition Bypass** button (Figure 8) while the controller display shows *Waiting for In-Sync*. This action causes open-transition (momentary load interruption) transfer to the opposite source, if conditions permit.

#### 7ADTS

The load is disconnected and light (Figure 9) comes on during the delayed-transition transfer delay.

This completes the functional test of the transfer switch. Leave engine-generator starting control in automatic position.

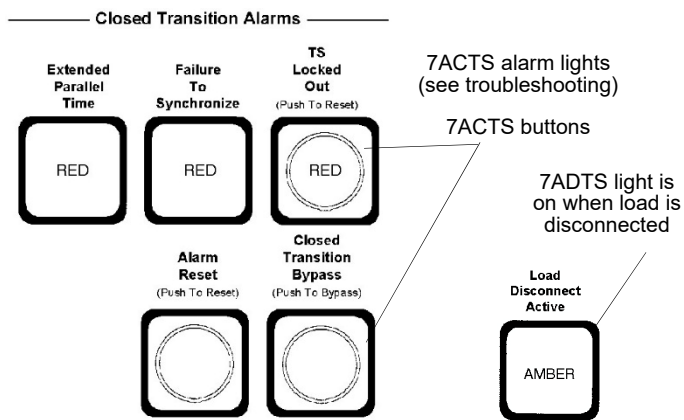

Figure 8. 7ACTS controls & lights      Figure 9. 7ADTS light

1	The <i>Transfer Switch Connected To Normal</i> and <i>Normal Source Accepted</i> lights should be on.	
2	Turn and <b>hold</b> <b>Transfer Control</b> switch clockwise to <i>Transfer Test</i> until the engine starts and runs (within 15 sec.). <i>Emergency Source Accepted</i> light should come on.	
3	Transfer switch will operate to the Emergency position after Feature 2B time delay. The <i>Transfer Switch Connected To Emergency</i> light should come on and <i>Load Connected to Normal</i> light goes off.	
4	Transfer switch will operate back to Normal position after Feature 3A time delay. For immediate retransfer turn <b>Transfer Control</b> counterclockwise to <i>Retransfer Delay Bypass</i> . The <i>Transfer Switch Connected To Normal</i> light should come on; <i>Transfer Switch Connected To Emergency</i> light should go off.	
5	The engine-generator will stop after the Feature 2E time delay (unloaded running engine cooldown). The <i>Emergency Source Accepted</i> light should go off.	

## Testing & Service

### Transfer Test

Operate the transfer switch at least once a month by following the **Electrical Operation** procedure on page 5.

### Preventive Maintenance

Reasonable care in preventive maintenance will insure high reliability and long life for the transfer switch. An annual preventive maintenance program is recommended.

ASCO Services, Inc. is ASCO Power Technologies' national service organization. They can be contacted at 1-800-800-2726 for information on preventive maintenance agreements

### Yearly Inspection



Hazardous voltage capable of causing shock, burns, or death is used in this transfer switch. Deenergize both Normal & Emergency power sources before performing inspections!

**Clean the enclosure.** Deenergize all sources, then brush and vacuum away any excessive dust accumulation. Remove moisture with a clean cloth.

**Inspect the transfer switch contacts.** Deenergize all sources, then remove the transfer switch barriers and check the contact condition. Replace contacts when pitted or worn excessively. Reinstall the barriers carefully.

**Maintain transfer switch lubrication.** Under normal operating conditions no further lubricating is required. Renew factory lubrication if the transfer switch is subjected to severe dust, abnormal operating conditions, or if the TS coil is replaced. Order lubrication kit 920836.

**Check all cable connections & retighten them.** Torque to values shown on the transfer switch label.

## Replacement Parts

When ordering replacement parts provide the Serial No., Bill of Material No. (BOM), and Catalog No. from the transfer switch nameplate.

In the US call 800-800-2726 (ASCO) or contact [customercare@ascopower.com](mailto:customercare@ascopower.com).

### Manual Load Transfer

This procedure will manually transfer the load if the controller is disconnected.



Do not manually operate the transfer switch until both power sources are disconnected: open both circuit breakers.

1. Deenergize both the normal and emergency source (open both circuit breakers).
2. Use the maintenance handle to manually operate the transfer switch to the opposite source. See pages 3, **Manual Operation**.
3. Close the enclosure door. If the transfer switch is in the emergency position, manually start the generator and then close the emergency source circuit breaker.

# Troubleshooting

Problem	Check in Numerical Sequence		
	1 Operation	2 Generator	3 Voltage
The engine-generator set does not start when the <b>Transfer Control</b> switch is turned clockwise and held in the <i>Transfer Test</i> position or when the Normal source fails.	Hold the <i>Transfer Test</i> switch for 15 seconds, or the outage must be long enough to allow for the Feature 1C time delay plus engine cranking and starting time.	Starting control must be in automatic position. Batteries must be charged and connected. Check wiring to the engine starting contacts.	-
The transfer switch does not transfer the load to the emergency source after the engine-generator set starts.	Wait for the Feature 2B time delay to time out.	Is the <i>Emergency Source Accepted</i> light on? Generator output circuit breaker must be closed. Generator frequency must be correct.	Voltmeter should read at least 90% of nominal phase to phase voltage between transfer switch terminals EA and EC (or EL1 and EL2 for 2 pole switches). * There are factory settings.
The transfer switch does not retransfer the load to the normal source when normal returns or when the <b>Transfer Control</b> switch is released.	Wait for the Feature 3A time delay. For immediate retransfer, turn the <b>Transfer Control</b> counterclockwise to <i>Retransfer Delay Bypass</i> . For 7ATS & 7ACTS, if inphase transfer is active, wait for inphase condition.	-	Voltmeter should read at least 90% of nominal phase to phase voltage between transfer switch terminals NB and NC, NC and NA, and NA and NB (or NL1 and NL2 for 2 pole switches).
The engine-generator set does not stop after load retransfer to the normal source.	Wait for the Feature 2E time delay to time out (if used).	Starting control must be in the automatic position.	-
<b>7ACTS</b> <i>Failure to Synchronize</i> light comes on.	Conditions of Normal or Emergency Sources not suitable for closed transition transfer. Recheck voltage and frequency of both sources. Press <b>Alarm Reset</b> pushbutton.		
<b>7ACTS</b> <i>Extended Parallel Time</i> light comes on.	CN and CE contacts are closed longer than setting in the Group 5 controller. Open the disconnected source circuit breaker, then call ASI for assistance.		
<b>7ACTS</b> <i>TS Locked Out</i> light comes on.	Transfer lockout operation has occurred; transfer switch is disabled from automatic operation. Open the disconnected source circuit breaker, then call ASCO Power Services, Inc for assistance.		
<b>7ADTS</b> <i>Load Disconnect Active</i> light comes on.	Delayed transition transfer operation. If load is disconnected longer than the setting in Group 5 controller (see User's Guide 381333-126), then contact ASCO Power Services, Inc. for assistance.		

# INDEX

## A

ASCO Power Services Inc.  
800-800-2726(ASCO)  
customercare@ascopower.com  
automatic operation, 5  
auxiliary circuits, 2

## B

battery, 7

## C

cables, power, 2  
connections, 2  
controller  
    see User's Guide 381333-  
    126  
controller ground, 2  
controls, 5  
cooldown, generator, 5, 7

## D

**DANGER** statements, 1, 2, 4, 6

## E

electrical operation, 5  
emergency source accepted  
light,  
    4, 5  
engine starting contacts, 2

## F

foundation, 1  
frequency, 4, 7  
functional test, 3, 4, 5

## G

generator, 2, 4, 5, 7  
ground, controller, 2

## H

harness, 2  
HELP 800-800-2726(ASCO)  
customercare@ascopower.com

## I

inphase transfer feature, 7  
inspection, 6  
installation, 2

## L

lights, 4, 5, 7  
line connections, 2  
load on emergency light, 4, 5  
load on normal light, 4, 5  
lubrication, 6

## M

maintenance, 6  
maintenance handle, 3, 6  
**WARNING**, 3, 6  
manual load transfer, 6  
**WARNING**, 3, 6  
mounting, 2

## N

normal source accepted light, 4,  
5

## O

operation, electrical, 5

## P

phase rotation, 4  
preventive maintenance, 6  
problem, 7

## R

rating label, 1  
replacement parts, 6

## S

source acceptable lights, 4, 5  
starting contacts, 2  
starting control, 5, 7  
starting problem, 7  
stopping problem, 7

## T

terminals, 2  
testing power conductors, 2  
time delays, 5, 7  
transfer button, 5, 7  
transfer problem, 7  
troubleshooting, 7

## V

voltage checks, 4, 7

## W

**WARNING** statements, 1, 3, 5, 6

ASCO Power Technologies  
160 Park Avenue  
Florham Park, NJ 07932-1591 USA  
Phone: 1 800 800-2726 (ASCO) for sales or service  
[www.ascopower.com](http://www.ascopower.com)

©2016 ASCO Power Technologies. All Rights Reserved

Printed in U.S.A