

Eaton® 93PM Integrated Accessory Cabinet-Distribution

50 kW (480V/208V) IAC-D

50 kW (208V/208V) IAC-D

100 kW (480V/208V) IAC-D

100 kW (208V/208V) IAC-D

150 kW (480V/208V) IAC-D

200 kW (480V/208V) IAC-D

Installation and Operation Manual



Powering Business Worldwide

Eaton® 93PM Integrated Accessory Cabinet-Distribution

50 kW (480V/208V) IAC-D

50 kW (208V/208V) IAC-D

100 kW (480V/208V) IAC-D

100 kW (208V/208V) IAC-D

150 kW (480V/208V) IAC-D

200 kW (480V/208V) IAC-D

Installation and Operation Manual



Powering Business Worldwide

IMPORTANT SAFETY INSTRUCTIONS SAVE THESE INSTRUCTIONS

This manual contains important instructions that should be followed during installation and maintenance of the UPS system and batteries. Read all instructions before operating the equipment and save this manual for future reference.

CONSIGNES DE SÉCURITÉ IMPORTANTES CONSERVER CES INSTRUCTIONS

Ce manuel comporte des instructions importantes que vous êtes invité à suivre lors de toute procédure d'installation et de maintenance des batteries et de l'onduleur. Veuillez consulter entièrement ces instructions avant de faire fonctionner l'équipement et conserver ce manuel afin de pouvoir vous y reporter ultérieurement.

Eaton and Cutler-Hammer are registered trademarks of Eaton or its subsidiaries and affiliates. National Electrical Code and NEC are registered trademarks of National Fire Protection Association, Inc. All other trademarks are property of their respective companies.

©Copyright 2013-2017 Eaton, Raleigh, NC, USA. All rights reserved. No part of this document may be reproduced in any way without the express written approval of Eaton.

Table of Contents

1	INTRODUCTION	1-1
1.1	Features	1-2
1.2	Installation Features	1-4
1.3	Model Configurations	1-4
1.4	Using This Manual	1-8
1.5	Conventions Used in This Manual	1-8
1.6	Symbols, Controls, and Indicators	1-8
1.7	For More Information	1-9
1.8	Getting Help	1-9
2	SAFETY WARNINGS	2-1
SECTION 1 — INSTALLATION		
3	INSTALLATION PLAN AND UNPACKING	3-1
3.1	Creating an Installation Plan	3-1
3.2	Preparing the Site	3-1
3.2.1	Environmental and Installation Considerations	3-1
3.2.2	IAC-D Power Wiring Preparation	3-9
3.2.3	208V/208V IAC-D Power Wiring Preparation with Maintenance Bypass	3-9
3.3	Inspecting and Unpacking the IAC-D	3-17
4	INSTALLATION	4-1
4.1	Preliminary Installation Information	4-1
4.2	Unloading the IAC-D Cabinet from the Pallet	4-1
4.3	Installing IAC-D External Power Wiring	4-7
4.3.1	Input Wiring (480V/208V)	4-7
4.3.2	Input Wiring (208V/208V)	4-10
4.3.3	50 kW and 100 kW Output Wiring	4-15
4.3.4	Two-Hole Barrel Lug Terminations to Bus Bar Installation	4-24
4.3.5	150 kW and 200 kW Output Wiring	4-24
4.4	Adjustable Subfeed Breakers	4-30
4.5	Neutral CT Interface Wiring	4-31
4.5.1	Line-Up-and-Match Configuration	4-31
4.6	Initial Startup	4-38
4.7	Completing the Installation Checklist	4-38
SECTION 2 — OPERATION		
5	ONELINES AND SCHEMATICS	5-1
5.1	Onelines	5-1
5.2	Schematics	5-5
6	INTEGRATED ACCESSORY CABINET-DISTRIBUTION OPERATING INSTRUCTIONS	6-1
6.1	IAC-D Breakers	6-1
6.2	IAC-D Operation	6-2

Table of Contents

- 7 MAINTENANCE..... 7-1**
 - 7.1 Important Safety Instructions 7-1
 - 7.2 Performing Preventive Maintenance..... 7-1
 - 7.2.1 DAILY Maintenance 7-1
 - 7.2.2 PERIODIC Maintenance 7-1
 - 7.2.3 ANNUAL Maintenance 7-1
 - 7.3 Maintenance Training 7-1

- 8 PRODUCT SPECIFICATIONS..... 8-1**
 - 8.1 Model Numbers 8-1
 - 8.2 Specifications 8-1
 - 8.2.1 Input 8-1
 - 8.2.2 Output 8-1
 - 8.2.3 Environmental and Safety Specifications 8-2

- WARRANTY..... W-1**

List of Figures

Figure 1-1.	Eaton 93PM IAC-D	1-1
Figure 1-3.	Eaton 93PM 50 kW, 100 kW, and 150 kW Capacity UPS with Right-Mounted Eaton 93PM IAC-D.	1-6
Figure 1-4.	Eaton 93PM 200 kW UPS with Left-Mounted Eaton 93PM IAC-D	1-7
Figure 1-5.	Eaton 93PM 200 kW UPS with Right-Mounted Eaton 93PM IAC-D.	1-7
Figure 3-1.	93PM IAC-D Cabinet Dimensions (Front, Right Side, and Back Views)	3-4
Figure 3-6.	Cabinet Ventilation – 50 kW and 100 kW (208V/208V), and 150kW and 200 kW (480V/208V) Top Exhaust	3-8
Figure 3-7.	Eaton 93PM IAC-D as Shipped on Metal and Wood Pallet	3-18
Figure 4-4.	Input Power Terminal Locations – 480V/208V.	4-8
Figure 4-5.	UPS Output Breaker Power Terminal Detail – 480V/208V	4-9
Figure 4-6.	Input Power Terminal Locations – 208V/208V.	4-13
Figure 4-7.	208 VAC Input to IAC-D from Utility Source Terminal Detail – 208V/208V	4-14
Figure 4-8.	UPS Input Breaker Power Terminal Detail – 208V/208V	4-14
Figure 4-9.	480 VAC Input to IAC-D from UPS Terminal Detail – 208V/208V	4-15
Figure 4-12.	Bottom Subfeed Breaker Output Power Terminal Detail	4-19
Figure 4-14.	Subfeed Breaker Output Power Terminal Detail	4-21
Figure 4-16.	Output Breaker Output Power Terminal Detail – 50 kW and 100 kW.	4-23
Figure 4-17.	Typical Bus Bar Barrel Lug Mounting – Hardware Assembly Sequence	4-24
Figure 4-19.	Single Subfeed Breaker Output Power Terminal Detail – 150 kW and 200 kW	4-27
Figure 4-21.	Output Breaker Output Power Terminal Detail – 150 kW and 200 kW	4-29
Figure 4-22.	93PM IAC-D Neutral CT Interface Terminal Location	4-33
Figure 4-23.	93PM IAC-D Neutral CT Interface Terminal Detail	4-34
Figure 4-24.	50 kW UPS Neutral CT Interface Terminal Location	4-35
Figure 4-25.	100 kW and 150 kW Capacity UPS Neutral CT Interface Terminal Location.	4-36
Figure 4-26.	150 kW Redundant and 200 kW UPS Neutral CT Interface Terminal Location.	4-37
Figure 5-1.	93PM IAC-D (480V/208V) Internal Oneline – 50 kW, 100 kW, 150 kW, and 200 kW with Two PRL1A Panelboards.	5-1
Figure 5-2.	93PM IAC-D (480V/208V) Internal Oneline – 150 kW and 200 kW with Two PRL1A Panelboards and Optional Single Subfeed Breaker	5-1
Figure 5-3.	93PM IAC-D (480V/208V) Internal Oneline – 50 kW, 100 kW, 150 kW, and 200 kW with Top PRL1A Panelboard and Three 100–250A Adjustable Subfeed Breakers	5-2
Figure 5-4.	93PM IAC-D (480V/208V) Internal Oneline – 50 kW, 100 kW, 150 kW, and 200 kW with Five 100–250A Adjustable Subfeed Breakers	5-2
Figure 5-5.	93PM IAC-D (480V/208V) Internal Oneline – 175A, 350A, 600A, or 700A Output Breaker.	5-3
Figure 5-6.	93PM IAC-D (208V/208V) Internal Oneline – 50 kW and 100 kW with Top PRL1A Panelboard and Three 100–250A Adjustable Subfeed Breakers	5-3
Figure 5-7.	93PM IAC-D (208V/208V) Internal Oneline – 50 kW and 100 kW with Five 100–250A Adjustable Subfeed Breakers	5-4
Figure 5-8.	93PM IAC-D (208V/208V) Internal Oneline – 50 kW with 175A Output Breaker or 100 kW with 350A Output Breaker	5-4
Figure 6-1.	93PM IAC-D Breakers – Two Panelboards	6-3
Figure 6-2.	93PM IAC-D Breakers – Top Panelboard with Subfeed Breakers	6-4
Figure 6-3.	93PM IAC-D Breakers – Subfeed Breakers.	6-5
Figure 6-4.	93PM IAC-D Breakers – Output Breaker.	6-6

List of Figures

This page intentionally left blank.

List of Tables

Table 3-1.	Air Conditioning or Ventilation Requirements During Full Load Operation	3-2
Table 3-2.	IAC-D Cabinet Weights	3-2
Table 3-3.	IAC-D Cabinet Clearances	3-3
Table 3-4.	External Input Power Wiring Recommendations for the Eaton 93PM IAC-D (480V/208V)	3-10
Table 3-5.	External Input Power Wiring Recommendations for the Eaton 93PM IAC-D (208V/208V)	3-10
Table 3-6.	External Output Power Wiring Recommendations for the Eaton 93PM IAC-D (480V/208V)	3-11
Table 3-7.	External Output Power Wiring Recommendations for the Eaton 93PM IAC-D (208V/208V)	3-12
Table 3-8.	External Input Power Cable Terminations for the Eaton 93PM IAC-D (480V/208V)	3-13
Table 3-9.	External Input Power Cable Terminations for the Eaton 93PM IAC-D (208V/208V)	3-14
Table 3-10.	External Critical Load Output Power Cable Terminations for the Eaton 93PM IAC-D.	3-15
Table 3-11.	Supplied External Wiring Terminal Hardware Kit.	3-16
Table 3-12.	Recommended Installation Parts and Tools (Not Supplied by Eaton)	3-16
Table 3-13.	Recommended 208 Vac Input Circuit Breaker Rating	3-16
Table 4-1.	Subfeed Breaker Continuous Current (I _r) Settings	4-30
Table 4-2.	IAC-D Neutral CT Interface Wiring Terminal Block Terminations	4-34

This page intentionally left blank.

Chapter 1 Introduction

The Eaton® 93PM Integrated Accessory Cabinet-Distribution (IAC-D) is designed for use with the Eaton 93PM Series Uninterruptible Power Supplies (UPSs). The IAC-D provides power distribution options for servers, racks, and other equipment via distribution panelboards, or distributes power to larger loads via distribution subfeed circuit breakers. The distribution options are custom configurable, enabling adaptation and expansion without costly electrical rework. Four 480V/208V models are available, the 93PM 50 kW IAC-D, the 93PM 100 kW IAC-D, 93PM 150 kW IAC-D, and the 93PM 200 kW IAC-D. Two 208V/208V models are available, the 93PM 50 kW IAC-D and the 93PM 100 kW IAC-D.

The IAC-D is housed in a single free-standing cabinet with safety shields behind the front door for hazardous voltage protection. The cabinets match the UPS cabinet in style and color.

Figure 1-1 shows the Eaton 93PM IAC-D.

NOTE Startup and operational checks must be performed by an authorized Eaton Customer Service Engineer, or the warranty terms specified on page W-1 become void. This service is offered as part of the sales contract for the UPS. Contact an Eaton service representative in advance (usually a two-week notice is required) to reserve a preferred startup date.

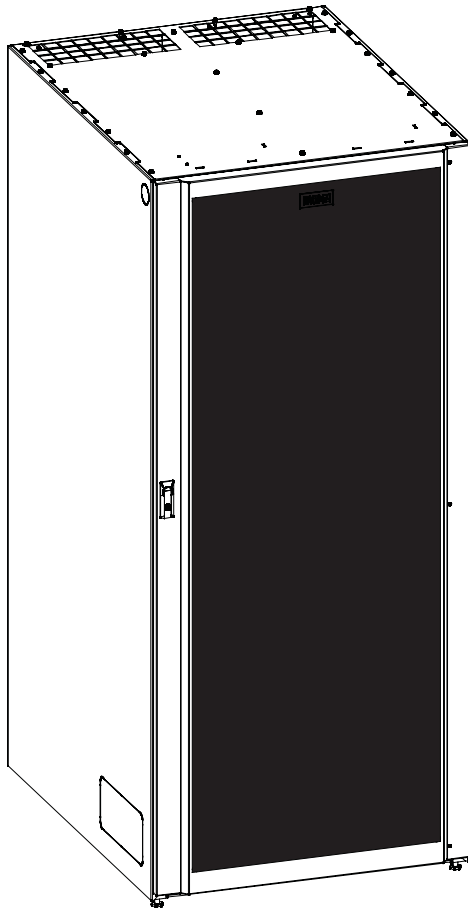

Figure 1-1. Eaton 93PM IAC-D

1.1 Features

- 50 kW features:
 - 480/208 Vac output transformer provides 208 Vac output from the 480 Vac UPS output for applications that require 208 Vac, and for use with the distribution panels supplying 208/120 Vac to the critical load.
 - Up to two optional output distribution panels distributes the output power from the UPS to the load. The distribution panels are behind the door on the front of the IAC-D. Each 225A distribution panel with a 225A main breaker can hold up to the equivalent of 42 single-pole branch circuit breakers (Cutler-Hammer® bolt-on type BAB or QBHW) that can be configured to meet facility needs.
 - Up to five optional 100-250A adjustable output distribution breakers are available to distribute the output power from the UPS to larger critical loads. The breakers have adjustable trip rating and are enclosed behind the hinged doors and trim panels on the front of the IAC-D.
 - A no distribution option provides a single 175A output breaker.
 - Neutral Current Monitoring available at the UPS display.
 - Optional factory pre-wiring to allow subfeed breakers to be field installed.
- 50 kW (208V/208V) features:
 - Optional 208/480 Vac input transformer provides conversion from 208 Vac facility power to feed the 93PM UPS 480 Vac input.
 - 480/208 Vac output transformer provides 208 Vac output from the 480 Vac UPS output for applications that require 208 Vac, and for use with the distribution panels supplying 208/120 Vac to the critical load.
 - Can be used with a three-breaker Sidecar Integrated Accessory Cabinet-Bypass (SIAC-B) or wall mount maintenance bypass.
 - One optional output distribution panel distributes the output power from the UPS to the load. The distribution panel is behind the door on the front of the IAC-D. The 225A distribution panel with a 225A main breaker can hold up to the equivalent of 42 single-pole branch circuit breakers (Cutler-Hammer bolt-on type BAB or QBHW) that can be configured to meet facility needs.
 - Up to five optional 100-250A adjustable output distribution breakers are available to distribute the output power from the UPS to larger critical loads. The breakers have adjustable trip rating and are enclosed behind the hinged doors and trim panels on the front of the IAC-D.
 - A no distribution option provides a single 175A output breaker.
 - Neutral Current Monitoring available at the UPS display.
 - Optional factory pre-wiring to allow subfeed breakers to be field installed.
- 100 kW features:
 - 480/208 Vac output transformer provides 208 Vac output from the 480 Vac UPS output for applications that require 208 Vac, and for use with the distribution panels supplying 208/120 Vac to the critical load.
 - Up to two optional output distribution panels distributes the output power from the UPS to the load. The distribution panels are behind the door on the front of the IAC-D. Each 225A distribution panel with a 225A main breaker can hold up to the equivalent of 42 single-pole branch circuit breakers (Cutler-Hammer bolt-on type BAB or QBHW) that can be configured to meet facility needs.
 - Up to five optional 100-250A adjustable output distribution breakers are available to distribute the output power from the UPS to larger critical loads. The breakers have adjustable trip rating and are enclosed behind the hinged doors and trim panels on the front of the IAC-D.
 - A no distribution option provides a single 350A output breaker.
 - Neutral Current Monitoring available at the UPS display.
 - Optional factory pre-wiring to allow subfeed breakers to be field installed.

- 100 kW (208V/208V) features:
 - Optional 208/480 Vac input transformer provides conversion from 208 Vac facility power to feed the 93PM UPS 480 Vac input.
 - 480/208 Vac output transformer provides 208 Vac output from the 480 Vac UPS output for applications that require 208 Vac, and for use with the distribution panels supplying 208/120 Vac to the critical load.
 - Can be used with a three-breaker Sidecar Integrated Accessory Cabinet-Bypass (SIAC-B) or wall mount maintenance bypass.
 - One optional output distribution panel distributes the output power from the UPS to the load. The distribution panel is behind the door on the front of the IAC-D. The 225A distribution panel with a 225A main breaker can hold up to the equivalent of 42 single-pole branch circuit breakers (Cutler-Hammer bolt-on type BAB or QBHW) that can be configured to meet facility needs.
 - Up to five optional 100-250A adjustable output distribution breakers are available to distribute the output power from the UPS to larger critical loads. The breakers have adjustable trip rating and are enclosed behind the hinged doors and trim panels on the front of the IAC-D.
 - A no distribution option provides a single 350A output breaker.
 - Neutral Current Monitoring available at the UPS display.
 - Optional factory pre-wiring to allow subfeed breakers to be field installed.
- 150 kW features:
 - 480/208 Vac output transformer provides 208 Vac output from the 480 Vac UPS output for applications that require 208 Vac, and for use with the distribution panels supplying 208/120 Vac to the critical load.
 - Up to two optional output distribution panels distributes the output power from the UPS to the load. The distribution panels are behind the door on the front of the IAC-D. Each 225A or 400A distribution panel can hold up to 42 single-pole branch circuit breakers (either Cutler-Hammer bolt-on type BAB or QBHW that can be configured to meet facility needs.
 - An optional single 225A distribution breaker for use with two panel board configurations.
 - Up to five optional 100-250A adjustable output distribution breakers are available to distribute the output power from the UPS to larger critical loads. The breakers have adjustable trip rating and are enclosed behind the hinged doors and trim panels on the front of the IAC-D.
 - A no distribution option provides a single 600A output breaker.
 - Optional Neutral Current Monitoring available at the UPS display.
 - Optional factory pre-wiring to allow subfeed breakers to be field installed

- 200 kW features:
 - 480/208 Vac output transformer provides 208 Vac output from the 480 Vac UPS output for applications that require 208 Vac, and for use with the distribution panels supplying 208/120 Vac to the critical load.
 - Up to two optional output distribution panels distributes the output power from the UPS to the load. The distribution panels are behind the door on the front of the IAC-D. Each 225A or 400A distribution panel can hold up to 42 single-pole branch circuit breakers (either Cutler-Hammer bolt-on type BAB or QBHW that can be configured to meet facility needs.
 - An optional single 225A distribution breaker for use with two panel board configurations.
 - Up to five optional 100-250A adjustable output distribution breakers are available to distribute the output power from the UPS to larger critical loads. The breakers have adjustable trip rating and are enclosed behind the hinged doors and trim panels on the front of the IAC-D.
 - A no distribution option provides a single 700A output breaker.
 - Neutral Current Monitoring available at the UPS display.
 - Optional factory pre-wiring to allow subfeed breakers to be field installed.

1.2 Installation Features

- The IAC-D is designed to be installed in line-up-and-match or standalone configurations:
 - In line-up-and-match configurations input power wiring is routed through the side panels between the UPS and the IAC-D.
 - In standalone configurations input power wiring is routed using external conduit through top or bottom entry conduit plates.
 - Output wiring is routed using external conduit through top or bottom entry conduit plates.
- To reduce installation time, connections to the input, distribution panel, and output breakers are made to easily accessible mechanical lug terminals on the breakers located at the front of the cabinet. Subfeed breaker output connections are made to mechanical lug terminal blocks also located at the front of the cabinet
- Top exhaust or rear ventilation is available
- The cabinet can be leveled and secured in place using leveling feet

A line-up-and-match IAC-D is installed adjacent to the UPS or other accessory cabinet. The recommended installation location is on the left side of the UPS cabinet as viewed from the front of the cabinets. However, the IAC-D may be installed on the right side of the UPS cabinet. See Figure 1-2 through Figure 1-5 for line-up-and-match configuration views.

1.3 Model Configurations

The following 93PM IAC-D model configurations are available for use with the 93PM UPS Series:

- 50 kW IAC-D with 480/208 Vac output transformer and:
 - Up to two PRL1A 225A 42-pole distribution panels.
 - One PRL1A 225A 42-pole distribution panel and up to three JG-Frame 3-pole 100-250A adjustable subfeed distribution breakers.
 - Up to five JG-Frame 3-pole 100-250A adjustable subfeed distribution breakers.
 - One K-Frame 3-pole 175A output breaker.

- 50 kW IAC-D with 208/480 input transformer, 480/208 Vac output transformer and:
 - One PRL1A 225A 42-pole distribution panel.
 - One PRL1A 225A 42-pole distribution panel and up to three JG-Frame 3-pole 100-250A adjustable subfeed distribution breakers.
 - Up to five JG-Frame 3-pole 100-250A adjustable subfeed distribution breakers.
 - One LG-Frame 3-pole 175A output breaker.
- 100 kW IAC-D with 480/208 Vac output transformer and:
 - Up to two PRL1A 225A 42-pole distribution panels.
 - One PRL1A 225A 42-pole distribution panel and up to three JG-Frame 3-pole 100-250A adjustable subfeed distribution breakers.
 - Up to five JG-Frame 3-pole 100-250A adjustable subfeed distribution breakers.
 - One LG-Frame 3-pole 350A output breaker.
- 100 kW IAC-D with 208/480 input transformer, 480/208 Vac output transformer and:
 - One PRL1A 225A 42-pole distribution panel.
 - One PRL1A 225A 42-pole distribution panel and up to three JG-Frame 3-pole 100-250A adjustable subfeed distribution breakers.
 - Up to five JG-Frame 3-pole 100-250A adjustable subfeed distribution breakers.
 - One LG-Frame 3-pole 350A output breaker.
- 150 kW IAC-D with 480/208 Vac output transformer and:
 - Up to two PRL1A 225A 42-pole distribution panels.
 - Up to two PRL1A 225A 42-pole distribution panels and one FD-Frame 3-pole 225A subfeed distribution breaker.
 - One PRL1A 225A 42-pole distribution panel and one PRL1A 400A 42-pole branch distribution panel.
 - One PRL1A 225A 42-pole distribution panel, one PRL1A 400A 42-pole branch distribution panel, and one FD-Frame 3-pole 225A subfeed distribution breaker.
 - One PRL1A 225A 42-pole distribution panel and up to three JG-Frame 3-pole 100-250A adjustable subfeed distribution breakers.
 - Up to five JG-Frame 3-pole 100-250A adjustable subfeed distribution breakers.
 - One LG-Frame 3-pole 600A output breaker.
- 200 kW IAC-D with 480/208 Vac output transformer and:
 - Up to two PRL1A 225A 42-pole distribution panels.
 - Up to two PRL1A 225A 42-pole distribution panels and one FD-Frame 3-pole 225A subfeed distribution breaker.
 - One PRL1A 225A 42-pole distribution panel and one PRL1A 400A 42-pole branch distribution panel.
 - One PRL1A 225A 42-pole distribution panel, one PRL1A 400A 42-pole branch distribution panel, and one FD-Frame 3-pole 225A subfeed distribution breaker.
 - One PRL1A 225A 42-pole distribution panel and up to three JG-Frame 3-pole 100-250A adjustable subfeed distribution breakers.
 - Up to five JG-Frame 3-pole 100-250A adjustable subfeed distribution breakers.
 - One MD-Frame 3-pole 700A output breaker.

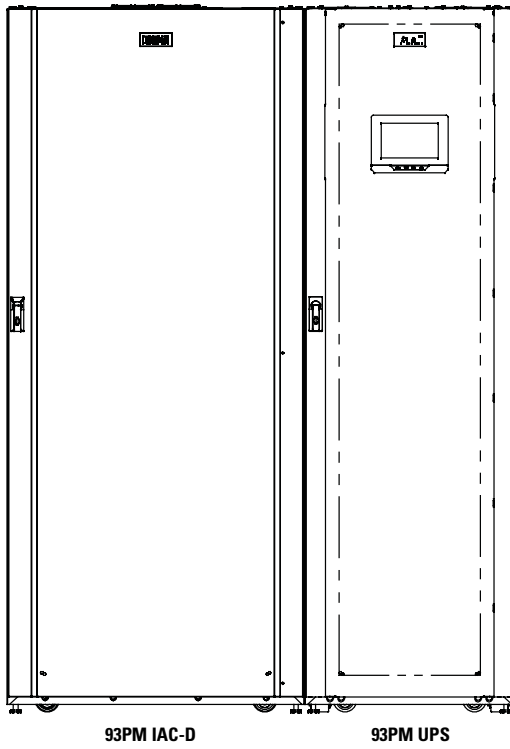

Figure 1-2. Eaton 93PM 50 kW, 100 kW, and 150 kW Capacity UPS with Left-Mounted Eaton 93PM IAC-D

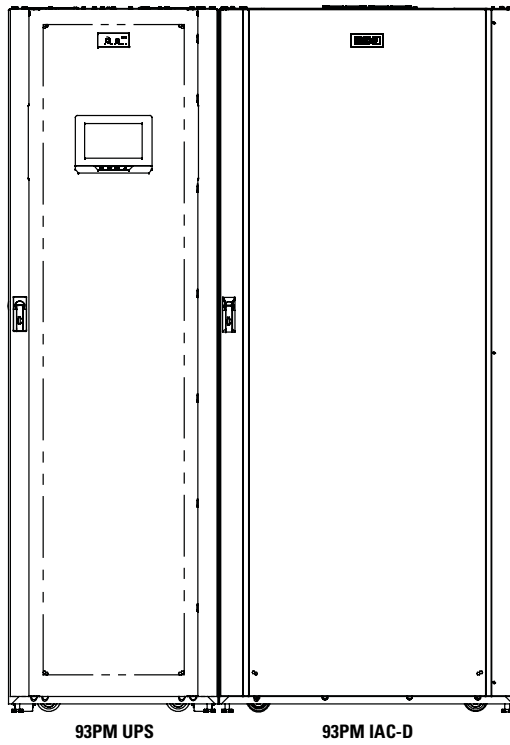

Figure 1-3. Eaton 93PM 50 kW, 100 kW, and 150 kW Capacity UPS with Right-Mounted Eaton 93PM IAC-D

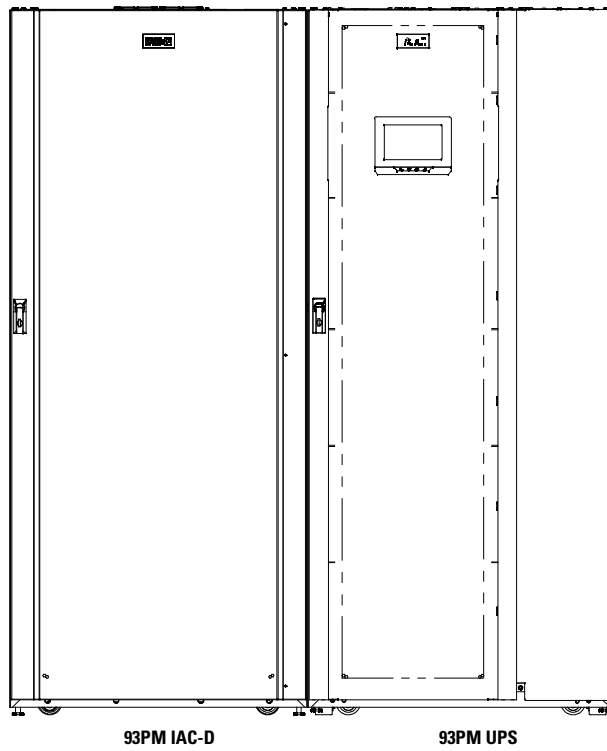

Figure 1-4. Eaton 93PM 200 kW UPS with Left-Mounted Eaton 93PM IAC-D

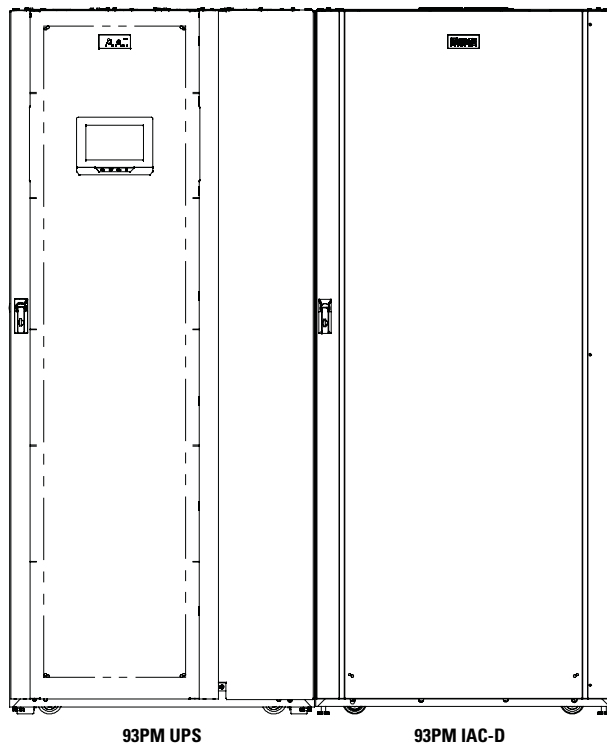

Figure 1-5. Eaton 93PM 200 kW UPS with Right-Mounted Eaton 93PM IAC-D

1.4 Using This Manual

This manual describes how to install the IAC-D. Read and understand the procedures described to ensure trouble-free installation and operation.

Read through each procedure before beginning the procedure. Perform only those procedures that apply to the UPS system being installed or operated.

1.5 Conventions Used in This Manual

This manual uses these type conventions:

- **Bold type** highlights important concepts in discussions, key terms in procedures, and menu options, or represents a command or option that you type or enter at a prompt.
- *Italic type* highlights new terms where they are defined.
- `Screen type` represents information that appears on the screen or LCD.

Icon	Description
NOTE	Information notes provide pertinent information about important features or instructions.
[Keys]	Brackets are used when referring to a specific key, such as [Enter] or [Ctrl].

In this manual, the term *UPS* refers only to the UPS cabinet and its internal elements. The term *UPS system* refers to the entire power protection system – the UPS cabinet, an external battery system, and options or accessories installed.

The term *line-up-and-match* refers to accessory cabinets that are physically located adjacent to the UPS. The term *standalone* refers to accessory cabinets that are located separate from the UPS.

1.6 Symbols, Controls, and Indicators

The following are examples of symbols used on the UPS or accessories to alert you to important information:



RISK OF ELECTRIC SHOCK - Observe the warning associated with the risk of electric shock symbol.



CAUTION: REFER TO OPERATOR'S MANUAL - Refer to your operator's manual for additional information, such as important operating and maintenance instructions.



This symbol indicates that you should not discard the UPS or the UPS batteries in the trash. This product contains sealed, lead-acid batteries and must be disposed of properly. For more information, contact your local recycling/reuse or hazardous waste center.



This symbol indicates that you should not discard waste electrical or electronic equipment (WEEE) in the trash. For proper disposal, contact your local recycling/reuse or hazardous waste center.

1.7 For More Information

Refer to the *Eaton 93PM UPS (20–50 kW, 480V – 50 kW Frame) Installation and Operation Manual*, the *Eaton 93PM UPS (20–100 kW, 480V – 100 kW Frame) Installation and Operation Manual*, the *Eaton 93PM UPS (20–150 kW, 480V – 150 kW Capacity Frame) Installation and Operation Manual*, or the *Eaton 93PM UPS (20–200 kW, 480V – 200 kW Frame) Installation and Operation Manual* for the following additional information:

- UPS, optional components, and accessory installation instructions, including site preparation, planning for installation, wiring and safety information, and detailed illustrations of cabinets and optional accessories with dimensional and connection point drawings
- UPS operation, including UPS controls, functions of the UPS, standard features and optional accessories, procedures for starting and stopping the UPS, and information about maintenance and responding to system events
- Communication capabilities of the UPS system

Refer to the *Eaton 93PM Sidecar Integrated Accessory Cabinet-Bypass (100 kW SIAC-B) Installation and Operation Manual* for the following additional information:

- Installation instructions, including site preparation, planning for installation, wiring and safety information, and detailed illustrations of cabinets with dimensional and connection point drawings
- Operation, including breakers, standard features and optional accessories, procedures for using the bypass functions, and information about maintenance

Visit www.eaton.com/powerquality or contact an Eaton service representative for information on how to obtain copies of these manuals.

1.8 Getting Help

If help is needed with any of the following:

- Scheduling initial startup
- Regional locations and telephone numbers
- A question about any of the information in this manual
- A question this manual does not answer

Please call the Customer Reliability Center at:

United States: **1-800-843-9433**
Canada: **1-800-461-9166 ext 260**
All other countries: **Call your local service representative**

Please use the following e-mail address for manual comments, suggestions, or to report an error in this manual:

E-ESSDocumentation@eaton.com

This page intentionally left blank.

Chapter 2 Safety Warnings

IMPORTANT SAFETY INSTRUCTIONS SAVE THESE INSTRUCTIONS

This manual contains important instructions that should be followed during installation and maintenance of the UPS system and batteries. Read all instructions before operating the equipment and save this manual for future reference.

The UPS system is designed for industrial or computer room applications, and contains safety shields behind the door and front panels. However, the UPS system is a sophisticated power system and should be handled with appropriate care.

DANGER

This UPS system contains LETHAL VOLTAGES. All repairs and service should be performed by AUTHORIZED SERVICE PERSONNEL ONLY. There are NO USER SERVICEABLE PARTS inside the UPS.

WARNING

- The UPS system is powered by its own energy source (batteries). The output terminals may carry live voltage even when the UPS is disconnected from an AC source.
 - To reduce the risk of fire or electric shock, install this UPS system in a temperature and humidity controlled, indoor environment, free of conductive contaminants. Ambient temperature must not exceed 40°C (104°F). Do not operate near water or excessive humidity (95% maximum). The system is not intended for outdoor use.
 - As a result of the connected loads, high leakage current is possible. Connection to earth ground is required for safety and proper product operation. Do not check UPS system operation by any action that includes removal of the earth (ground) connection with loads attached.
 - Ensure all power is disconnected before performing installation or service.
 - ELECTRIC ENERGY HAZARD. Do not attempt to alter any UPS system or battery wiring or connectors. Attempting to alter wiring can cause injury.
-

CAUTION

- Installation or servicing should be performed by qualified service personnel knowledgeable of UPS and battery systems, and required precautions. Keep unauthorized personnel away from equipment. Consider all warnings, cautions, and notes before installing or servicing equipment.
 - Keep the Accessory cabinet doors closed and front panels installed to ensure proper cooling airflow and to protect personnel from dangerous voltages inside the unit.
 - Do not install or operate the UPS system close to gas or electric heat sources.
 - The operating environment should be maintained within the parameters stated in this manual.
 - Keep surroundings uncluttered, clean, and free from excess moisture.
 - Observe all DANGER, WARNING, and CAUTION notices affixed to the inside and outside of the equipment.
-

This page intentionally left blank.

Section 1

Installation

Chapter 3 Installation Plan and Unpacking

Use the following basic sequence of steps to install the Eaton 93PM Integrated Accessory Cabinet-Distribution (IAC-D):

1. Create an installation plan for the IAC-D (Chapter 3).
2. Prepare your site for the IAC-D (Chapter 3).
3. Inspect and unpack the IAC-D (Chapter 3).
4. Unload and install the IAC-D, and wire the system (Chapter 4).
5. Complete the Installation Checklist (Chapter 4).
6. Have authorized service personnel perform preliminary operational checks and start up the UPS system.

NOTE  Startup and operational checks must be performed by an authorized Eaton Customer Service Engineer, or the warranty terms specified on page W-1 become void. This service is offered as part of the sales contract for the UPS. Contact an Eaton service representative in advance (usually a two-week notice is required) to reserve a preferred startup date.

3.1 Creating an Installation Plan

Before installing the IAC-D, read and understand how this manual applies to the system being installed. Use the procedures and illustrations in this section to create a logical plan for installing the IAC-D. This section contains the following information:

- Physical features and requirements, including dimensions
- Power wiring installation information

3.2 Preparing the Site

For the UPS system to operate at peak efficiency, the installation site should meet the environmental parameters outlined in this manual. The operating environment must meet the weight, clearance, and environmental requirements specified for the applicable accessory cabinet.

3.2.1 Environmental and Installation Considerations

The UPS system installation, including the IAC-D, must meet the following guidelines:

- The system must be installed on a level floor suitable for computer or electronic equipment.
- The system must be operated at an altitude no higher than 1500m (5000 ft) without derating. For additional assistance with high altitude operation, contact an Eaton service representative (see paragraph 1.8).
- The system must be installed in a temperature and humidity controlled indoor area free of conductive contaminants.

Failure to follow guidelines may void your warranty.

The basic environmental requirements for operation of the IAC-D are:

- Recommended Operating Range: 5–40°C (41–104°F)
- Maximum Relative Humidity: 95%, noncondensing

The IAC-D ventilation requirements are shown in Table 3-1.

Table 3-1. Air Conditioning or Ventilation Requirements During Full Load Operation

Model	Rating	Input/Output Voltage	Heat Rejection BTU/hr x1000 (kg-cal/hr)	Minimum Required Cooling Air Flow
Eaton 93PM 50 kW IAC-D with Standard K13 Output Transformer (non-TP1 efficiency)	50 kW	480/208	8.803 (2218)	Natural Convection
Eaton 93PM 50 kW IAC-D with Input Autotransformer and Standard K13 Output Transformer (non-TP1 efficiency)	50 kW	208/480 (input transformer) 480/208 (output transformer)	14.877 (3749)	320 liter/sec (678 cfm)
Eaton 93PM 100 kW IAC-D with Standard K13 Output Transformer (non-TP1 efficiency)	100 kW	480/208	14.268 (3594)	320 liter/sec (678 cfm)
Eaton 93PM 100 kW IAC-D with Input Autotransformer and Standard K13 Output Transformer (non-TP1 efficiency)	100 kW	208/480 (input transformer) 480/208 (output transformer)	19.176 (4832)	320 liter/sec (678 cfm)
Eaton 93PM 150 kW IAC-D with Standard K13 Output Transformer (non-TP1 efficiency)	150 kW	480/208	10.168 (2562)	320 liter/sec (678 cfm)
Eaton 93PM 200 kW IAC-D with Standard K13 Output Transformer (non-TP1 efficiency)	200 kW	480/208	11.943 (3010)	320 liter/sec (678 cfm)

The IAC-D operating environment must accommodate the weight requirements shown in Table 3-2 and the size and space requirements shown in Table 3-3 and Figure 3-1 through Figure 3-3.

Table 3-2. IAC-D Cabinet Weights

Model	Shipping	Weight kg (lb)	
		Installed	Point Loading
Eaton 93PM 50 kW IAC-D with output transformer and two panelboards	567 (1251)	521 (1149)	4 at 130 (287)
Eaton 93PM 50 kW IAC-D with input and output transformer and two panelboards	744 (1641)	698 (1539)	4 at 175 (385)
Eaton 93PM 100 kW IAC-D with output transformer and two panelboards	674 (1487)	628 (1385)	4 at 157 (346)
Eaton 93PM 100 kW IAC-D with input and output transformer and two panelboards	949 (2093)	903 (1991)	4 at 226 (498)
Eaton 93PM 150 kW IAC-D with output transformer and two panelboards	955 (2106)	909 (2004)	4 at 227 (501)
Eaton 93PM 200 kW IAC-D with output transformer and two panelboards	1023 (2256)	977 (2154)	4 at 244 (539)

Air inlets are in the bottom of the cabinet. Outlets are in the back of the cabinet for rear exhaust and in the top of the cabinet for top exhaust.

Rear exhaust (see Figure 3-4):

- 50 kW: Natural convection air cooling regulates internal component temperature
- 100 kW: Natural convection air cooling regulates internal component temperature
- 100 kW 208/208: Forced air cooling only
- 150 kW: Forced air cooling only
- 200 kW: Forced air cooling only

Top exhaust (see Figure 3-5 or Figure 3-6):

- 50 kW: Natural convection air cooling
- 100 kW: Forced air cooling only
- 100 kW 208/208: Forced air cooling only
- 150 kW: Forced air cooling only
- 200 kW: Forced air cooling only

Allow clearance on top or in back of the cabinet depending on type of exhaust for proper air circulation. The clearances required around the IAC-D cabinet are shown in Table 3-3.

Table 3-3. IAC-D Cabinet Clearances

From Front of Cabinet	914.4 mm (36") working space
From Top of Cabinet with Top Exhaust (50 kW Zone 1 – see Figure 3-5)	203 mm (8") minimum clearance for ventilation
From Top of Cabinet with Top Exhaust (100 kW, 150 kW, and 200 kW, 480V/208V Zone 1 – see Figure 3-5 or Figure 3-6)	457.2 mm (18") minimum clearance for ventilation and working space
From Top of Cabinet with Top Exhaust (50 kW and 100 kW, 208V/208V Zone 1 – see Figure 3-5 or Figure 3-6)	57.2 mm (18") minimum clearance for ventilation and working space
From Top of Cabinet with rear service access (Zone 2 – see Figure 3-5 or Figure 3-6)	Can be less than 457.2 mm (18")
From Back of Cabinet with Rear Exhaust (50 kW and 100 kW, 480V/208V)	203 mm (8") minimum clearance for ventilation
From Back of Cabinet with Rear Exhaust (150 kW and 200 kW, 480V/208V)	457.2 mm (18") minimum clearance for ventilation
From Back of Cabinet with Rear Exhaust (50 kW and 100 kW, 208V/208V)	457.2 mm (18") minimum clearance for ventilation
From Back of Cabinet – Seismic Installation	914.4 mm (36") working space
From Right Side of Cabinet	None Required
From Left Side of Cabinet	None Required

Installation Plan and Unpacking

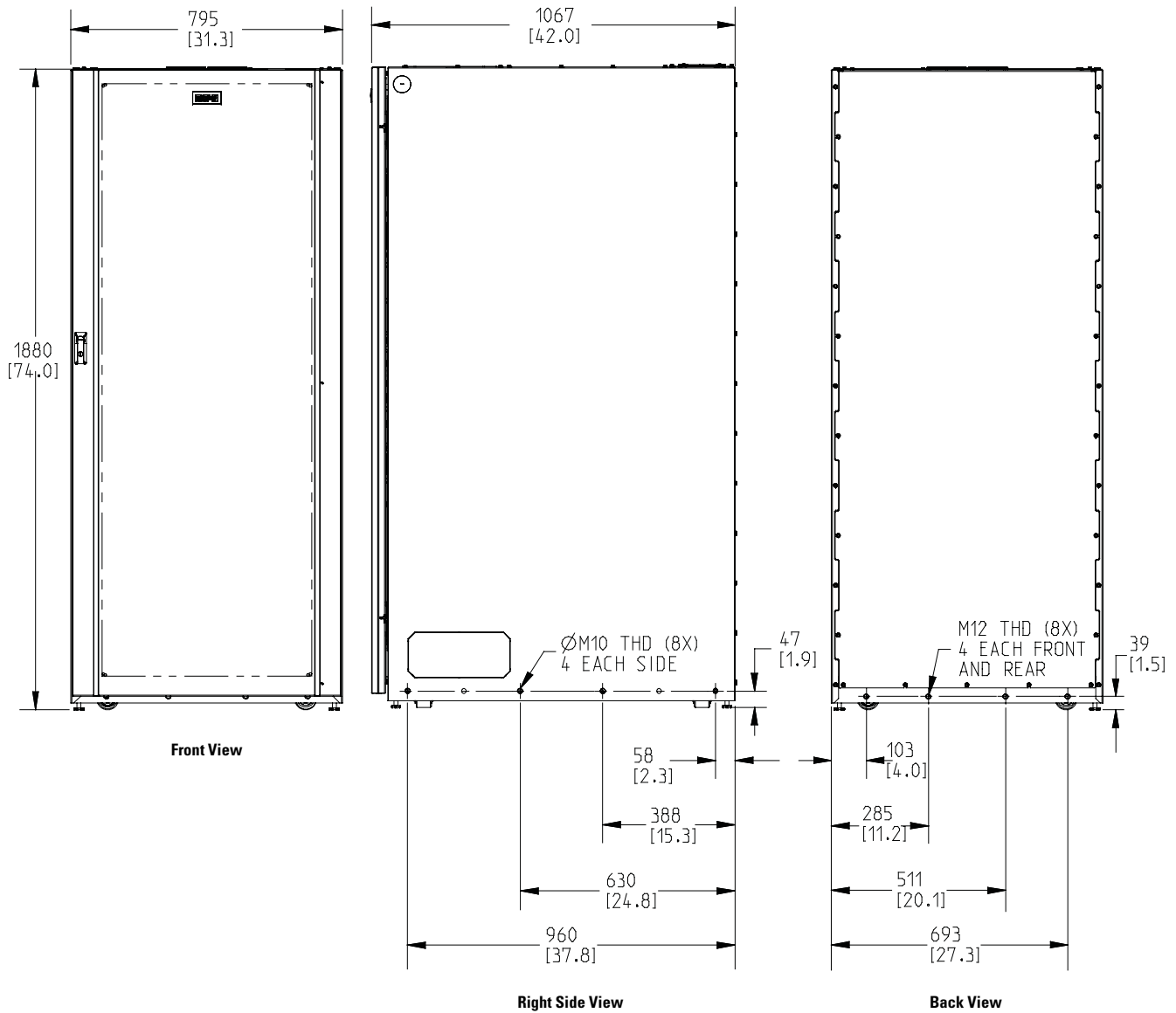

Dimensions are in millimeters [inches]

Figure 3-1. 93PM IAC-D Cabinet Dimensions (Front, Right Side, and Back Views)

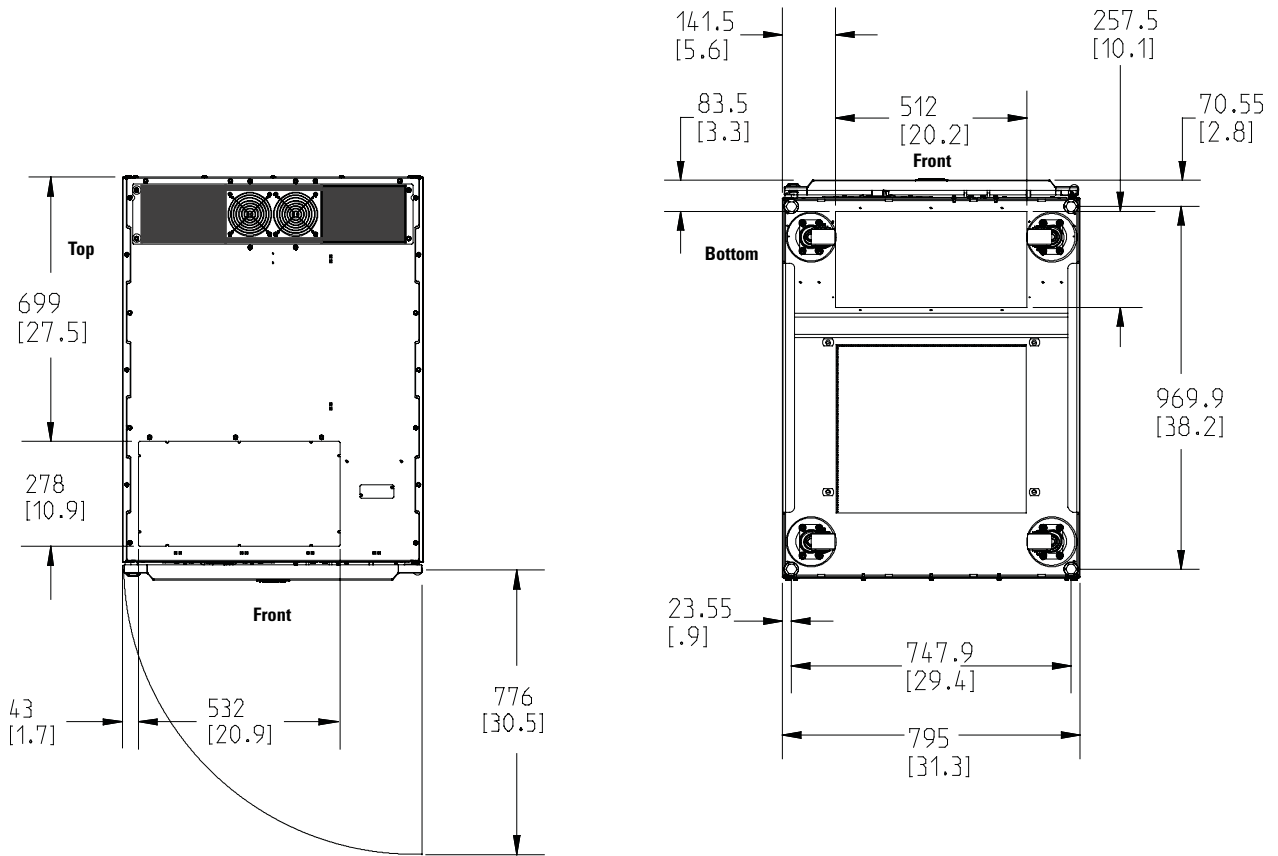

NOTE Top exhaust configuration shown.

Dimensions are in millimeters [inches]

Figure 3-2. 93PM IAC-D Dimensions (Top and Bottom Views)

Installation Plan and Unpacking

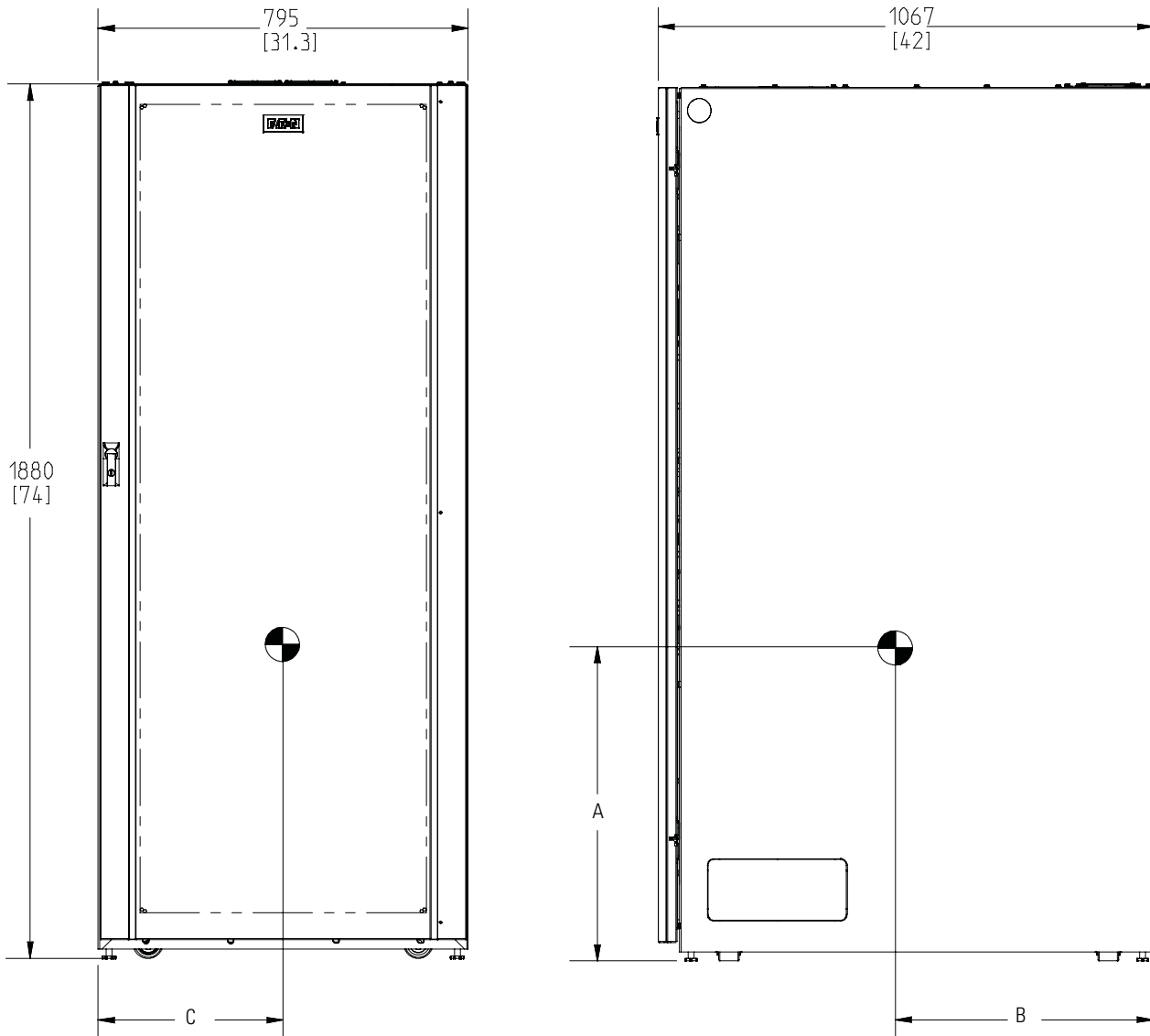

Dimensions are in millimeters [inches]

Weight and Center of Gravity				
	A	B	C	Weight
	mm (in)	mm (in)	mm (in)	kg (lb)
Eaton 93PM 50 kW IAC-D (480V/208V)	649 (25.5)	497 (19.5)	367 (14.4)	521 (1149) – Installed
Eaton 93PM 50 kW IAC-D (208V/208V)	854 (33.6)	443 (17.4)	392 (15.4)	698 (1539) – Installed
Eaton 93PM 100 kW IAC-D (480V/208V)	695 (27.4)	535 (21.0)	373 (14.7)	628 (1385) – Installed
Eaton 93PM 100 kW IAC-D (208V/208V)	906 (35.6)	437 (17.2)	363 (14.3)	903 (1991) – Installed
Eaton 93PM 150 kW IAC-D (480V/208V)	704 (27.7)	481 (18.9)	387 (15.2)	909 (2004) – Installed
Eaton 93PM 200 kW IAC-D (480V/208V)	698 (27.5)	473 (18.6)	388 (15.3)	977 (2154) – Installed

Figure 3-3. 93PM IAC-D Center of Gravity

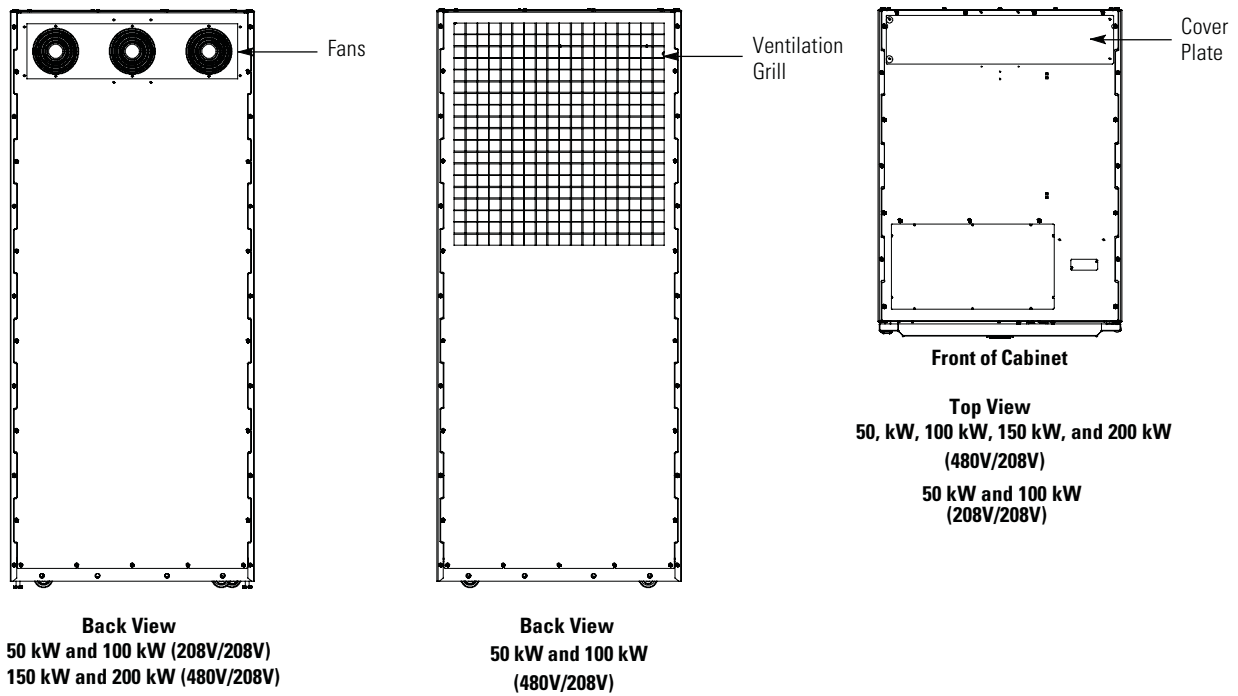
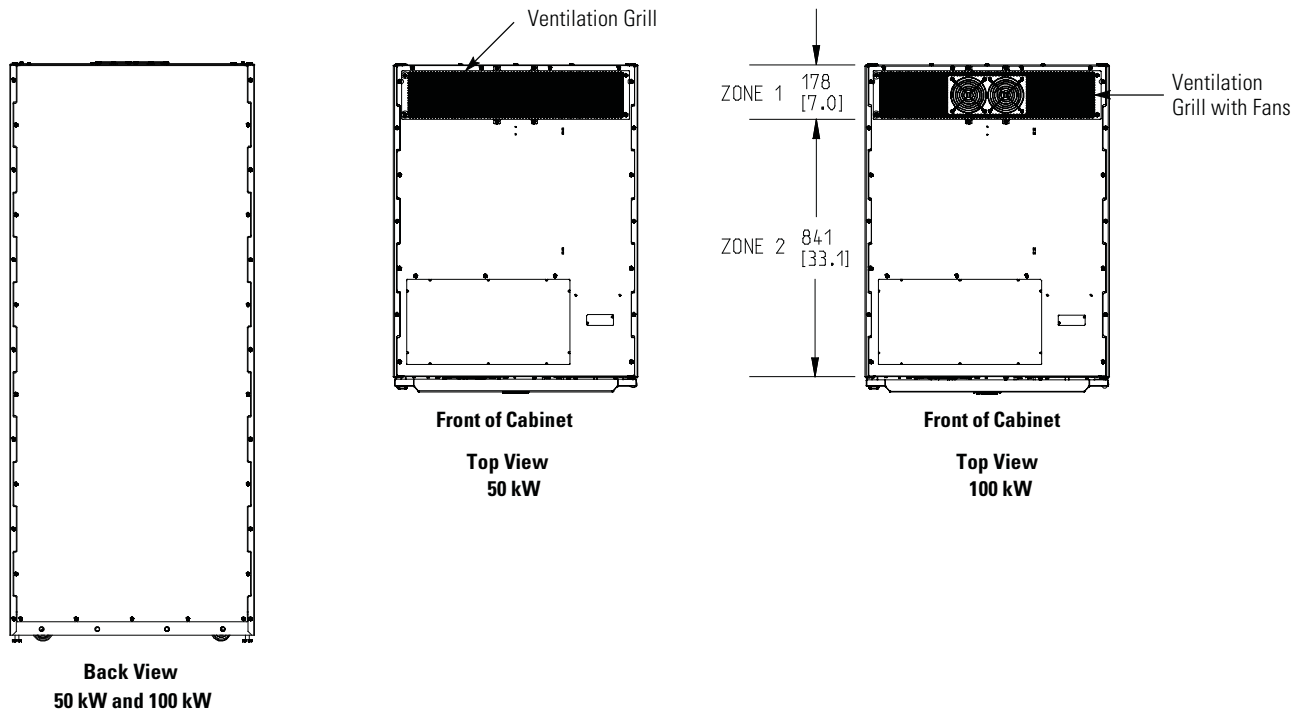
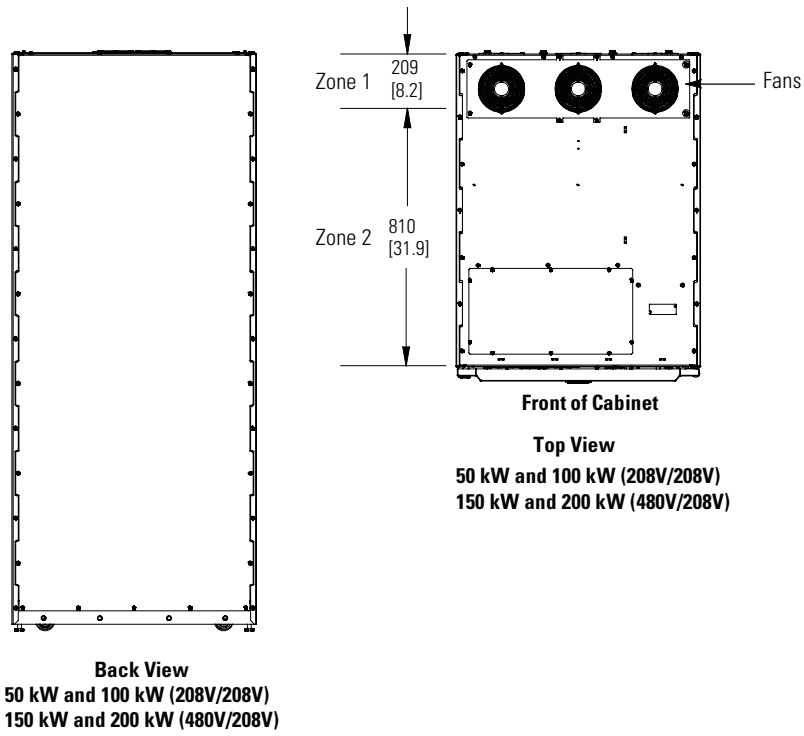

Figure 3-4. Cabinet Ventilation – 50 kW, 100 kW, 150 kW, and 200 kW Rear Exhaust



Dimensions are in millimeters [inches]

Figure 3-5. Cabinet Ventilation – 50 kW and 100 kW (480V/208V) Top Exhaust



Dimensions are in millimeters [inches]

Figure 3-6. Cabinet Ventilation – 50 kW and 100 kW (208V/208V), and 150kW and 200 kW (480V/208V) Top Exhaust

3.2.2 IAC-D Power Wiring Preparation

Read and understand the following information while planning and performing the installation:

 **WARNING**

As a result of the connected loads, high leakage current is possible. Connection to earth ground is required for safety and proper product operation. Do not check IAC-D operation by any action that includes removal of the earth (ground) connection with loads attached.

- Refer to national and local electrical codes for acceptable external wiring practices.
- For external wiring, use copper wire with 75°C rated insulation. Wire sizes listed in Table 3-4 through Table 3-7 are for copper wiring only. If wire is run in an ambient temperature greater than 40°C (104°F), higher temperature wire and/or larger size wire may be necessary. Wire sizes are based on using the specified breakers.
- Recommended wire sizes are based on NFPA National Electrical Code® (NEC®) 70 Table 310.15(B)(16) 75°C ampacity with 40°C ambient correction factors.
- 50 kW and 100 kW (208V/208V) IAC-D – 208V supply feed must be 3-wire Wye, no Delta
- Refer to NEC Article 250 and local codes for proper grounding practices.
- Per NEC Article 300-20(B), all three-phase conductors must be run in the same conduit. Neutral and ground must be run in the same conduit as the phase conductors.
- Conduit is to be sized to accommodate three phase conductors, one neutral conductor the same size as the phase conductors and one ground conductor. If two neutral conductors or an oversized neutral conductor are to be installed, size the conduit to accommodate the extra wire or size.
- 225A and 400A distribution panels use Cutler-Hammer bolt-on type BAB or QBHW breakers. Breakers are to be provided by the customer.
- Material and labor for external wiring requirements are to be provided by the customer.
- Refer to the appropriate Eaton 93PM UPS installation and operation manual listed in paragraph 1.7 for UPS cabinet conduit and terminal specifications and locations.
- The term *line-up-and-match* refers to accessory cabinets that are physically located adjacent to the UPS. The term *standalone* refers to accessory cabinets that are located separate from the UPS.

3.2.3 208V/208V IAC-D Power Wiring Preparation with Maintenance Bypass

Read and understand the following information in addition to the information in paragraph 3.2.2 while planning and performing a system installation with a single-feed UPS and a Sidecar Integrated Accessory Cabinet-Bypass (SIAC-B) or wall mount maintenance bypass:



NOTE The 208V/208V IAC-D can be used only with a three-breaker SIAC-B or wall mount maintenance bypass.

- The SIAC-B maintenance bypass input (E6,E7,E8) or wall mount maintenance bypass input must be fed from the output of the 208V/480V IAC-D input autotransformer for single-feed systems when using a three-breaker bypass. This must be a 480V feed.
- The 480V output of the UPS (E9, E10, and E11) is wired to the SIAC-B or wall mount maintenance bypass MIS input.
- The 480V output from the SIAC-B (E9, E10, and E11) or wall mount maintenance bypass is wired to the 480V input of IAC-D.

Installation Plan and Unpacking

For external input power wiring recommendations, including the minimum AWG size of external wiring, see Table 3-4 for 480V/208V IAC-D and Table 3-5 for 208V/208V IAC-D. Wire sizes listed are for copper wiring only.

Table 3-4. External Input Power Wiring Recommendations for the Eaton 93PM IAC-D (480V/208V)

Basic Unit Rating	Units		Ratings			
	kW		50	100	150	200
Input Voltage	Volts		480	480	480	480
480 VAC Input to IAC-D from UPS (3) Phases, (1) Ground	A	Maximum Amps	60	120	180	240
Minimum Conductor Size (Phase A, B, and C) Number per Phase		AWG or kcmil (each)	3 (1)	2/0 (1)	2/0 (2)	2/0 (2)
Minimum Conductor Size (Ground) Number		AWG or kcmil (each)	8 (1)	6 (1)	4 (2)	1 (1)
NOTE Callout letter A maps to Figure 5-1 through Figure 5-5.						

Table 3-5. External Input Power Wiring Recommendations for the Eaton 93PM IAC-D (208V/208V)

Basic Unit Rating	Units		Ratings	
	kW		50	100
Input Voltage	Volts		208	208
208 VAC Input to IAC-D from Utility Source (3) Phases, (1) Ground	A	Maximum Amps	174	347
Minimum Conductor Size (Phase A, B, and C) Number per Phase		AWG or kcmil (each)	250 (1)	250 (2)
Minimum Conductor Size (Ground) Number		AWG or kcmil (each)	4 (1)	2 (2)
480 VAC Output to UPS from IAC-D (3) Phases, (1) Ground	B	Maximum Amps	75	150
Minimum Conductor Size (Phase A, B, and C) Number per Phase		AWG or kcmil (each)	2 (1)	4/0 (1)
Minimum Conductor Size (Ground) Number		AWG or kcmil (each)	8 (1)	6 (1)
480 VAC Input to IAC-D from UPS (3) Phases, (1) Ground	C	Maximum Amps	60	120
Minimum Conductor Size (Phase A, B, and C) Number per Phase		AWG or kcmil (each)	3 (1)	2/0 (1)
Minimum Conductor Size (Ground) Number		AWG or kcmil (each)	8 (1)	6 (1)
NOTE Callout letters A , B , and C map to Figure 5-6 through Figure 5-8.				

For external output power wiring recommendations, including the minimum AWG size of external wiring, see Table 3-6 for 480V/208V IAC-D and Table 3-7 for 208V/208V IAC-D. Wire sizes listed are for copper wiring only.

Table 3-6. External Output Power Wiring Recommendations for the Eaton 93PM IAC-D (480V/208V)

Basic Unit Rating	Units		Ratings		
	kW	50	100	150	200
Output Voltage	Volts	208	208	208	208
AC Output from Distribution Panel Breakers to the Critical Load (1) Line, (1) Neutral, (1) Ground	Maximum Amps	139	277	416	555
B	Wire branch circuits in accordance with branch circuit breaker manufacturer's ratings and instructions, power cable termination sizes listed in Table 3-10, and national and local electrical codes. Maximum output ratings are to be in accordance with the rating label on the IAC-D and national and local electrical codes. The total combined load is not to exceed the maximum output rating. Input is prewired to the panelboard.				
AC Output from Subfeed Breakers to the Critical Load (3) Phases, (1) Neutral, (1) Ground	Maximum Amps	139	277	416	555
B	Wire subfeed circuits in accordance with subfeed circuit breaker manufacturer's ratings, selected trip rating and instructions, power cable termination sizes listed in Table 3-10, and NFPA National Electrical Code (NEC) 70 and local electrical codes. Maximum output ratings are to be in accordance with the rating label on the IAC-D and national and local electrical codes. The total combined load is not to exceed the maximum output rating. To allow for future upgrades, consider wiring adjustable subfeed breakers for maximum rated current.				
AC Output from Optional Single Subfeed Breaker to the Critical Load (3) Phases, (1) Neutral, (1) Ground	Maximum Amps	N/A	N/A	N/A	225A
B					
Minimum Conductor Size (Phase A, B, and C) Number per Phase	AWG or kcmil (each)	N/A	N/A	3/0 (2)	3/0 (2)
Minimum Conductor Size (Neutral) Number	AWG or kcmil (each)	N/A	N/A	300 (2)	300 (2)
Minimum Conductor Size (Ground) Number	AWG or kcmil (each)	N/A	N/A	6 (1)	6 (1)
AC Output from Output Breaker to the Critical Load (3) Phases, (1) Neutral, (1) Ground	Maximum Amps	139	277	416	555
B					
Minimum Conductor Size (Phase A, B, and C) Number per Phase	AWG or kcmil (each)	250 (1)	250 (2)	250 (3)	250 (4)
Minimum Conductor Size (Neutral) Number	AWG or kcmil (each)	4/0 (2)	2/0 (4)	500 (3)	500 (4)
Minimum Conductor Size (Ground) Number	AWG or kcmil (each)	3 (1)	3 (1)	1 (1)	3 (1)
Bonding Ground	AWG or kcmil (each)	8 (1)	6 (1)	4 (1)	1 (1)

NOTE Callout letter **B** maps to Figure 5-1 through Figure 5-5.

Table 3-7. External Output Power Wiring Recommendations for the Eaton 93PM IAC-D (208V/208V)

	Units	Ratings	
Basic Unit Rating	kW	50	100
Input/Output Voltage	Volts	208/208	208/208
AC Output from Distribution Panel Breakers to the Critical Load (1) Line, (1) Neutral, (1) Ground	Maximum Amps	139	277
D	Wire branch circuits in accordance with branch circuit breaker manufacturer's ratings and instructions, power cable termination sizes listed in Table 3-10, and national and local electrical codes. Maximum output ratings are to be in accordance with the rating label on the IAC-D and national and local electrical codes. The total combined load is not to exceed the maximum output rating. Input is prewired to the panelboard.		
AC Output from Subfeed Breakers to the Critical Load (3) Phases, (1) Neutral, (1) Ground	Maximum Amps	139	277
D	Wire subfeed circuits in accordance with subfeed circuit breaker manufacturer's ratings, selected trip rating and instructions, power cable termination sizes listed in Table 3-10, and NFPA National Electrical Code (NEC) 70 and local electrical codes. Maximum output ratings are to be in accordance with the rating label on the IAC-D and national and local electrical codes. The total combined load is not to exceed the maximum output rating. To allow for future upgrades, consider wiring adjustable subfeed breakers for maximum rated current.		
AC Output from Output Breaker to the Critical Load (3) Phases, (1) Neutral, (1) Ground	Maximum Amps	139	277
D			
Minimum Conductor Size (Phase A, B, and C) Number per Phase	AWG or kcmil (each)	250 (1)	250 (2)
Minimum Conductor Size (Neutral) Number	AWG or kcmil (each)	4/0 (2)	2/0 (4)
Minimum Conductor Size (Ground) Number	AWG or kcmil (each)	3 (1)	3 (1)
Bonding Ground	AWG or kcmil (each)	8 (1)	6 (1)
NOTE Callout letter D maps to Figure 5-6 through Figure 5-8.			

The power wiring terminals are pressure terminations, UL and CSA rated or 2-hole bus bar mountings for standard NEMA 2-hole barrel lugs. See Table 3-8 for 480V/208V IAC-D external input power cable terminations or Table 3-9 for 208V/208V IAC-D external input/output power cable terminations, and Table 3-10 for external output power cable terminations. See Table 3-11 for supplied external wiring terminal hardware and Table 3-12 for recommended installation parts and tools not supplied by Eaton.

Figure 4-4 and Figure 4-5 show the 480V/208V IAC-D input power terminal locations and detail. Figure 4-6 and Figure 4-8 show the 208V/208V IAC-D input/output power terminal locations and detail.

Figure 4-10 through Figure 4-16 and Figure 4-18 through Figure 4-21 show the IAC-D output power terminal locations and detail.

Table 3-8. External Input Power Cable Terminations for the Eaton 93PM IAC-D (480V/208V)

Terminal Function	kW Rating	Terminal	Function	Number and Size of Pressure Termination (AWG or kcmil)	Tightening Torque Nm (lb in)	Type and Size Screw	
AC Input to IAC-D UPS Output Breaker	50	UOB-1	Phase A	1 – #14-1/0	5.6 (50)	5/16" Hex	
		UOB-3	Phase B	1 – #14-1/0	5.6 (50)	5/16" Hex	
		UOB-5	Phase C	1 – #14-1/0	5.6 (50)	5/16" Hex	
	100	UOB-1	Phase A	1 – #4-350	20 (177)	5/16" Hex	
		UOB-3	Phase B	1 – #4-350	20 (177)	5/16" Hex	
		UOB-5	Phase C	1 – #4-350	20 (177)	5/16" Hex	
	150	UOB-1	Phase A	2 – 2/0-250 or 1 – 2/0-500	31 (275)	5/16" Hex	
		UOB-3	Phase B	2 – 2/0-250 or 1 – 2/0-500	31 (275)	5/16" Hex	
		UOB-5	Phase C	2 – 2/0-250 or 1 – 2/0-500	31 (275)	5/16" Hex	
	200	UOB-1	Phase A	2 – 2/0-250 or 1 – 2/0-500	31 (275)	5/16" Hex	
		UOB-3	Phase B	2 – 2/0-250 or 1 – 2/0-500	31 (275)	5/16" Hex	
		UOB-5	Phase C	2 – 2/0-250 or 1 – 2/0-500	31 (275)	5/16" Hex	
	Customer Ground	—	G	Ground	1 – #14-1/0	5.1 (45)	Slotted
	Inter-Cabinet Bonding	—	G	Bonding	1 – #14-1/0	5.1 (45)	Slotted

Table 3-9. External Input Power Cable Terminations for the Eaton 93PM IAC-D (208V/208V)

Terminal Function	kW Rating	Terminal	Function	Number and Size of Pressure Termination (AWG or kcmil)	Tightening Torque Nm (lb in)	Type and Size Screw
208 VAC Input to IAC-D from Utility Source	50	A	Phase A	2 – #6–300	31 (275)	5/16" Hex
		B	Phase B	2 – #6–300	31 (275)	5/16" Hex
		C	Phase C	2 – #6–300	31 (275)	5/16" Hex
480 VAC Output to UPS from IAC-D UPS Input Breaker	50	UIB-2	Phase A	1 – #14-1/0	5.6 (50)	5/16" Hex
		UIB-4	Phase B	1 – #14-1/0	5.6 (50)	5/16" Hex
		UIB-6	Phase C	1 – #14-1/0	5.6 (50)	5/16" Hex
480 VAC Input to IAC-D from UPS	50	A	Phase A	1 – #6-500	56.5 (500)	5/16" Hex
		B	Phase B	1 – #6-500	56.5 (500)	5/16" Hex
		C	Phase C	1 – #6-500	56.5 (500)	5/16" Hex
208 VAC Input to IAC-D from Utility Source	100	A	Phase A	2 – #6–300	31 (275)	5/16" Hex
		B	Phase B	2 – #6–300	31 (275)	5/16" Hex
		C	Phase C	2 – #6–300	31 (275)	5/16" Hex
480 VAC Output to UPS from IAC-D UPS Input Breaker	100	UIB-2	Phase A	1 – #4-4/0	5.6 (50)	5/16" Hex
		UIB-4	Phase B	1 – #4-4/0	5.6 (50)	5/16" Hex
		UIB-6	Phase C	1 – #4-4/0	5.6 (50)	5/16" Hex
480 VAC Input to IAC-D from UPS	100	A	Phase A	1 – #6-500	56.5 (500)	5/16" Hex
		B	Phase B	1 – #6-500	56.5 (500)	5/16" Hex
		C	Phase C	1 – #6-500	56.5 (500)	5/16" Hex
Customer Ground	—	G	Ground	2 – #14-1/0	5.1 (45)	Slotted
Inter-Cabinet Bonding	—	G	Bonding	2 – #14-1/0	5.1 (45)	Slotted

Table 3-10. External Critical Load Output Power Cable Terminations for the Eaton 93PM IAC-D

Terminal Function	Breaker Rating	Terminal	Function	Number and Size of Pressure Termination (AWG or kcmil)	Tightening Torque Nm (lb in)	Type and Size Screw	
AC Output from Distribution Panel Breakers to Critical Load	N/A	N	Neutral	64 – #6–#14	#6–#8: 2.8 (25) #10–#14: 1.7 (15)	Slotted	
				22 – 1/0	#4–#6: 5.0 (45) #8: 4.5 (40) #10–#14: 4.0 (35)		
	N/A	G	Ground	32 – #6–#14	#6–#8: 2.8 (25) #10–#14: 1.7 (15)	Slotted	
				11 – 1/0	#4–#6: 5.0 (45) #8: 4.5 (40) #10–#14: 4.0 (35)		
	AC Output from Subfeed Breaker Terminal Block to Critical Load	N/A	A	Phase A	1 – #4–350	20 (177)	1/2" Hex
			B	Phase B	1 – #4–350	20 (177)	1/2" Hex
C			Phase C	1 – #4–350	20 (177)	1/2" Hex	
N			Neutral	2 – #6–300	31 (275)	5/16" Hex	
G			Ground	10 – #14–1/0	5.6 (50)	Slotted	
AC Output from Optional Single Subfeed Breaker Terminal Block to Critical Load (150 kW and 200 kW only)	N/A	A	Phase A	2 – #6–300	31 (275)	5/16" Hex	
		B	Phase B	2 – #6–300	31 (275)	5/16" Hex	
		C	Phase C	2 – #6–300	31 (275)	5/16" Hex	
		N	Neutral	2 – #6–300	31 (275)	5/16" Hex	
		G	Ground	2 – #14–1/0	5.6 (50)	Slotted	
AC Output from Output Breaker to Critical Load	"K" Frame 175A (50 kW IAC-D)	XOB-2	Phase A	1 – #3–350	31 (275)	5/16" Hex	
		XOB-4	Phase B	1 – #3–350	31 (275)	5/16" Hex	
		XOB-6	Phase C	1 – #3–350	31 (275)	5/16" Hex	
		N	Neutral	4 – #6–300	31 (275)	5/16" Hex	
	"LG" Frame 350A (100 kW IAC-D)	XOB-2	Phase A	2 – #2–500	42 (372)	5/16" Hex	
		XOB-4	Phase B	2 – #2–500	42 (372)	5/16" Hex	
		XOB-6	Phase C	2 – #2–500	42 (372)	5/16" Hex	
		N	Neutral	4 – #6–300	31 (275)	5/16" Hex	
	"LG" Frame 600A (150 kW IAC-D)	XOB-A	Phase A	4 – 2 bolt mounting	35 (310)	M12 Hex	
		XOB-B	Phase B	4 – 2 bolt mounting	35 (310)	M12 Hex	
		XOB-C	Phase C	4 – 2 bolt mounting	35 (310)	M12 Hex	
		N	Neutral	4 – 2 bolt mounting	35 (310)	M12 Hex	
		"MD" Frame 700A (200 kW IAC-D)	XOB-A	Phase A	4 – 2 bolt mounting	35 (310)	M12 Hex
			XOB-B	Phase B	4 – 2 bolt mounting	35 (310)	M12 Hex
			XOB-C	Phase C	4 – 2 bolt mounting	35 (310)	M12 Hex
			N	Neutral	4 – 2 bolt mounting	35 (310)	M12 Hex
Customer Ground		G	Ground	10 – #14–1/0	5.6 (50)	Slotted	

Table 3-11. Supplied External Wiring Terminal Hardware Kit

Part	Size	Quantity	Terminal Used On	Eaton Part Number
Bolt, Hex Head, Grade 5	M12 x 40mm	16	Phase and Neutral Output to Critical Load	180190078-112
Washer, Flat	M12	32	Phase and Neutral Output to Critical Load	180500036-120
Washer, Conical Spring	M12	16	Phase and Neutral Output to Critical Load	180500037-120
Nut, Hex	M12	16	Phase and Neutral Output to Critical Load	180200001-07

Table 3-12. Recommended Installation Parts and Tools (Not Supplied by Eaton)

Part	Size	Quantity	Manufacturer	Part Number	Notes
Long Barrel 2-Hole Lug	2/0 AWG	As Required	Thomas & Betts	54862BE	Copper wire only
	3/0 AWG			54864BE	
	4/0 AWG			54866BE	
	250 MCM			54868BE	
	300 MCM			54870BE	
	350 MCM			54872BE	
	400 MCM			54874BE	
	500 MCM	54876BE			
Manual Hydraulic Crimp Tool	14 Ton	1		TBM14M	
Die Set	N/A	1		15506	

External 208 Vac input overcurrent protection and disconnect are not provided by the 208V/208V IAC-D model, but are required by codes. Overcurrent protection and disconnect are to be supplied by the customer. Refer to Table 3-5 for wiring requirements.

Table 3-13 lists the recommended rating for the 208 Vac input circuit breaker. Maximum 50 kW 208V/208V IAC-D input current is 174A and maximum 100 kW 208V/208V IAC-D input current is 347A.

Table 3-13. Recommended 208 Vac Input Circuit Breaker Rating

IAC-D Model	IAC-D Rating	Input Rating	
		Load Rating	208V
Eaton 93PM 50 kW IAC-D (208V/208V)	50 kW	80% Rated	225A
		100% Rated	175A
Eaton 93PM 100 kW IAC-D (208V/208V)	100 kW	80% Rated	450A
		100% Rated	350A

 **CAUTION**

To reduce the risk of fire, connect only to a circuit provided with maximum input circuit breaker current ratings from Table 3-13 in accordance with the NEC, ANSI/NFPA 70.

3.3 Inspecting and Unpacking the IAC-D

The cabinet is shipped bolted to a wooden pallet and covered with outer protective packaging material (see Figure 3-7).

NOTE  Startup and operational checks must be performed by an authorized Eaton Customer Service Engineer, or the warranty terms specified on page W-1 become void. This service is offered as part of the sales contract for the UPS. Contact an Eaton service representative in advance (usually a two-week notice is required) to reserve a preferred startup date.

WARNING 

The IAC-D is heavy (see Table 3-2). If unpacking and unloading instructions are not closely followed, the cabinet may tip and cause serious injury.

1. Carefully inspect the outer packaging for evidence of damage during transit.
-

CAUTION 

Do not install a damaged cabinet. Report any damage to the carrier and contact an Eaton service representative immediately.

NOTE  For the following step, verify that the forklift or pallet jack is rated to handle the weight of the cabinet (see Table 3-2).

2. Use a forklift or pallet jack to move the packaged cabinet to the installation site, or as close as possible, before unpacking. If possible, move the cabinet using the pallet. Insert the forklift or pallet jack forks between the supports on the bottom of the pallet (see Figure 3-3 for the IAC-D cabinet center of gravity measurements).
-

CAUTION 

Do not tilt the IAC-D more than 10° from vertical or the cabinet may tip over.

3. Set the pallet on a firm, level surface, allowing a minimum clearance of 3m (10 ft) on each side for removing the cabinet from the pallet.
 4. Remove the protective packaging material from the cabinet and recycle in a responsible manner. Retain the parts kit box packed inside the cabinet.
 5. Inspect the contents for any evidence of physical damage, and compare each item with the Bill of Lading. If damage has occurred or shortages are evident, contact an Eaton service representative immediately to determine the extent of the damage and its impact on further installation.
-

NOTE  While waiting for installation, protect the unpacked cabinet from moisture, dust, and other harmful contaminants. Failure to store and protect the IAC-D properly may void your warranty.

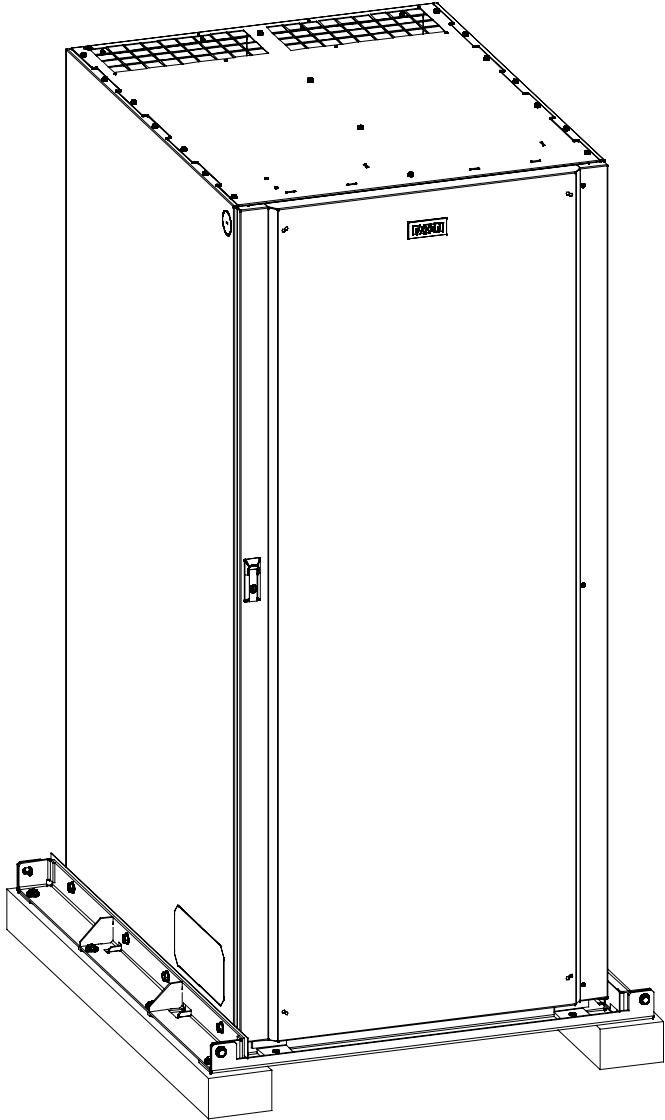

Figure 3-7. Eaton 93PM IAC-D as Shipped on Metal and Wood Pallet

Chapter 4 Installation

4.1 Preliminary Installation Information

 **WARNING**

Installation should be performed only by qualified personnel.

When installing the Eaton 93PM Integrated Accessory Cabinet-Distribution (IAC-D):

- See Chapter 3 for cabinet dimensions, equipment weight, wiring and terminal data, and installation notes.
- Do not tilt the IAC-D more than 10° vertical or the cabinet may tip over.

4.2 Unloading the IAC-D Cabinet from the Pallet

 **DANGER**

RISK OF INSTABILITY. Do not remove any internal panels until the cabinet is removed from and lowered from the pallet.

 **WARNING**

The IAC-D is heavy (see Table 3-2). If unpacking and unloading instructions are not closely followed, the cabinet may tip and cause serious injury.

 **CAUTION**

- Do not tilt the IAC-D more than 10° from vertical or the cabinet may tip over.
- Lift the cabinets only with a forklift or pallet jack or damage may occur.

 **NOTE** Before performing the IAC-D unloading, verify that the forklift or pallet jack is rated to handle the weight of the cabinet (see Table 3-2 for cabinet weight).

The IAC-D is bolted to a pallet consisting of two metal angle supports and two flat supports secured to two wood supports.

1. If not already accomplished, use a forklift or pallet jack to move the IAC-D to the installation area, or as close as possible, before unloading from the pallet. Insert the forklift or pallet jack forks between the supports on the bottom of the pallet (see Figure 3-3 for the IAC-D cabinet center of gravity measurements).
2. Open the front door (see Figure 4-1) by lifting the latch from the bottom and turning to the right (counterclockwise) and swing the door open.
3. Locate the four 1/2" jacking bolts from the parts bag packed inside the front door and install them in the threaded holes in the front and rear supports as shown in Figure 4-1. Place a floor protector from the parts kit underneath each jacking bolt, and screw the bolts down against them.

The floor protectors protect the floor from being marred by the jacking bolts.

4. Loosen, but do not remove, the skid mounting bolts holding the left, right, front, rear, and two center supports to the pallet skids (see Figure 4-1). **DO NOT** loosen or remove the cabinet mounting bolts or the cabinet support bolts.

Installation

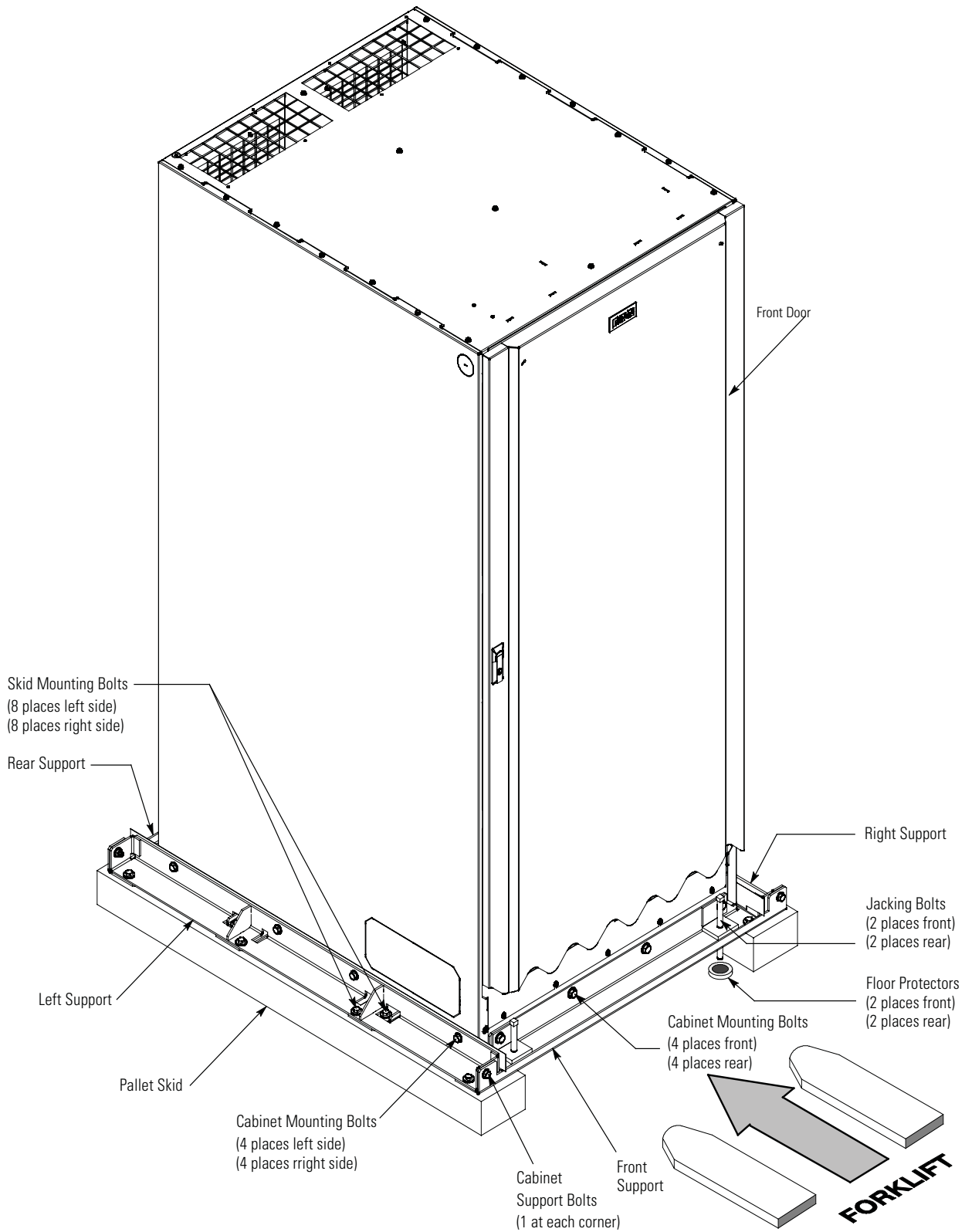

Figure 4-1. Removing the Pallet Skids and Supports – Eaton 93PM Integrated Accessory Cabinet-Distribution

 **WARNING**

RISK OF INSTABILITY. Turning the jacking bolts unevenly may cause the cabinet to become unbalanced. To prevent tipping the cabinet, raise and lower the jacking bolts evenly.

 **CAUTION**

CABINET MAY TIP. Raise the IAC-D no more than 3 mm (1/8") above the floor (just enough to allow the removal of the pallet skids).

5. Turn each jacking bolt consecutively, two full turns, until the pallet skids clear the floor by approximately 3 mm (1/8").

**NOTE**

In the following step the center supports will drop away from the cabinet and the pallet skids when the skids are removed.

6. Remove the hardware loosened in Step 4. Pull the two pallet skids out from under the left, right, front, rear, and two center supports. Recycle the pallet skids, supports, and hardware in a responsible manner.

 **CAUTION**

CABINET MAY FALL. Do not loosen the hardware attaching the front supports to the cabinet base. The cabinet must be lowered by the jacking bolts before the supports can be removed.

7. Carefully and evenly **lower the cabinet by turning each jacking bolt consecutively two full turns (maximum)** until the casters contact the floor and the cabinet is no longer supported by the jacking bolts.
8. After the IAC-D is resting on the floor, remove the jacking bolts and floor protectors. Recycle them in a responsible manner.
9. Remove the cabinet support bolts fastening the left, right, front, and rear supports together (see Figure 4-1).
10. Remove the cabinet mounting bolts holding the left, right, front, and rear supports to the cabinet base and remove the supports (see Figure 4-1).
11. If installing the cabinet permanently, retain the cabinet mounting bolts; otherwise, recycle the bolts along with the support brackets in a responsible manner.
12. Close the door and secure the latch.
13. If the leveling feet are not retracted, turn all four leveling feet until they are retracted as far into the cabinet as possible.

**NOTE**

The IAC-D may be located to either the right or left of the UPS cabinet. The recommended location is to the left of the UPS cabinet. This procedure assumes the IAC-D is located to the left of the UPS cabinet.

14. If line-up-and-match installation, remove the rectangular knockout on the bottom front side of the UPS and the IAC-D (see Figure 4-2).

 **CAUTION**

To prevent tipping when rolling the cabinet, push the cabinet from the rear whenever possible.

15. Roll the IAC-D to the line-up-and-match installation location on the left side of the UPS cabinet making sure the doors are flush with each other or to the standalone installation location.

 **NOTE** Use the leveling feet to level and lock the cabinet in place.

16. Secure the IAC-D in position by lowering the leveling feet until the cabinet is level and locked in place.
17. Locate the top splice bracket shipped with the IAC-D.
18. Remove the screws along each adjacent cabinet top panel securing the top panels. Retain the hardware for later use.
19. Install the top splice bracket between the adjacent cabinet and secure the tie strap with retained hardware.

 **NOTE** Optional front and back floor mounting brackets are available to order for permanently mounting the IAC-D.

20. If permanently mounting the IAC-D, proceed to Step 21; otherwise, continue to Step 24.
21. Locate the front and back floor mounting brackets from the optional floor mounting kit.
22. Using the cabinet mounting bolts from the kit, install the floor mounting brackets to the front and rear of the IAC-D with the angle facing outward.
23. Secure the cabinet to the floor with customer-supplied hardware.
24. Proceed to paragraph 4.3.

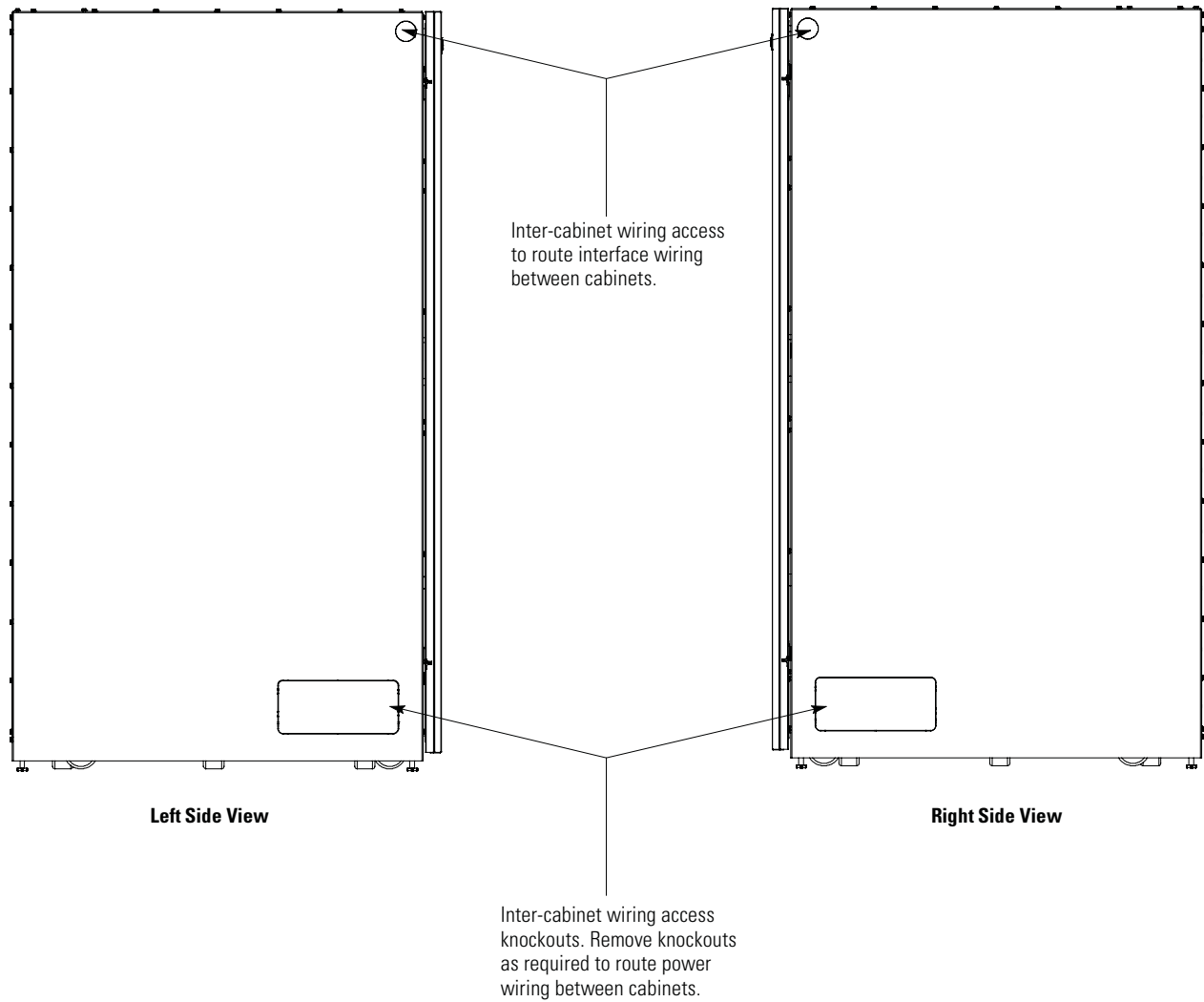

Figure 4-2. Line-Up-and-Match Wiring Access Locations

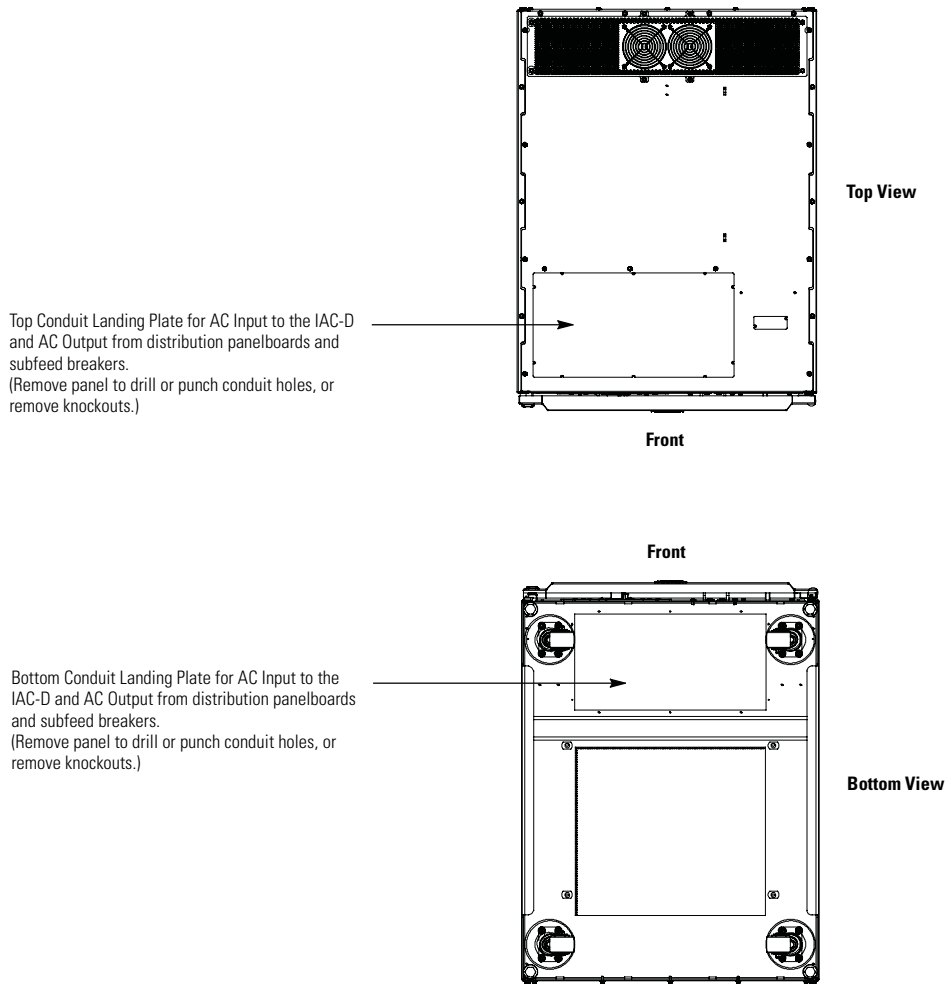

Figure 4-3. Top and Bottom Conduit Landing Wire Entry Locations

4.3 Installing IAC-D External Power Wiring

If wiring a 480V/208V IAC-D, proceed to paragraph 4.3.1; if wiring a 208V/208V IAC-D, proceed to paragraph 4.3.2.

4.3.1 Input Wiring (480V/208V)

To install wiring to connections:

NOTE 1 Input power wiring is routed through the inside bottom of the IAC-D and UPS for line-up-and-match configurations or wiring can be installed using conduit between the cabinets for standalone installations.



NOTE 2 Remove the IAC-D conduit landing plates to drill or punch conduit holes, or remove knockouts in the conduit plate (see Figure 4-3).

1. Verify the UPS system is turned off and all power sources are removed. See Chapter 6, “UPS Operating Instructions,” for shutdown instructions.
2. If not already open, open the front door (see Figure 4-1) by lifting the latch from the bottom and turning to the right (counterclockwise) and swing the door open.
3. Loosen the screws securing the inside distribution panel door and swing the door open.
4. Remove the screws securing the breaker trim plate and remove the plate. Retain trim plate and hardware for later use.
5. If wiring the IAC-D input power terminals using the inter-cabinet wiring access pass-through (line-up-and-match configurations), proceed to Step 6; if wiring the IAC-D input power terminals using the bottom entry access, proceed to Step 8; if wiring the IAC-D input power terminals using the top entry access, proceed to Step 11.
6. **Pass-through Wiring.** Route the IAC-D input cables (phase A, B, and C and Ground) from the UPS cabinet through the bottom UPS and IAC-D inter-cabinet wiring access pass-through to the IAC-D input terminals. See Figure 4-2 for IAC-D wiring access information and Figure 4-4 for IAC-D terminal locations. See paragraph 3.2.2, Table 3-4, and Table 3-8 for IAC-D wiring and termination requirements. Refer to the applicable Eaton 93PM UPS manual, listed in paragraph 1.7, for the UPS terminal locations and termination requirements.
7. Proceed to Step 13.
8. **Bottom Entry Wiring.** Remove the bottom conduit plate (see Figure 4-3) from the inside bottom of the IAC-D. Identify all conduit requirements (both input and output) and mark their location. Drill and punch all conduit holes in the bottom conduit plate prior to mounting on the IAC-D. Install the conduit plate and install all conduit runs into the plate. Pull the wiring through conduit into the wiring area.
9. Route the output cables (phase A, B, and C and Ground) from the UPS through the bottom of the cabinet to the IAC-D input terminals. See Figure 4-4 for IAC-D terminal locations. See paragraph 3.2.2, Table 3-4, and Table 3-8 for IAC-D wiring and termination requirements. Refer to the applicable Eaton 93PM UPS manual, listed in paragraph 1.7, for the UPS terminal locations and termination requirements.
10. Proceed to Step 13.
11. **Top Entry Wiring.** Remove the top conduit plate (see Figure 4-3) from the top of the IAC-D. Identify all conduit requirements (both input and output) and mark their location. Drill and punch all conduit holes in the top conduit plate prior to mounting on the sidecar. Install the conduit plate and install all conduit runs into the plate. Pull the wiring through the conduit into the wiring area.
12. Route the output cables (phase A, B, and C and Ground) from the UPS through the top of the cabinet to the IAC-D input terminals. See Figure 4-4 for IAC-D terminal locations. See paragraph 3.2.2, Table 3-4, and Table 3-8 for IAC-D wiring and termination requirements. Refer to the applicable Eaton 93PM UPS manual, listed in paragraph 1.7, for the UPS terminal locations and termination requirements.

13. Connect phase A, B, and C and Ground power wiring to the corresponding input terminals on the IAC-D.
For a detailed view of the IAC-D input terminals, see Figure 4-5.
14. Connect phase A, B, and C and Ground power wiring to the corresponding output terminals on the UPS.
15. Proceed to paragraph 4.3.3 for 50 kW and 100kW output wiring or 4.3.4 for 150 kW and 200 kW output wiring.

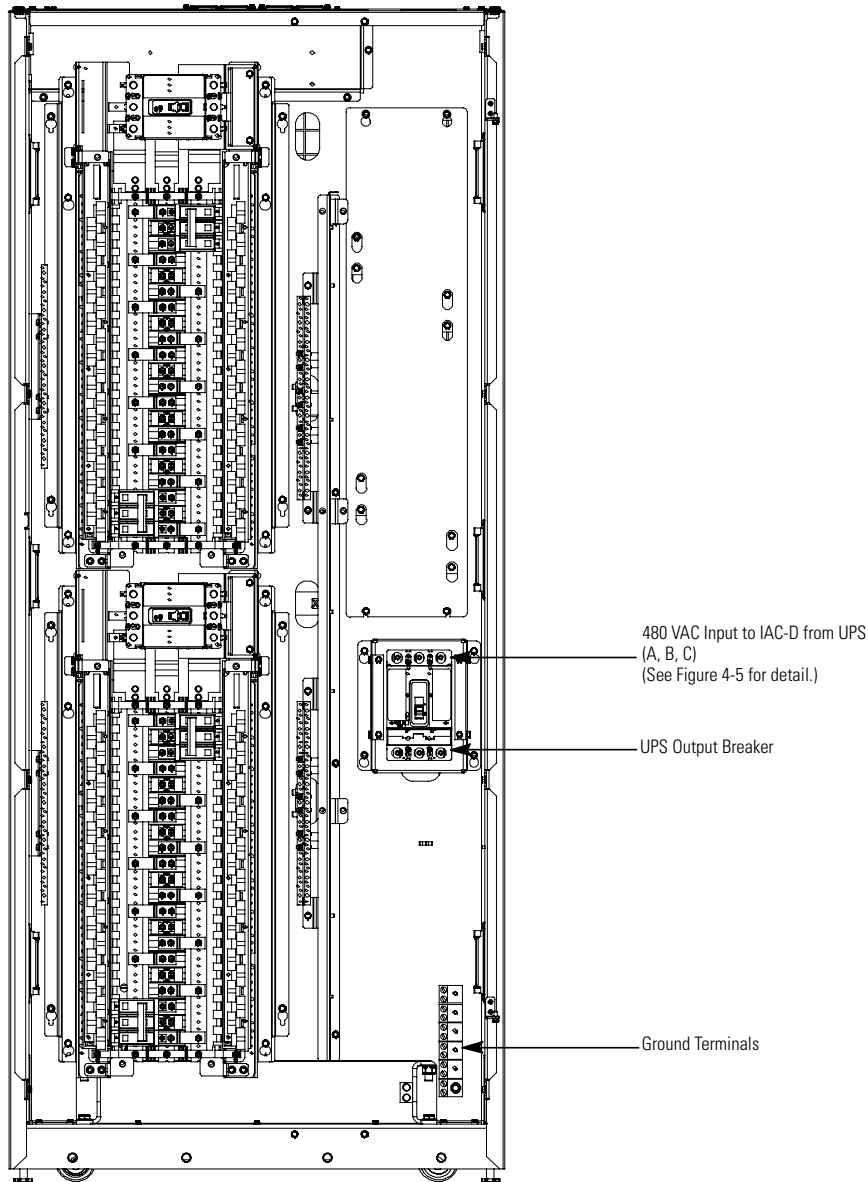

NOTE The IAC-D is shown with top and bottom panelboards. However, the input and ground terminal locations are the same for all configurations.

Figure 4-4. Input Power Terminal Locations – 480V/208V

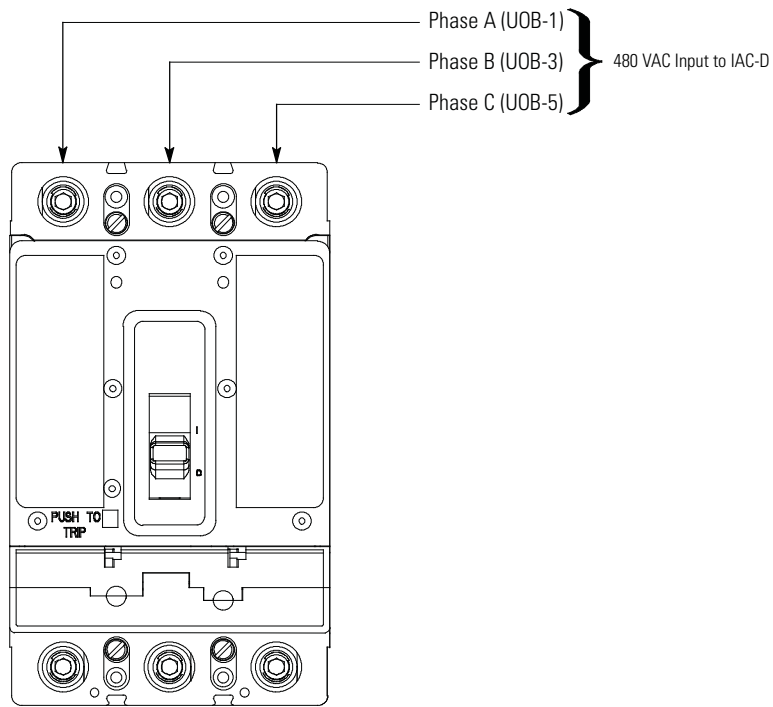

Figure 4-5. UPS Output Breaker Power Terminal Detail – 480V/208V

4.3.2 Input Wiring (208V/208V)

To install wiring to connections:

NOTE 1 Input power wiring is routed through the inside bottom of the IAC-D and UPS for line-up-and-match configurations or wiring can be installed using conduit between the cabinets for standalone installations.

NOTE 2 Remove the IAC-D conduit landing plates to drill or punch conduit holes, or remove knockouts in the conduit plate (see Figure 4-3).

NOTE 3 If installing the IAC-D with a Sidecar Integrated Accessory Cabinet-Bypass (SIAC-B) or wall mount maintenance bypass see paragraph 3.2.3.

1. Verify the UPS system is turned off and all power sources are removed. See Chapter 6, “UPS Operating Instructions,” for shutdown instructions.
2. If not already open, open the front door (see Figure 4-1) by lifting the latch from the bottom and turning to the right (counterclockwise) and swing the door open.
3. Loosen the screws securing the inside distribution panel door and swing the door open.
4. Remove the screws securing the breaker trim plate and remove the plate. Retain trim plate and hardware for later use.
5. If wiring the IAC-D input power terminals using the inter-cabinet wiring access pass-through (line-up-and-match configurations), proceed to Step 6; if wiring the IAC-D input power terminals using the bottom entry access, proceed to Step 16; if wiring the IAC-D input power terminals using the top entry access, proceed to Step 26.
6. **Pass-through Wiring.** Remove the top or bottom conduit plate (see Figure 4-3) from the top of the IAC-D or the inside bottom of the IAC-D. Identify all conduit requirements (both input and output) and mark their location. Drill and punch all conduit holes in the top or bottom conduit plate prior to mounting on the IAC-D. Install the conduit plate and install all conduit runs into the plate. Pull the wiring through conduit into the wiring area.
7. Route the 208 VAC input cables (phase A, B, and C and Ground) from the utility source through the top or bottom of the cabinet to the IAC-D 208 VAC utility source input terminals. See Figure 4-6 for IAC-D terminal locations. See paragraph 3.2.2, Table 3-5, and Table 3-9 for IAC-D wiring and termination requirements.
8. Connect phase A, B, and C and Ground power wiring to the corresponding 208 VAC utility source input terminals on the IAC-D.

For a detailed view of the IAC-D utility source input terminals, see Figure 4-7.
9. Route the 480 VAC output cables (phase A, B, and C and Ground) from the IAC-D through the bottom IAC-D and UPS inter-cabinet wiring access pass-through to the UPS rectifier input terminals. See Figure 4-2 for IAC-D wiring access information and Figure 4-6 for IAC-D terminal locations. See paragraph 3.2.2, Table 3-5, and Table 3-9 for IAC-D wiring and termination requirements. Refer to the applicable Eaton 93PM UPS manual, listed in paragraph 1.7, for the UPS terminal locations and termination requirements.
10. Connect phase A, B, and C and Ground power wiring to the corresponding 480 VAC output terminals on the IAC-D.

For a detailed view of the IAC-D 480 VAC output terminals, see Figure 4-8.
11. Connect phase A, B, and C and Ground power wiring to the corresponding rectifier input terminals on the UPS.

12. Route the 480 VAC output cables (phase A, B, and C and Ground) from the UPS through the bottom UPS and IAC-D inter-cabinet wiring access pass-through to the IAC-D 480 VAC input terminals. See Figure 4-6 for IAC-D terminal locations. See paragraph 3.2.2, Table 3-5, and Table 3-9 for IAC-D wiring and termination requirements. Refer to the applicable Eaton 93PM UPS manual, listed in paragraph 1.7, for the UPS terminal locations and termination requirements.

13. Connect phase A, B, and C and Ground power wiring to the corresponding 480 VAC input terminals on the IAC-D.

For a detailed view of the IAC-D 480 VAC input terminals, see Figure 4-9.

14. Connect phase A, B, and C and Ground power wiring to the corresponding output terminals on the UPS
15. Proceed to Step 35.

16. **Bottom Entry Wiring.** Remove the bottom conduit plate (see Figure 4-3) from the inside bottom of the IAC-D. Identify all conduit requirements (both input and output) and mark their location. Drill and punch all conduit holes in the bottom conduit plate prior to mounting on the IAC-D. Install the conduit plate and install all conduit runs into the plate. Pull the wiring through conduit into the wiring area.

17. Route the 208 VAC input cables (phase A, B, and C and Ground) from the utility source through the bottom of the cabinet to the IAC-D 208 VAC utility source input terminals. See Figure 4-6 for IAC-D terminal locations. See paragraph 3.2.2, Table 3-5, and Table 3-9 for IAC-D wiring and termination requirements.

18. Connect phase A, B, and C and Ground power wiring to the corresponding 208 VAC utility source input terminals on the IAC-D.

For a detailed view of the IAC-D utility source input terminals, see Figure 4-7.

19. Route the 480 VAC output cables (phase A, B, and C and Ground) from the IAC-D through the bottom of the cabinet to the UPS rectifier input terminals. See Figure 4-6 for IAC-D terminal locations. See paragraph 3.2.2, Table 3-5, and Table 3-9 for IAC-D wiring and termination requirements. Refer to the applicable Eaton 93PM UPS manual, listed in paragraph 1.7, for the UPS terminal locations and termination requirements.

20. Connect phase A, B, and C and Ground power wiring to the corresponding 480 VAC output terminals on the IAC-D.

For a detailed view of the IAC-D 480 VAC output terminals, see Figure 4-8.

21. Connect phase A, B, and C and Ground power wiring to the corresponding rectifier input terminals on the UPS.

22. Route the 480 VAC output cables (phase A, B, and C and Ground) from the UPS through the bottom of the cabinet to the IAC-D 480 VAC input terminals. See Figure 4-6 for IAC-D terminal locations. See paragraph 3.2.2, Table 3-5, and Table 3-9 for IAC-D wiring and termination requirements. Refer to the applicable Eaton 93PM UPS manual, listed in paragraph 1.7, for the UPS terminal locations and termination requirements.

23. Connect phase A, B, and C and Ground power wiring to the corresponding 480 VAC input terminals on the IAC-D.

For a detailed view of the IAC-D 480 VAC input terminals, see Figure 4-9.

24. Connect phase A, B, and C and Ground power wiring to the corresponding output terminals on the UPS.
25. Proceed to Step 35.

26. **Top Entry Wiring.** Remove the top conduit plate (see Figure 4-3) from the top of the IAC-D. Identify all conduit requirements (both input and output) and mark their location. Drill and punch all conduit holes in the top conduit plate prior to mounting on the sidecar. Install the conduit plate and install all conduit runs into the plate. Pull the wiring through the conduit into the wiring area.

27. Route the 208 VAC input cables (phase A, B, and C and Ground) from the utility source through the top of the cabinet to the IAC-D 208 VAC utility source input terminals. See Figure 4-6 for IAC-D terminal locations. See paragraph 3.2.2, Table 3-5, and Table 3-9 for IAC-D wiring and termination requirements.

28. Connect phase A, B, and C and Ground power wiring to the corresponding 208 VAC utility source input terminals on the IAC-D.

For a detailed view of the IAC-D utility source input terminals, see Figure 4-7.

29. Route the 480 VAC output cables (phase A, B, and C and Ground) from the IAC-D through the top of the cabinet to the UPS rectifier input terminals. See Figure 4-6 for IAC-D terminal locations. See paragraph 3.2.2, Table 3-5, and Table 3-9 for IAC-D wiring and termination requirements. Refer to the applicable Eaton 93PM UPS manual, listed in paragraph 1.7, for the UPS terminal locations and termination requirements.

30. Connect phase A, B, and C and Ground power wiring to the corresponding 480 VAC output terminals on the IAC-D.

For a detailed view of the IAC-D 480 VAC output terminals, see Figure 4-8.

31. Connect phase A, B, and C and Ground power wiring to the corresponding rectifier input terminals on the UPS.

32. Route the 480 VAC output cables (phase A, B, and C and Ground) from the UPS through the top of the cabinet to the IAC-D 480 VAC input terminals. See Figure 4-6 for IAC-D terminal locations. See paragraph 3.2.2, Table 3-5, and Table 3-9 for IAC-D wiring and termination requirements. Refer to the applicable Eaton 93PM UPS manual, listed in paragraph 1.7, for the UPS terminal locations and termination requirements.

33. Connect phase A, B, and C and Ground power wiring to the corresponding 480 VAC input terminals on the IAC-D.

For a detailed view of the IAC-D 480 VAC input terminals, see Figure 4-9.

34. Connect phase A, B, and C and Ground power wiring to the corresponding output terminals on the UPS.

35. Proceed to paragraph 4.3.3 for 50 kW and 100kW output wiring.

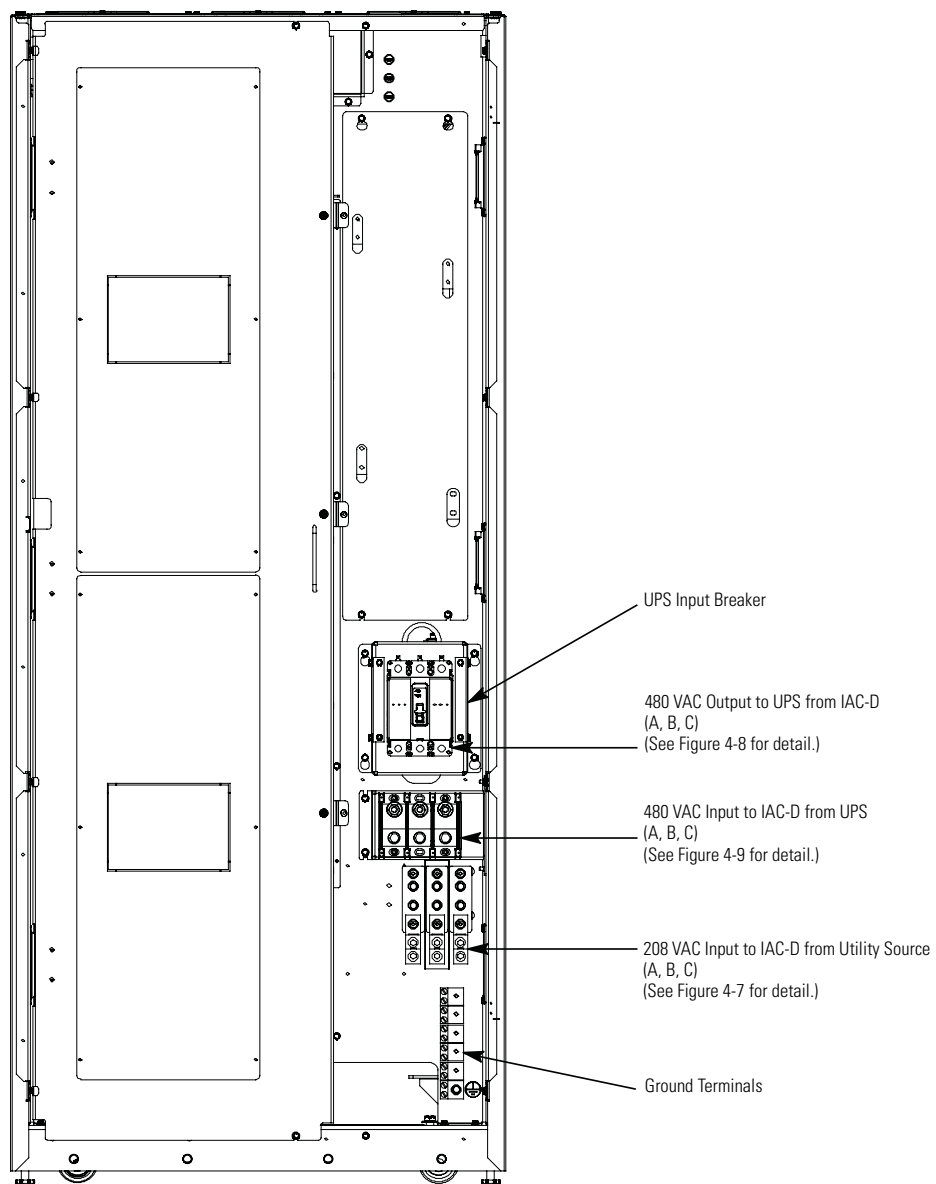

NOTE The IAC-D is shown without output options. See Figure 4-11 through Figure 4-16 for output options.

Figure 4-6. Input Power Terminal Locations – 208V/208V

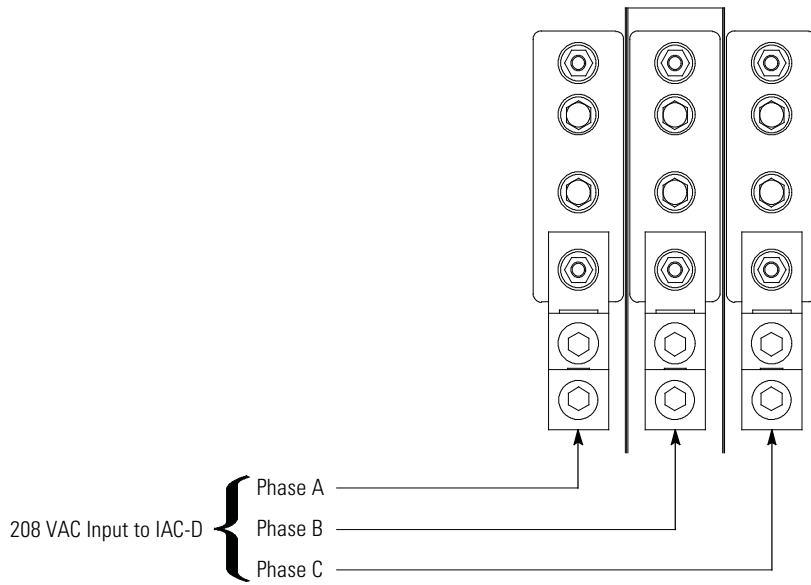

Figure 4-7. 208 VAC Input to IAC-D from Utility Source Terminal Detail – 208V/208V

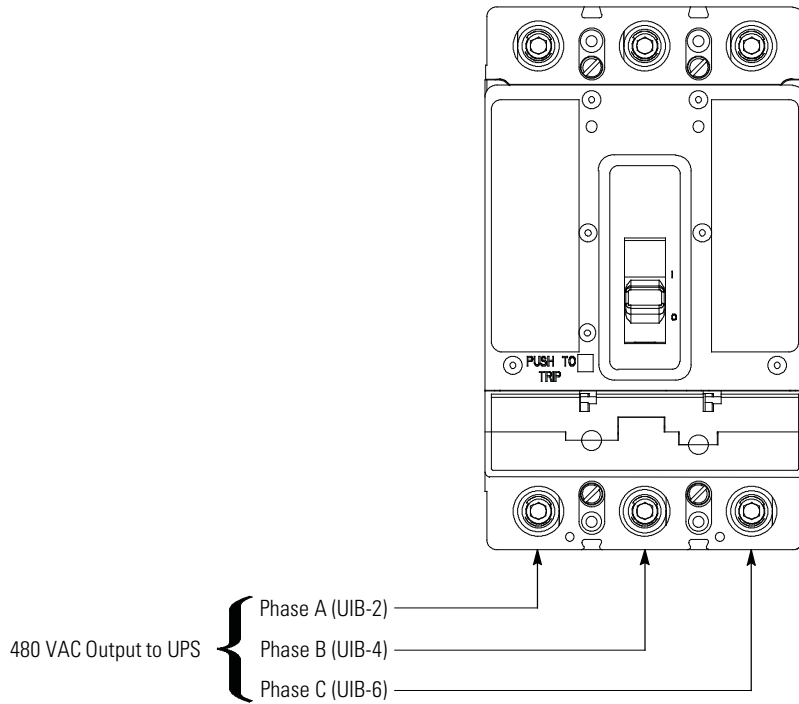

Figure 4-8. UPS Input Breaker Power Terminal Detail – 208V/208V

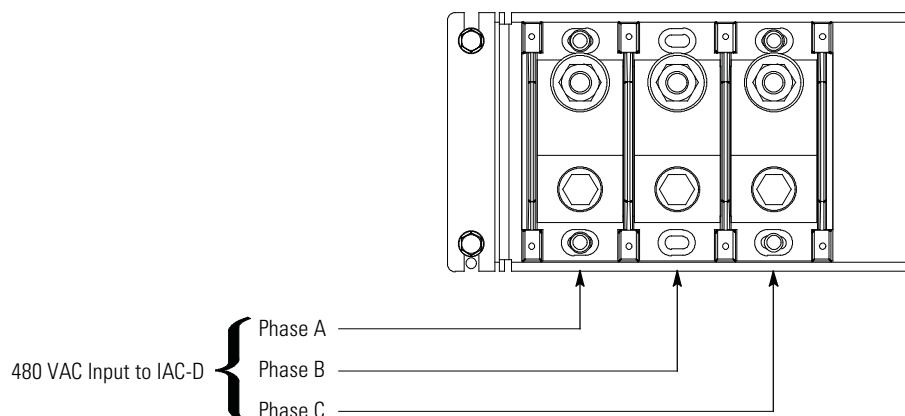

Figure 4-9. 480 VAC Input to IAC-D from UPS Terminal Detail – 208V/208V

4.3.3 50 kW and 100 kW Output Wiring

To install wiring to connections:

1. If not already open, open the front door (see Figure 4-1) by lifting the latch from the bottom and turning to the right (counterclockwise) and swing the door open.
2. Loosen the screws securing the inside distribution panel door and swing the door open.
3. Loosen the screws securing the inside trim plate(s) and remove the plate(s). Retain trim plate(s) and hardware for later use.
4. If wiring an IAC-D with distribution panels, continue to Step 5; if wiring an IAC-D with subfeed breakers or an output breaker, skip to Step 8.
5. Install customer-supplied branch circuit breakers into the distribution panel (see Figure 4-10 or Figure 4-11). Use Cutler-Hammer bolt-on type BAB or QBHW breakers.



NOTE When wiring branch circuits, begin adding conduits at the back of the bottom or top conduit landing plates to simplify future circuit additions.

6. Route output cables to the branch circuit breakers and wire the branch circuits according to the branch circuit breaker manufacturer's ratings and instructions, and national and local electrical codes (input is prewired to the panelboard). See Figure 4-10 or Figure 4-11 for neutral and ground terminal locations. See paragraph 3.2.2, Table 3-6 or Table 3-7, and Table 3-10 for IAC-D wiring and termination requirements.
7. If wiring an IAC-D with subfeed breakers or an output breaker, continue to Step 8; otherwise, skip to Step 11.



NOTE When wiring subfeed branch circuits, begin adding conduits at the back of the bottom or top conduit landing plates to simplify future circuit additions.

8. Route output cables from subfeed breaker terminal blocks or output breaker to the critical load. See Figure 4-11, Figure 4-13, or Figure 4-15 for IAC-D output, neutral, and ground terminal locations. See paragraph 3.2.2, Table 3-6 or Table 3-7, and Table 3-10 for IAC-D wiring and termination requirements.

Installation

9. Connect phase A, B, and C, Neutral, and Ground power wiring to the subfeed breaker terminal blocks or output breaker and the critical load.

For a detailed view of the IAC-D output terminals, see Figure 4-12, Figure 4-14, or Figure 4-16.

10. If adjustable subfeed breakers are installed, proceed to paragraph 4.4 to adjust current trip settings; otherwise, proceed to Step 11.
11. Reinstall the inside trim plate removed in Step 3.
12. Close the inside door and secure with screws.
13. Close the outside door and secure the latch.
14. After the IAC-D is installed and wired, return to the applicable Eaton 93PM UPS installation and operation manual listed in paragraph 1.7 to complete the UPS wiring.

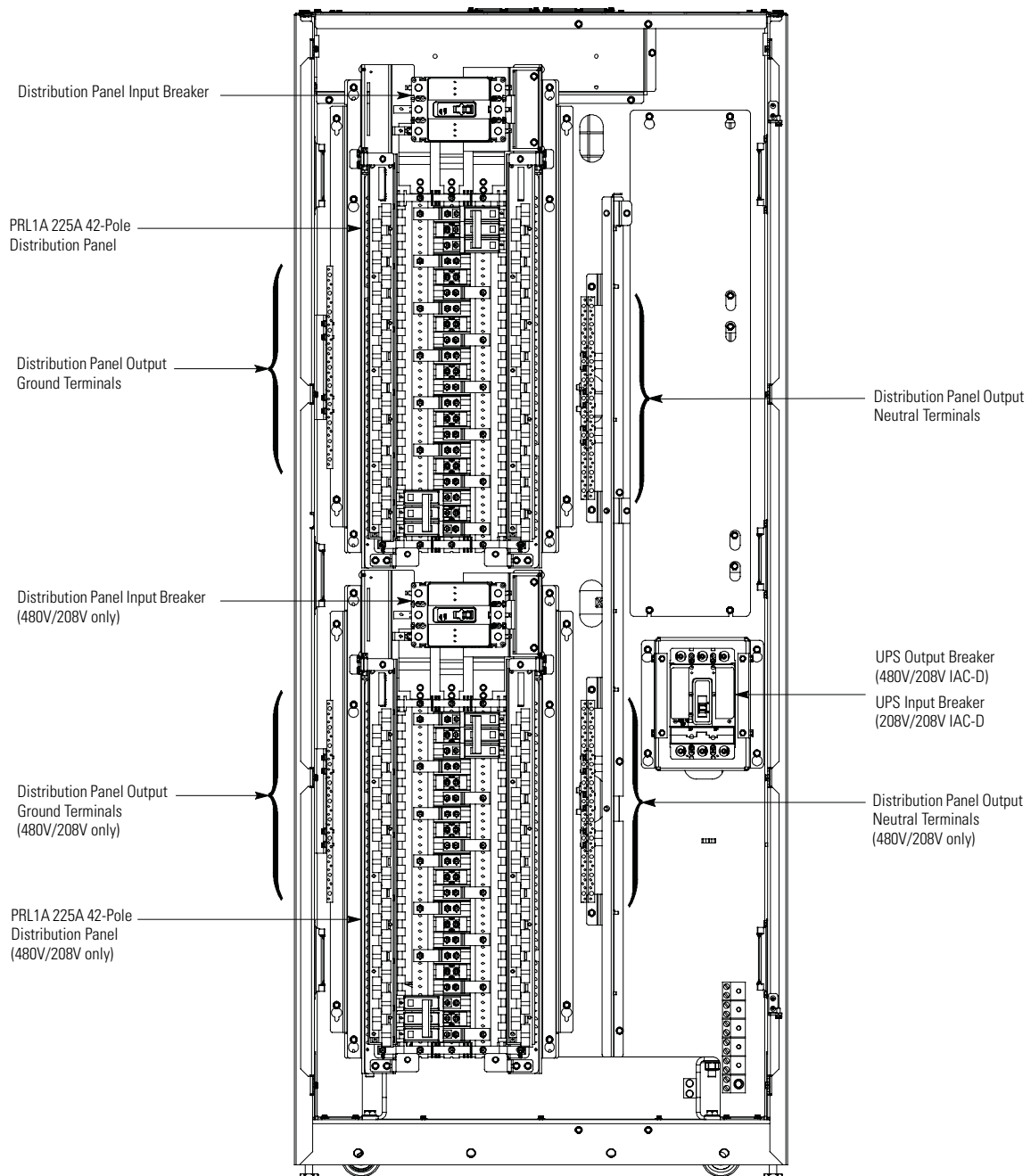

NOTE 1 The IAC-D is shown with both top and bottom panelboards. However, the installed configuration may contain only a top or bottom panelboard or a combination of one panelboard and up to three subfeed breakers.

NOTE 2 The bottom panelboard is not available with the 208V/208V IAC-D.

Figure 4-10. Distribution Panel Output Power Terminal Locations – 50 kW and 100 kW

Installation

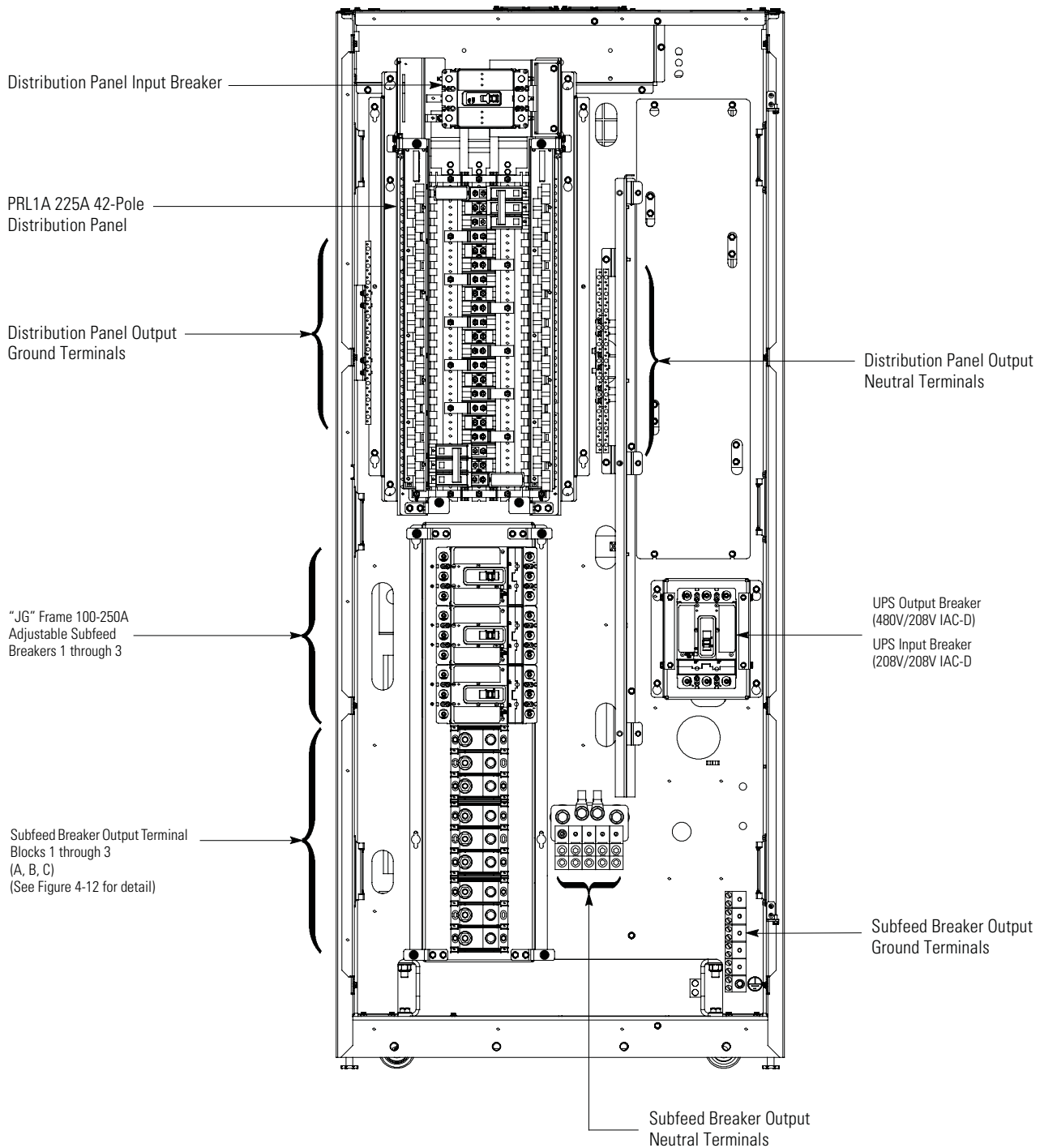

NOTE The IAC-D is shown with a top panelboard and three subfeed breakers. However, the installed configuration may contain one to three subfeed breakers.

Figure 4-11. Top Distribution Panel and Bottom Subfeed Breaker Output Power Terminal Locations

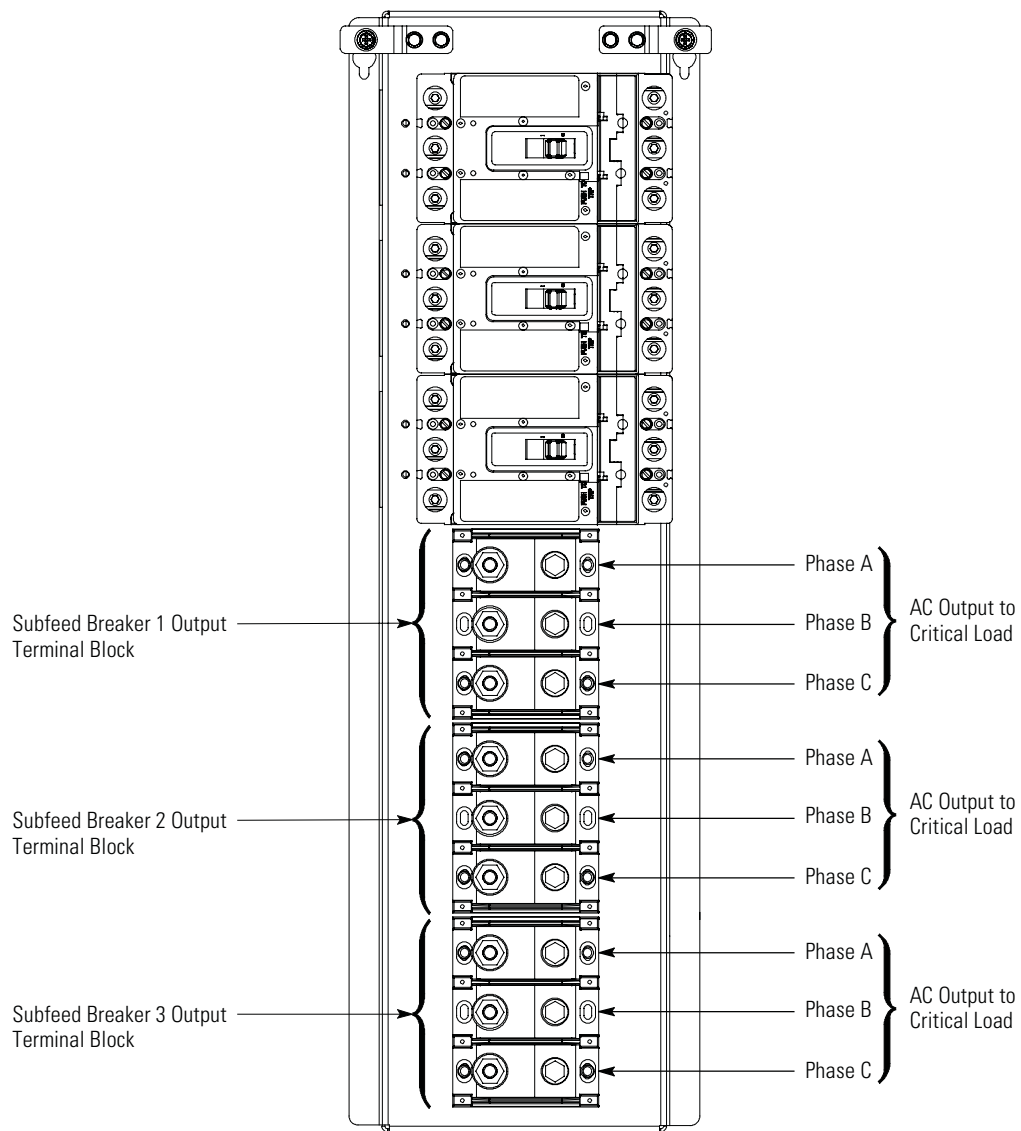
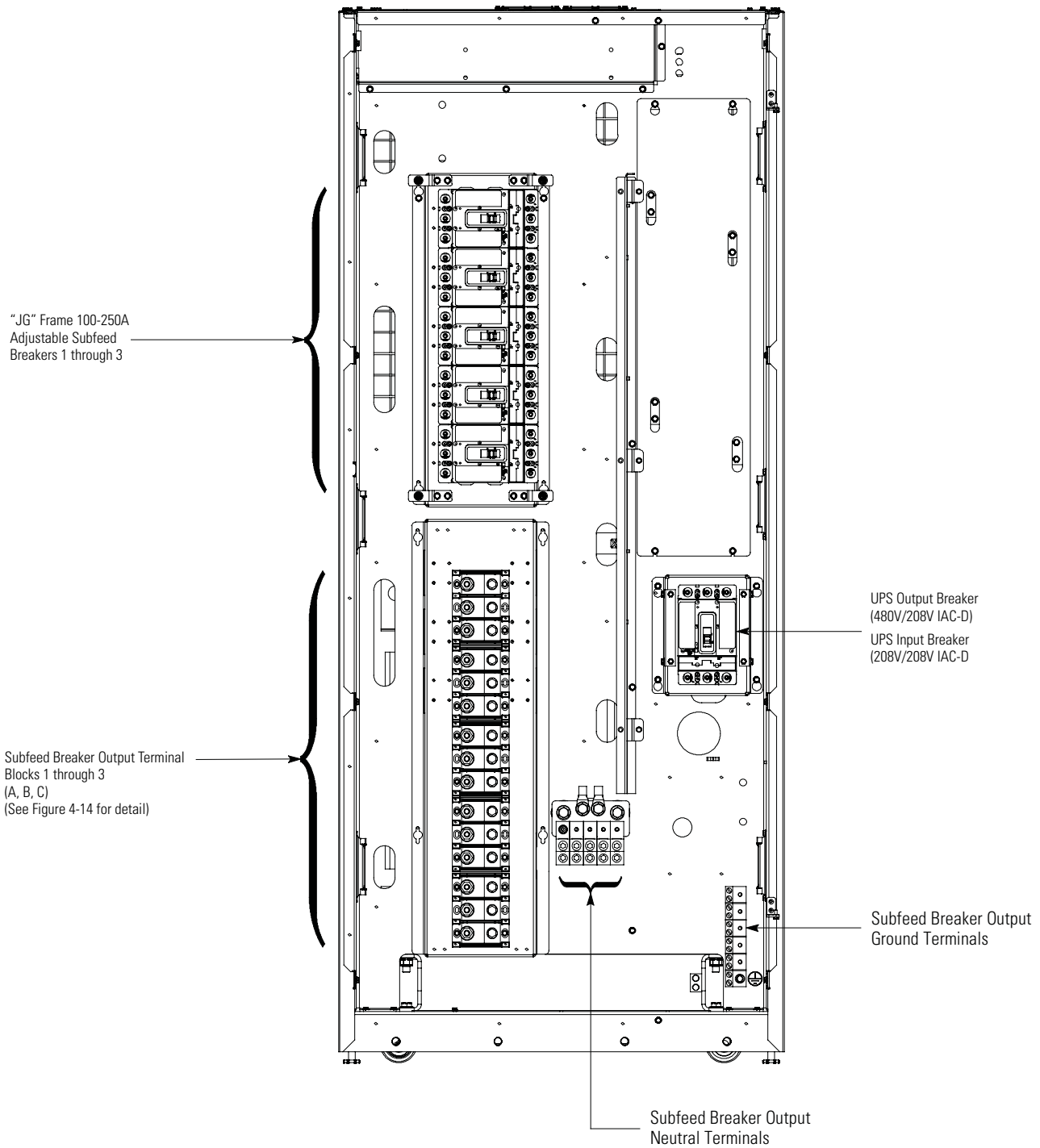

Figure 4-12. Bottom Subfeed Breaker Output Power Terminal Detail

Installation



NOTE The IAC-D is shown with five subfeed breakers. However, the installed configuration may contain one to five subfeed breakers.

Figure 4-13. Subfeed Breaker Output Power Terminal Locations

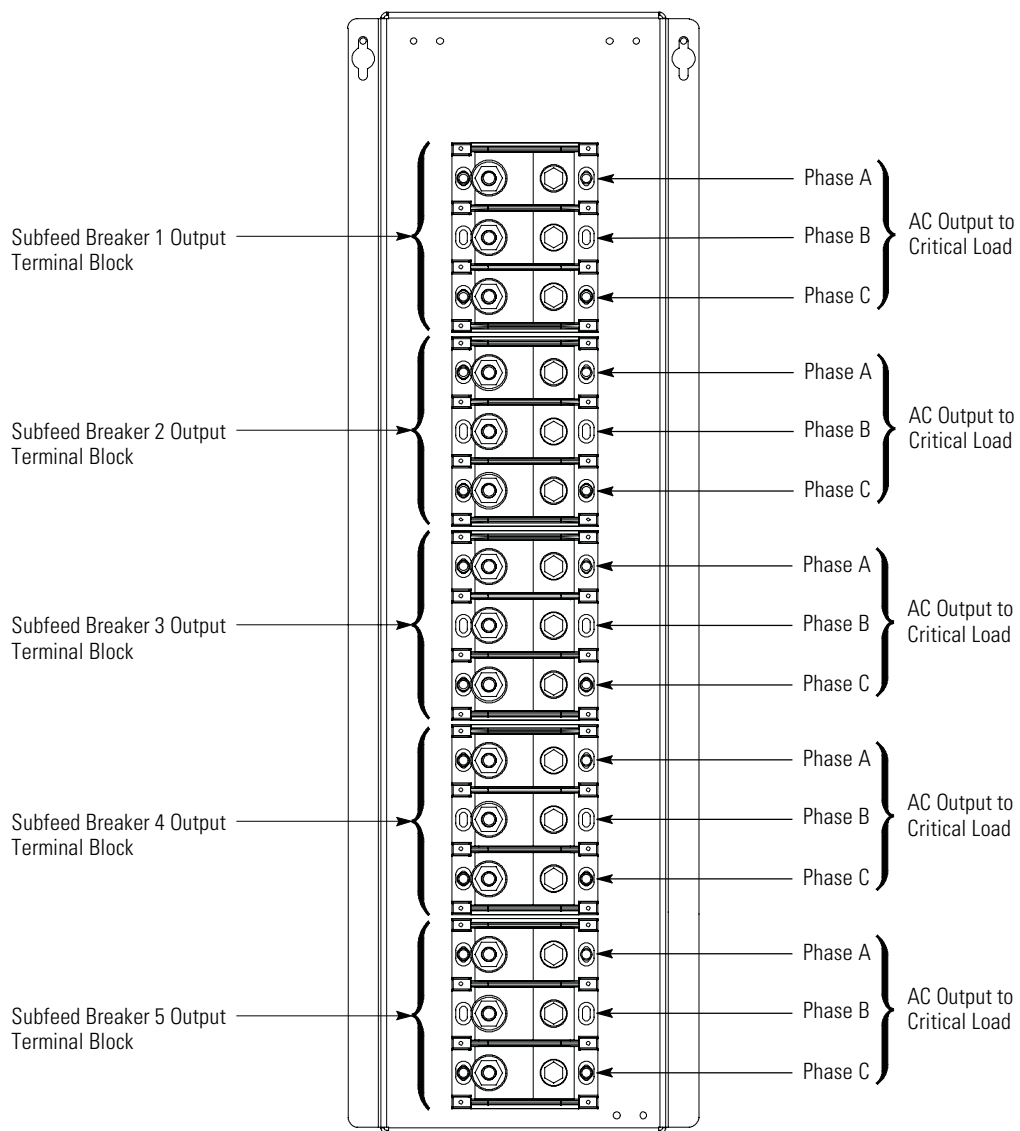

Figure 4-14. Subfeed Breaker Output Power Terminal Detail

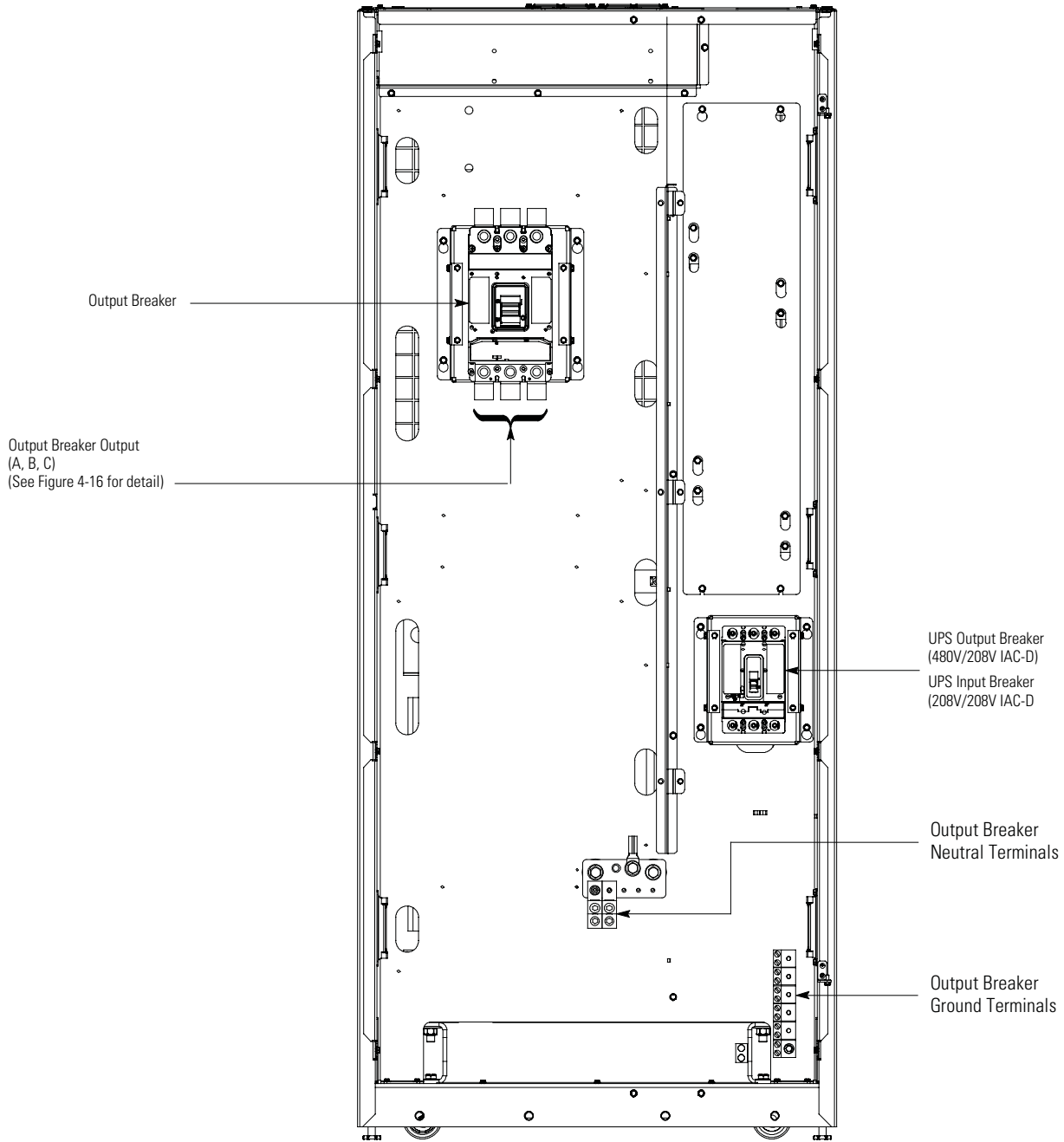

Figure 4-15. Output Breaker Output Power Terminal Locations – 50 kW and 100 kW

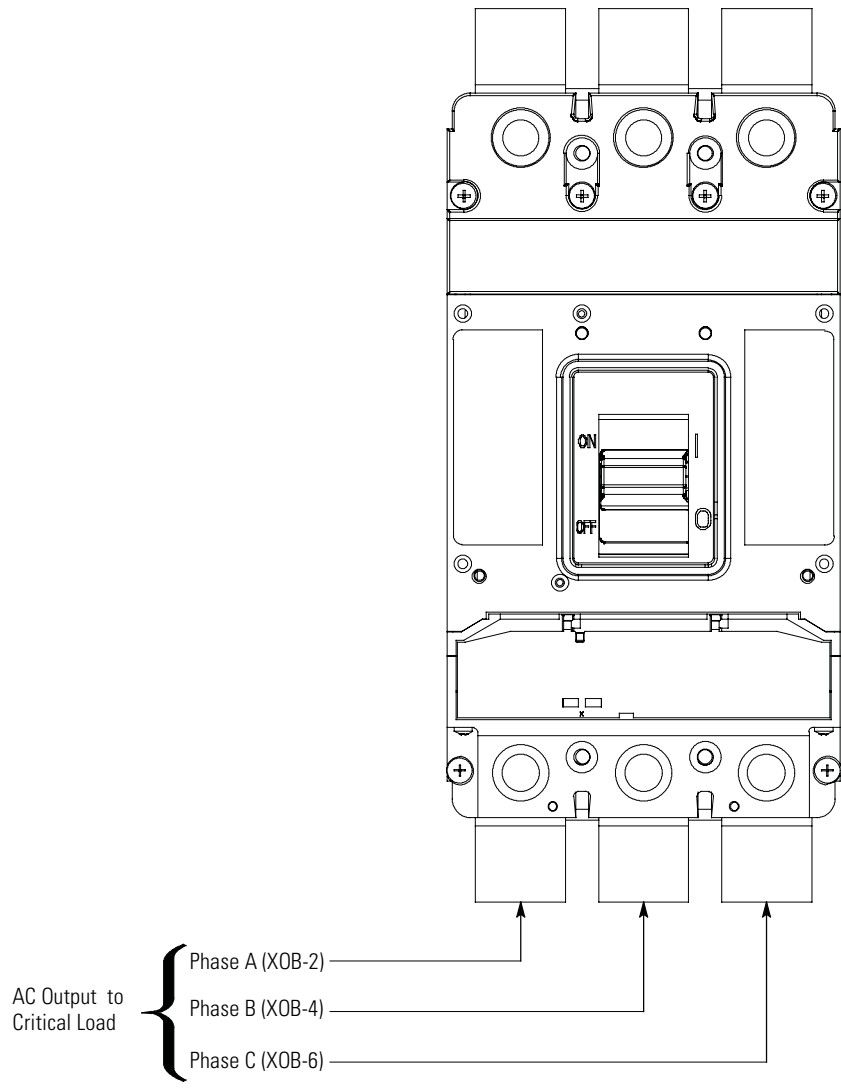



Figure 4-16. Output Breaker Output Power Terminal Detail – 50 kW and 100 kW

4.3.4 Two-Hole Barrel Lug Terminations to Bus Bar Installation

Paragraph 4.3.5 requires connecting the output breaker power wiring using 2-hole barrel lugs (see Table 3-12 for recommended lugs). See Figure 4-17 for the hardware sequence when installing the lugs to the bus bars. Tighten the bolt to the torque value listed in Table 3-10.

Proceed to paragraph 4.3.5.

NOTE  Conical washers are special purpose washers that look similar to flat washers, except for a slight conical shape. When installing conical washers, the top of the dome should be next to the bolt head and the base of the washer should be against a flat surface such as a bus bar, flat washer, or large terminal.

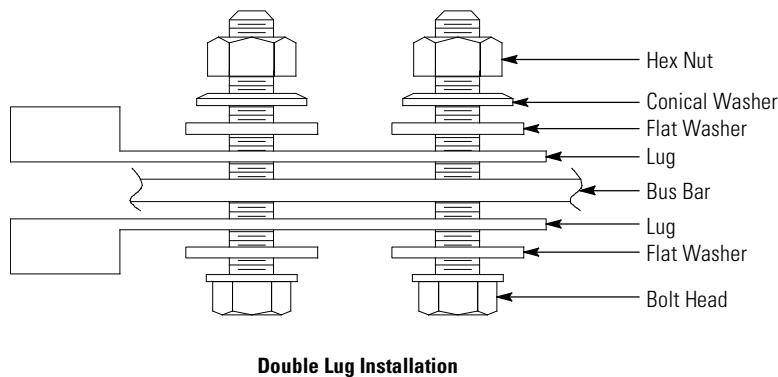



Figure 4-17. Typical Bus Bar Barrel Lug Mounting – Hardware Assembly Sequence

4.3.5 150 kW and 200 kW Output Wiring

To install wiring to connections:

1. If not already open, open the front door (see Figure 4-1) by lifting the latch from the bottom and turning to the right (counterclockwise) and swing the door open.
2. Loosen the screws securing the inside distribution panel door and swing the door open.
3. Loosen the screws securing the inside trim plate(s) and remove the plate(s). Retain trim plate(s) and hardware for later use.
4. If wiring an IAC-D with distribution panels, continue to Step 5; if wiring an IAC-D with subfeed breakers or an output breaker, skip to Step 7.
5. Install customer-supplied branch circuit breakers into the distribution panel (see Figure 4-11 or Figure 4-18). Use Cutler-Hammer bolt-on type BAB or QBHW breakers.

NOTE  When wiring branch circuits, begin adding conduits at the back of the bottom or top conduit landing plates to simplify future circuit additions.

6. Route output cables to the branch circuit breakers and wire the branch circuits according to the branch circuit breaker manufacturer's ratings and instructions, and national and local electrical codes (input is prewired to the panelboard). See Figure 4-11 or Figure 4-18, for neutral and ground terminal locations. See paragraph 3.2.2, Table 3-6 and Table 3-10 for IAC-D wiring and termination requirements.

7. If wiring an IAC-D with subfeed breakers or single subfeed breaker, continue to Step 8; if wiring an IAC-D with an output breaker, continue to Step 11, otherwise, skip to Step 14.



NOTE When wiring subfeed branch circuits, begin adding conduits at the back of the bottom or top conduit landing plates to simplify future circuit additions.

8. Route output cables from subfeed breaker terminal blocks to the critical load. See Figure 4-11, Figure 4-13, or Figure 4-18 for IAC-D output, neutral, and ground terminal locations. See paragraph 3.2.2, Table 3-6, and Table 3-10 for IAC-D wiring and termination requirements.
9. Connect phase A, B, and C, Neutral, and Ground power wiring to the subfeed breaker terminal blocks and the critical load.

For a detailed view of the IAC-D output terminals, see Figure 4-12, Figure 4-14, or Figure 4-19.
10. If adjustable subfeed breakers are installed, proceed to paragraph 4.4 to adjust current trip settings; otherwise, proceed to Step 14.
11. Locate the external wiring terminal hardware kit (see Table 3-11) packed at the bottom of the IAC-D.
12. Route output cables from output breaker to the critical load. See Figure 4-20 for IAC-D output, neutral, and ground terminal locations. See paragraph 3.2.2, Table 3-6, and Table 3-10 for IAC-D wiring and termination requirements.
13. Using hardware from the external wiring terminal hardware kit, connect phase A, B, and C, Neutral, and Ground power wiring to the output breaker and the critical load.

For a detailed view of the IAC-D terminals, see Figure 4-21.
14. Reinstall the inside trim plate removed in Step 3.
15. Close the inside door and secure with screws.
16. Close the outside door and secure the latch.
17. After the IAC-D is installed and wired, return to the applicable Eaton 93PM UPS installation and operation manual listed in paragraph 1.7 to complete the UPS wiring.

Installation

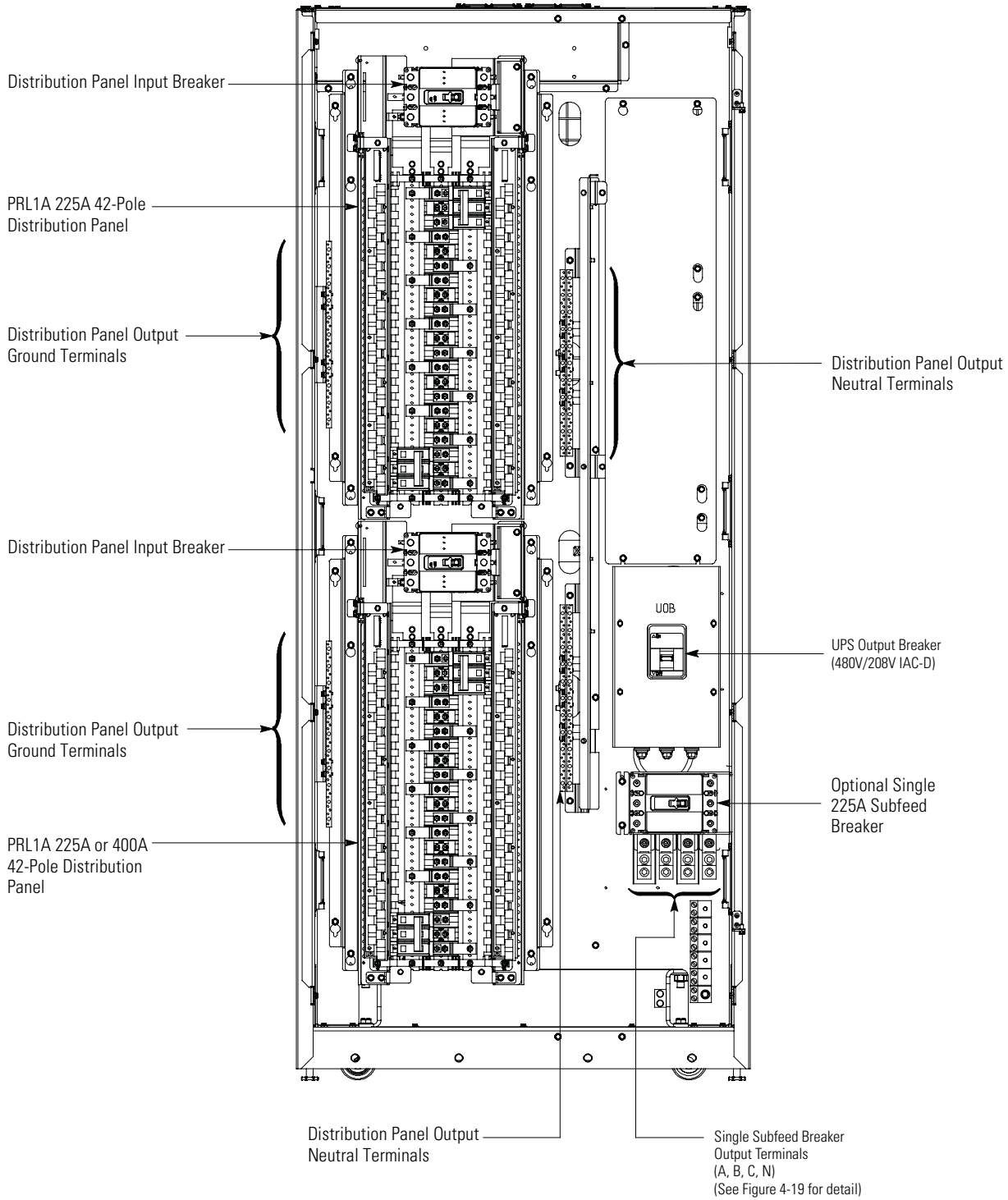

NOTE The IAC-D is shown with both top and bottom panelboards. However, the installed configuration may contain only a top or bottom panelboard or a combination of one panelboard and up to three subfeed breakers.

Figure 4-18. Distribution Panel Output Power Terminal Locations – 150 kW and 200 kW

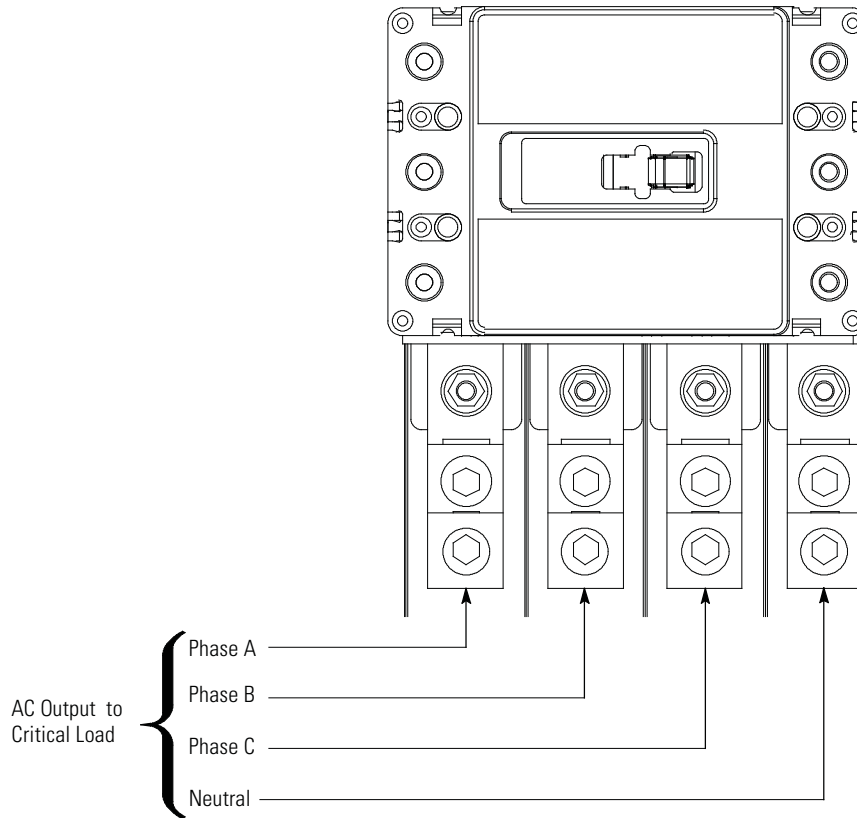

Figure 4-19. Single Subfeed Breaker Output Power Terminal Detail – 150 kW and 200 kW

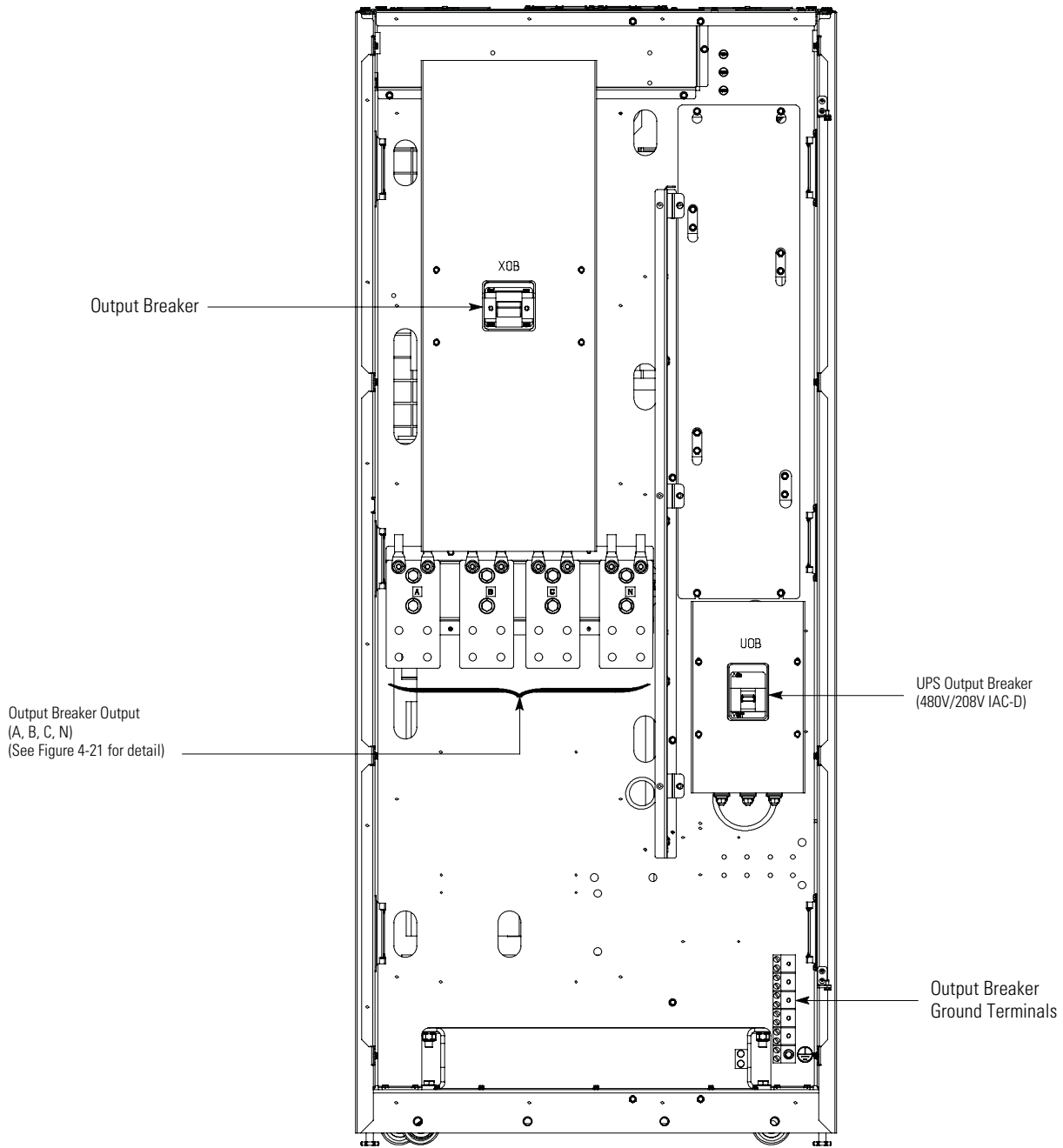

Figure 4-20. Output Breaker Output Power Terminal Locations – 150 kW and 200 kW

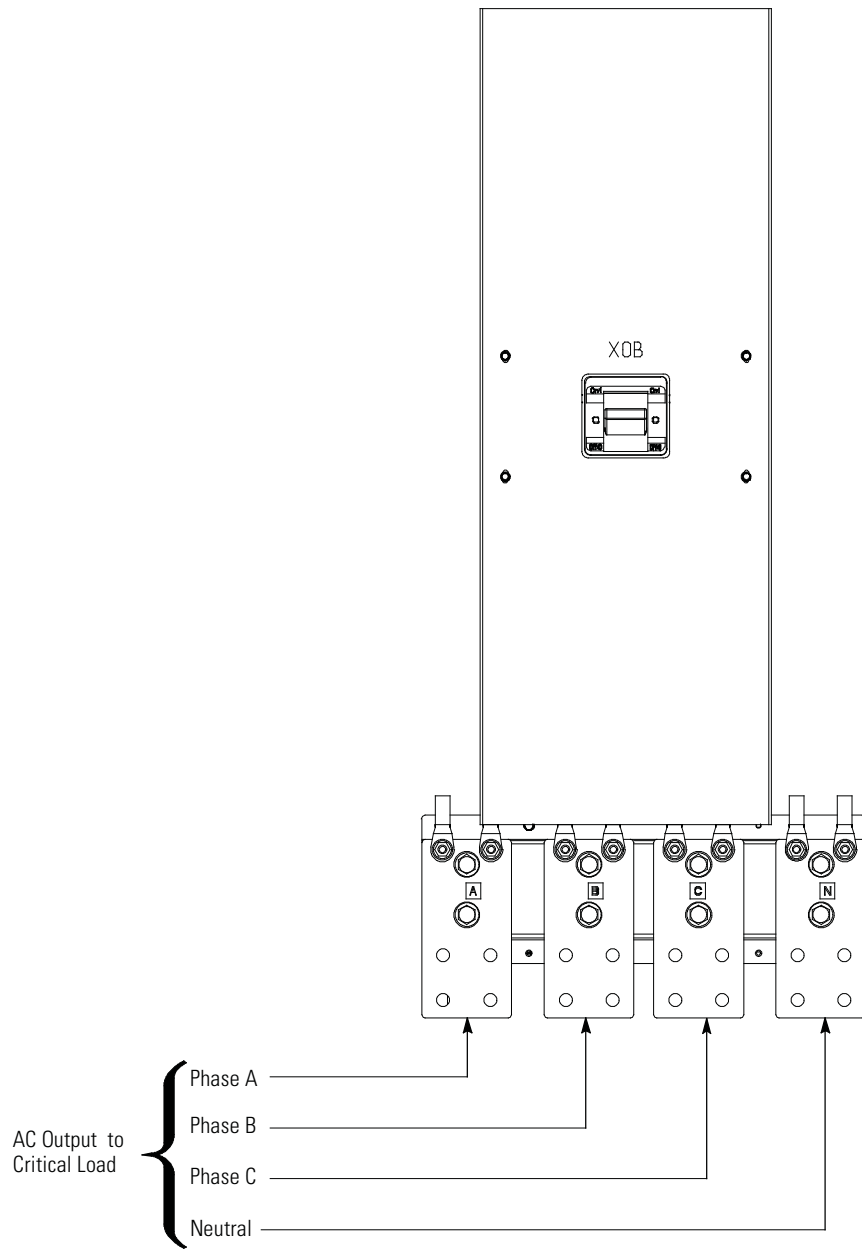

Figure 4-21. Output Breaker Output Power Terminal Detail – 150 kW and 200 kW

4.4 Adjustable Subfeed Breakers

The JG-Frame subfeed breakers installed in the IAC-D contain adjustable current trip settings. The continuous current (Ir) values for the corresponding lettered adjustment setting marked on the subfeed breakers are listed in Table 4-1.

To adjust breaker:

1. If not already open, open the front door (see Figure 4-1) by lifting the latch from the bottom and turning to the right (counterclockwise) and swing the door open.
2. Loosen the screws securing the inside distribution panel door and swing the door open.
3. Loosen the screws securing the inside trim plate(s) and remove the plate(s). Retain trim plate(s) and hardware for later use.
4. Using the dial on the subfeed breaker adjust the breaker current rating as required to protect the wiring to the load. See Table 4-1 for the breaker continuous current adjustment letter.
5. Reinstall the inside trim plate removed in Step 3.
6. Close the inside door and secure with screws.
7. Close the outside door and secure the latch.
8. After the IAC-D is installed and wired, return to the applicable Eaton 93PM UPS installation and operation manual listed in paragraph 1.7 to complete the UPS wiring.

Table 4-1. Subfeed Breaker Continuous Current (Ir) Settings

Breaker Setting	Continuous Current (Ir)
A	100A
B	125A
C	150A
D	160A
E	175A
F	200A
G	225A
H	250A

4.5 Neutral CT Interface Wiring

NOTE 1 Neutral CT interface wiring can be installed using the inter-cabinet wiring access pass through (line-up-and-match configurations) or conduit between cabinets (standalone configurations).

 **NOTE 2** If using conduit, install the control wiring in separate conduit from the power wiring.

NOTE 3 Remove the IAC-D conduit landing plates to drill or punch conduit holes, or remove knockouts in the conduit plate (see Figure 4-3).

4.5.1 Line-Up-and-Match Configuration

To install wiring:

1. Verify the UPS system is turned off and all power sources are removed. Refer to the applicable Eaton 93PM UPS Installation and Operation manual listed in paragraph 1.7, for UPS operating procedures.
2. If not already open, open the IAC-D front door (see Figure 4-1) by lifting the latch from the bottom and turning to the right (counterclockwise) and swing the door open.
3. Loosen the screws securing the inside distribution panel door and swing the door open.
4. If not already opened, open the UPS front door by lifting the latch from the bottom and turning to the right (counterclockwise) and swing the door open.
5. If not already removed, remove the screws securing the bottom internal safety shield panel and remove the panel to gain access to the interface terminals. Retain the hardware for later use.
6. If wiring the IAC-D Neutral CT interface terminals using the inter-cabinet wiring access pass-through (line-up-and-match configurations), proceed to Step 7; if wiring the IAC-T input power terminals using the bottom entry access, proceed to Step 10; if wiring the IAC-T input power terminals using the top entry sidecar, proceed to Step 13.
7. **Pass-through Wiring.** Locate the Neutral CT wiring harness in the bottom of the IAC-D.
8. Route the Neutral CT interface wiring between the IAC-D interface terminal block TB-CT and the UPS cabinet Neutral CT interface terminals using the inter-cabinet wiring access pass-through. Secure harness to wire tie anchors on right inside of IAC-D. See Figure 4-2 for wiring access information, and Figure 4-22 for IAC-D Neutral CT interface terminal location. See Figure 4-24, Figure 4-25, or Figure 4-26 for UPS Neutral CT interface terminal location. and refer to the applicable Eaton 93PM UPS Installation and Operation manual, listed in paragraph 1.7, for the UPS wiring access information.
9. Proceed to Step 15.
10. **Bottom Entry Wiring.** Using blue/white twisted pair (1 turn per 1 inch) 22AWG (Multi-strand), 600V, 105C wire, route the Neutral CT interface wiring between the IAC-D interface terminal block TB-CT and the UPS cabinet Neutral CT interface terminals using the bottom entry conduit landing plates on the IAC-D and the UPS. Secure wiring to wire tie anchors on right inside of IAC-D. See Figure 4-3 for wiring access information, and Figure 4-22 for IAC-D Neutral CT interface terminal location. See Figure 4-24, Figure 4-25, or Figure 4-26 for UPS Neutral CT interface terminal location. and refer to the applicable Eaton 93PM UPS Installation and Operation manual, listed in paragraph 1.7, for the UPS wiring access information.
11. Install fully insulated 22-18 AWG Faston connectors (AMP 2-520183-2 or equivalent) on the UPS end of the Neutral CT interface wiring.
12. Proceed to Step 15.

13. **Top Entry Wiring.** Using blue/white twisted pair (1 turn per 1 inch) 22AWG (Multi-strand), 600V, 105C wire, route the Neutral CT interface wiring between the IAC-D interface terminal block TB-CT and the UPS cabinet Neutral CT interface terminals using the top entry conduit landing plates on the IAC-D and the UPS. Secure wiring to wire tie anchors on right inside of IAC-D. See Figure 4-3 for wiring access information, and Figure 4-22 for IAC-D Neutral CT interface terminal location. See Figure 4-24, Figure 4-25, or Figure 4-26 for UPS Neutral CT interface terminal location. and refer to the applicable Eaton 93PM UPS Installation and Operation manual, listed in paragraph 1.7, for the UPS wiring access information. paragraph 1.7, for the UPS wiring access information, terminal locations, and termination requirements.
14. Install fully insulated 22-18 AWG Faston connectors (AMP 2-520183-2 or equivalent) on the UPS end of the Neutral CT interface wiring.
15. If installed, remove the jumper from terminal block and connect the IAC-D Neutral CT interface wiring to the IAC-D Neutral CT terminals. See paragraph 3.2.2 and Table 4-2 for terminal block wiring, terminal assignments, and termination requirements.

For a detailed view of the IAC-T terminals, see Figure 4-23.
16. Connect the Neutral CT Faston connectors from the IAC-D to the UPS Neutral CT Faston connectors (blue wire J19+ to blue wire P19+ and white wire J19– to white wire P19–).
17. Close the IAC-D inside door and secure with screws.
18. Close the IAC-D outside door and secure the latch.
19. Reinstall the UPS internal safety shield panel removed in Step 5.
20. Close the UPS outside door and secure the latch.
21. After the IAC-D is installed and wired, return to the applicable Eaton 93PM UPS installation and operation manual listed in paragraph 1.7 to complete the UPS wiring.

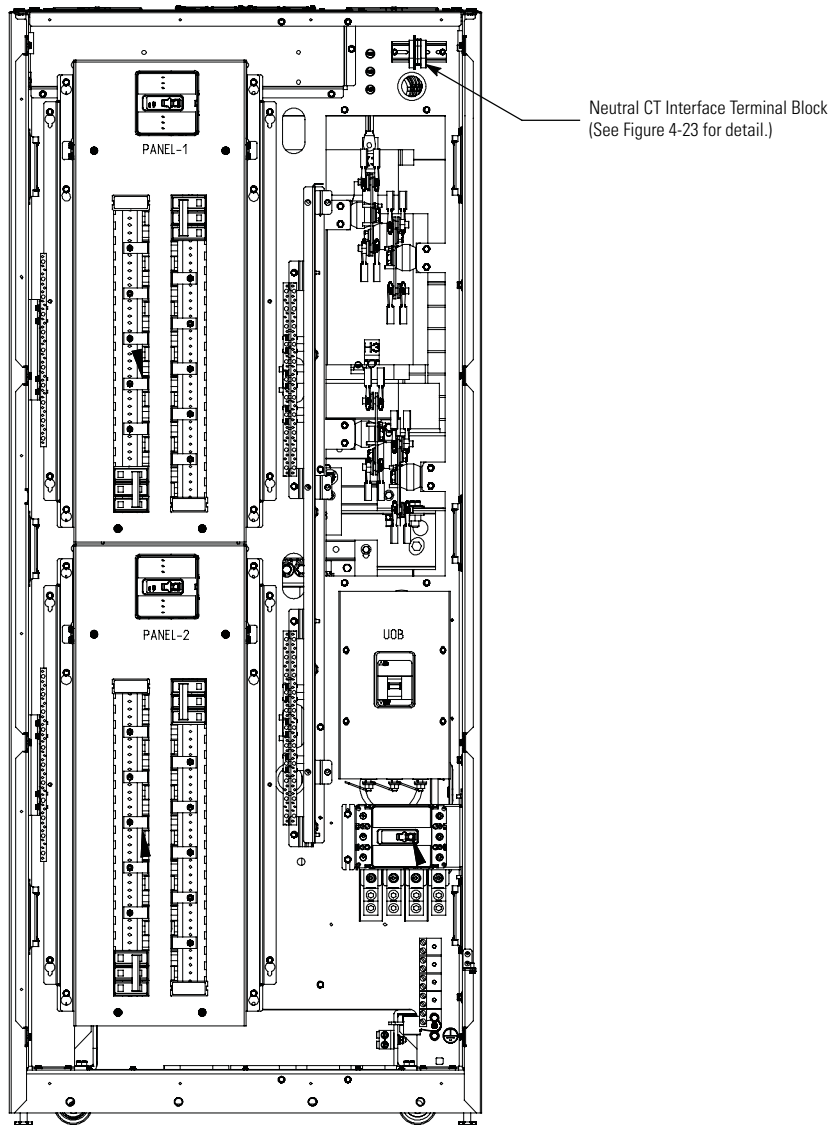

Figure 4-22. 93PM IAC-D Neutral CT Interface Terminal Location

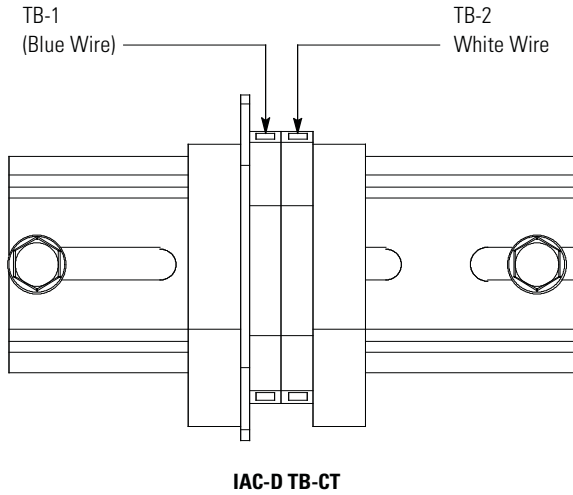

Figure 4-23. 93PM IAC-D Neutral CT Interface Terminal Detail

Table 4-2. IAC-D Neutral CT Interface Wiring Terminal Block Terminations

Terminal	Name	Description	Recommended Wire Size	Size of Pressure Termination	Tightening Torque	Comments
1	TB-1	Neutral CT Positive	Twisted Pair Wires #18 AWG (600V, 105°C)	#12–#26 AWG	0.4 (3.5) - 0.8 (7.1)	Strip wire insulation back 7 millimeters to wire terminal blocks.
2	TB-2	Neutral CT Negative				

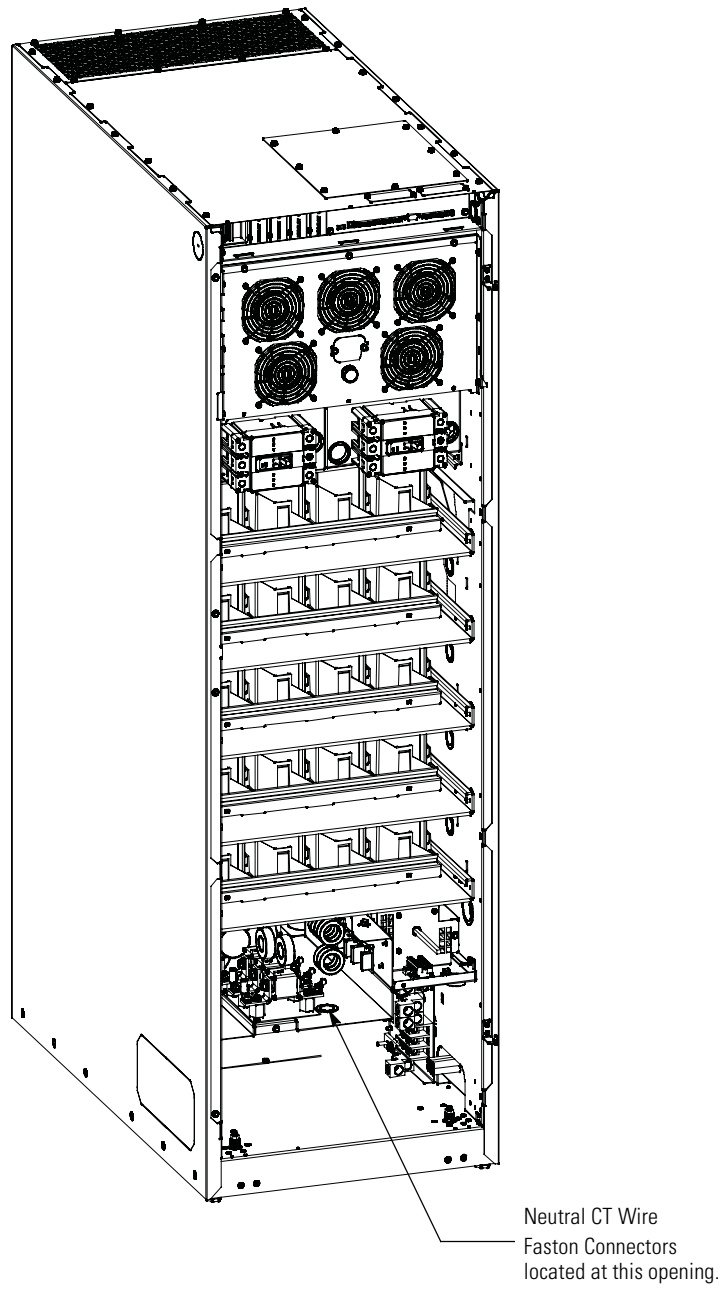
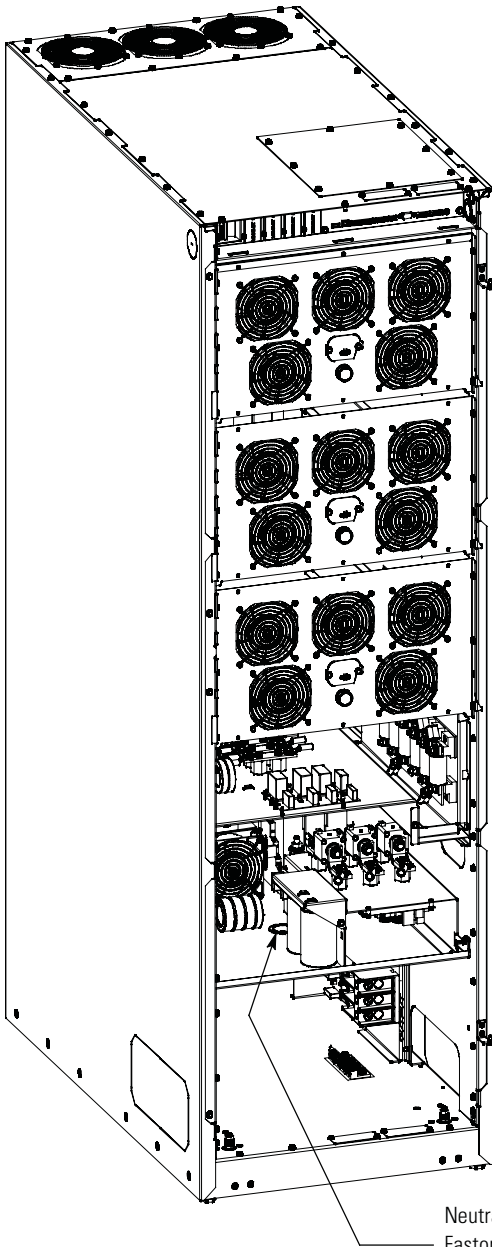

Figure 4-24. 50 kW UPS Neutral CT Interface Terminal Location



Neutral CT Wire
Faston Connectors
located at this opening.

Figure 4-25. 100 kW and 150 kW Capacity UPS Neutral CT Interface Terminal Location

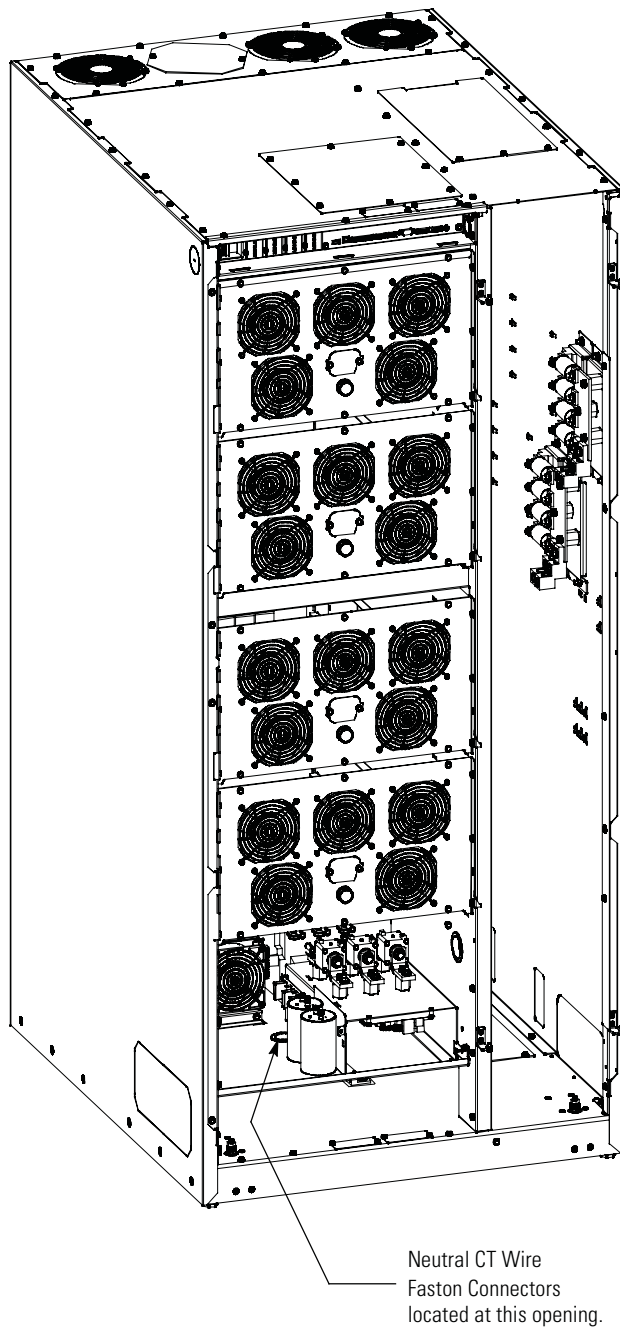

Figure 4-26. 150 kW Redundant and 200 kW UPS Neutral CT Interface Terminal Location

4.6 Initial Startup

Startup and operational checks must be performed by an authorized Eaton Customer Service Engineer, or the warranty terms specified on page W-1 become void. This service is offered as part of the sales contract for the UPS. Contact an Eaton service representative in advance (usually a two-week notice is required) to reserve a preferred startup date.

4.7 Completing the Installation Checklist

The final step in installing the IAC-D is completing the following Installation Checklist. This checklist ensures that you have completely installed all hardware, cables, and other equipment. Complete all items listed on the checklist to ensure a smooth installation. Make a copy of the Installation Checklist before filling it out, and retain the original.

After the installation is complete, an Eaton Customer Service Engineer must verify the operation of the UPS system and commission it to support the critical load. The service representative cannot perform any installation tasks other than verifying software and operating setup parameters. Service personnel may request a copy of the completed Installation Checklist to verify all applicable equipment installations have been completed.



NOTE

The Installation Checklist MUST be completed prior to starting the UPS system for the first time.

Installation Checklist

- All packing materials and restraints have been removed from each cabinet.
- The IAC-D is installed on a level floor suitable for computer or electronic equipment.
- The IAC-D is placed in its installed location
- The IAC-D is secured to the building floor or attached to the adjacent 93PM system cabinet with the cabinet bracket
- All conduits and cables are properly routed between the IAC-D and the UPS.
- All power cables are properly sized and terminated.
- Distribution Panel branch circuit breakers are installed and wired to load.
- A ground conductor is properly installed.
- All terminal cover plates are installed.
- Air conditioning equipment is installed and operating correctly.
- The area around the UPS system is clean and dust-free.
- Adequate workspace exists around the IAC-D and other cabinets.
- Adequate lighting is provided around all IAC-D and UPS equipment.
- A 120 Vac service outlet is located within 7.5 meters (25 feet) of the IAC-D and UPS equipment.
- Startup and operational checks are performed by an authorized Eaton Customer Service Engineer.

This page intentionally left blank.

Section 2

Operation

Chapter 5 Onelines and Schematics

5.1 Onelines

Figure 5-1 through Figure 5-8 show the simplified internal structure of the Integrated Accessory Cabinet-Distribution (IAC-D).

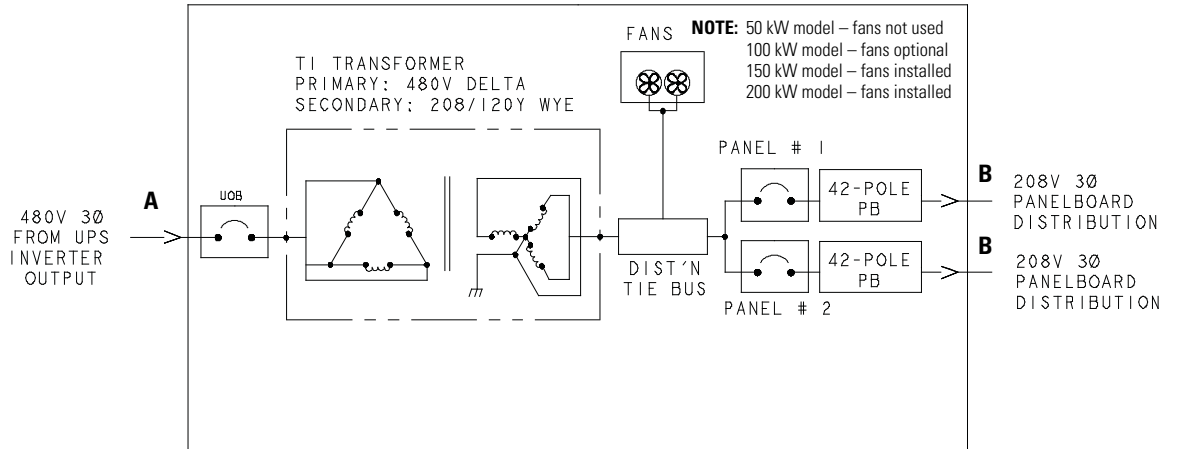

NOTE Callout letters **A** and **B** map to Table 3-4 and Table 3-6.

Figure 5-1. 93PM IAC-D (480V/208V) Internal Oneline – 50 kW, 100 kW, 150 kW, and 200 kW with Two PRL1A Panelboards

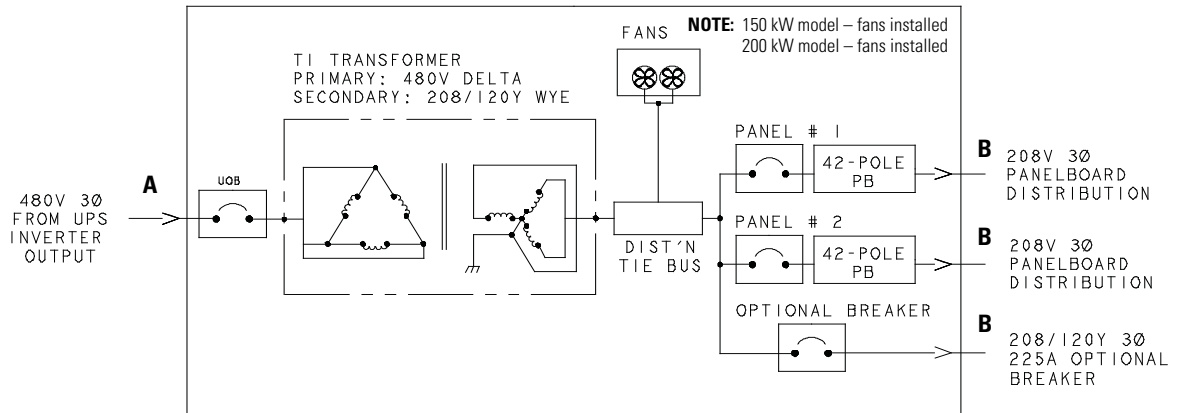

NOTE Callout letters **A** and **B** map to Table 3-4 and Table 3-6.

Figure 5-2. 93PM IAC-D (480V/208V) Internal Oneline – 150 kW and 200 kW with Two PRL1A Panelboards and Optional Single Subfeed Breaker

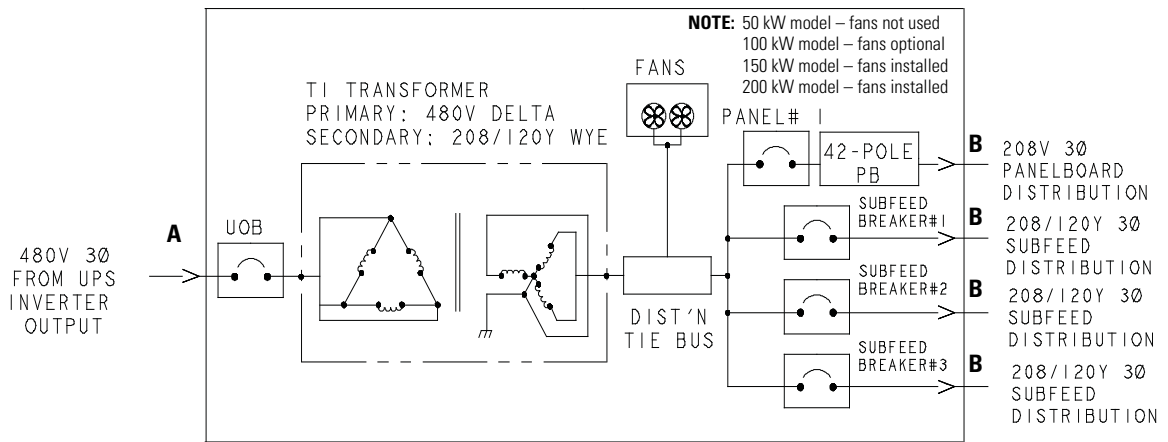

NOTE Callout letters **A** and **B** map to Table 3-4 and Table 3-6.

Figure 5-3. 93PM IAC-D (480V/208V) Internal Oneline – 50 kW, 100 kW, 150 kW, and 200 kW with Top PRL1A Panelboard and Three 100–250A Adjustable Subfeed Breakers

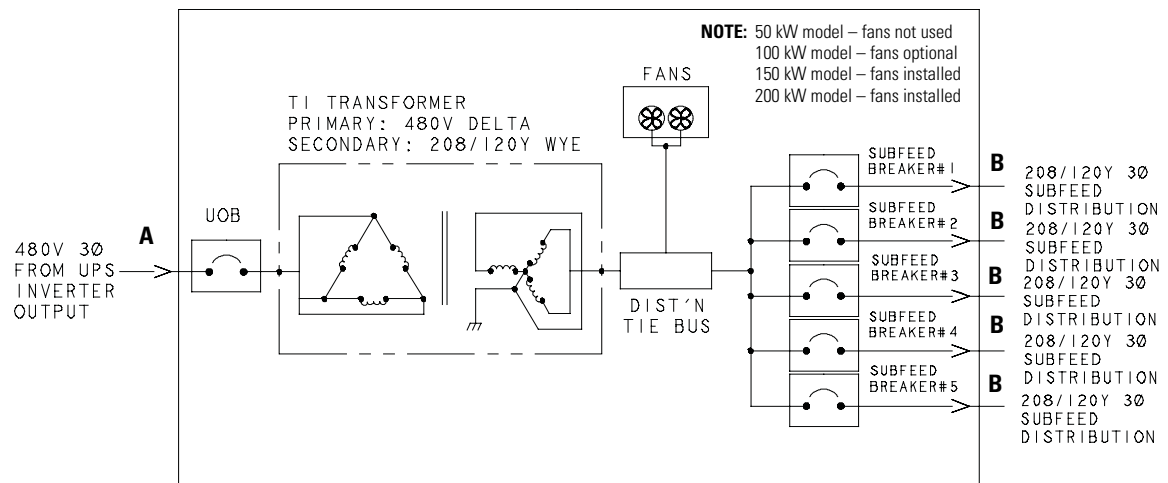

NOTE Callout letters **A** and **B** map to Table 3-4 and Table 3-6.

Figure 5-4. 93PM IAC-D (480V/208V) Internal Oneline – 50 kW, 100 kW, 150 kW, and 200 kW with Five 100–250A Adjustable Subfeed Breakers

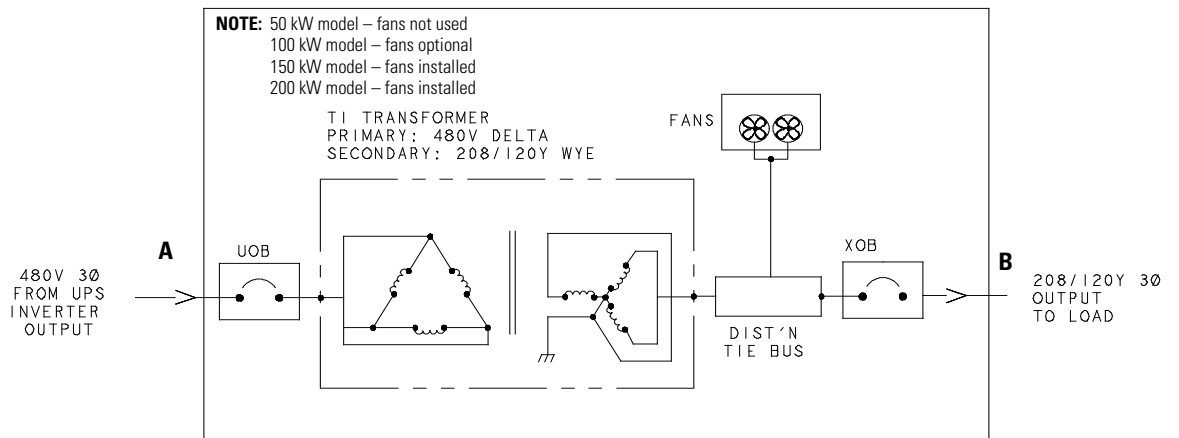

NOTE Callout letters **A** and **B** map to Table 3-4 and Table 3-6.

Figure 5-5. 93PM IAC-D (480V/208V) Internal Oneline – 175A, 350A, 600A, or 700A Output Breaker

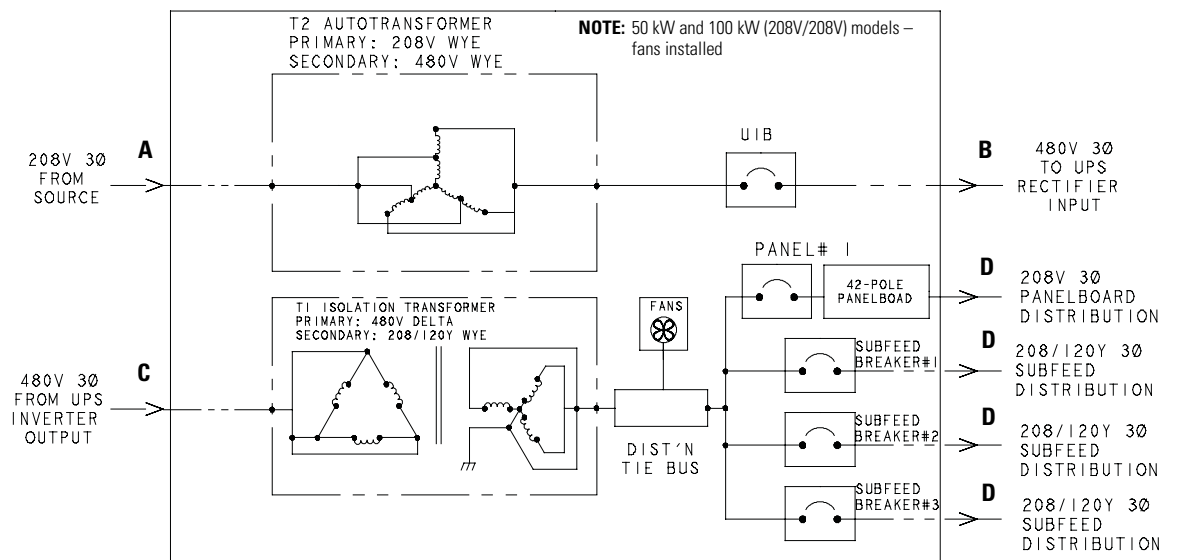

NOTE Callout letters **A** and **B** map to Table 3-5 and Table 3-7.

Figure 5-6. 93PM IAC-D (208V/208V) Internal Oneline – 50 kW and 100 kW with Top PRL1A Panelboard and Three 100–250A Adjustable Subfeed Breakers

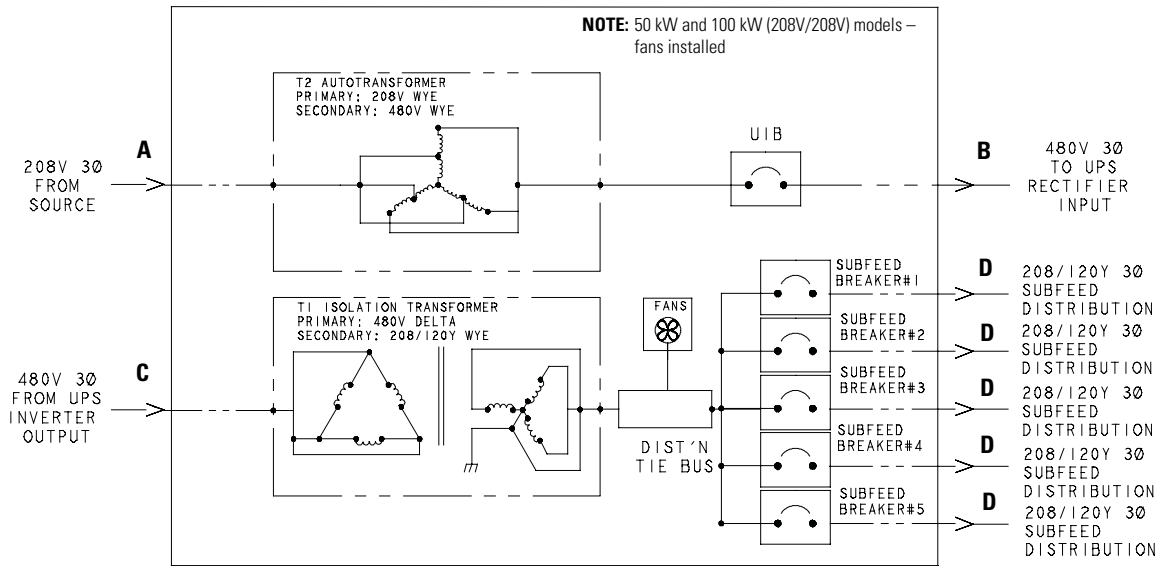

NOTE Callout letters **A** and **B** map to Table 3-5 and Table 3-7.

Figure 5-7. 93PM IAC-D (208V/208V) Internal Oneline – 50 kW and 100 kW with Five 100–250A Adjustable Subfeed Breakers

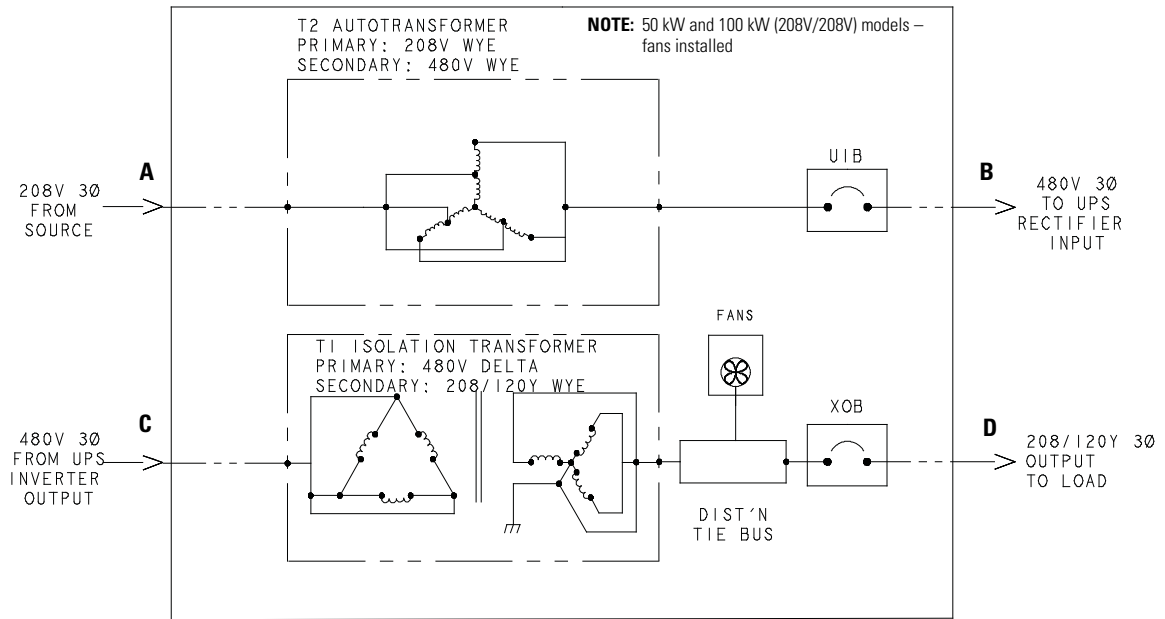

NOTE Callout letters **A** and **B** map to Table 3-5 and Table 3-7.

Figure 5-8. 93PM IAC-D (208V/208V) Internal Oneline – 50 kW with 175A Output Breaker or 100 kW with 350A Output Breaker

5.2 Schematics

Figure 5-9 through Figure 5-23 show the IAC-D schematics.

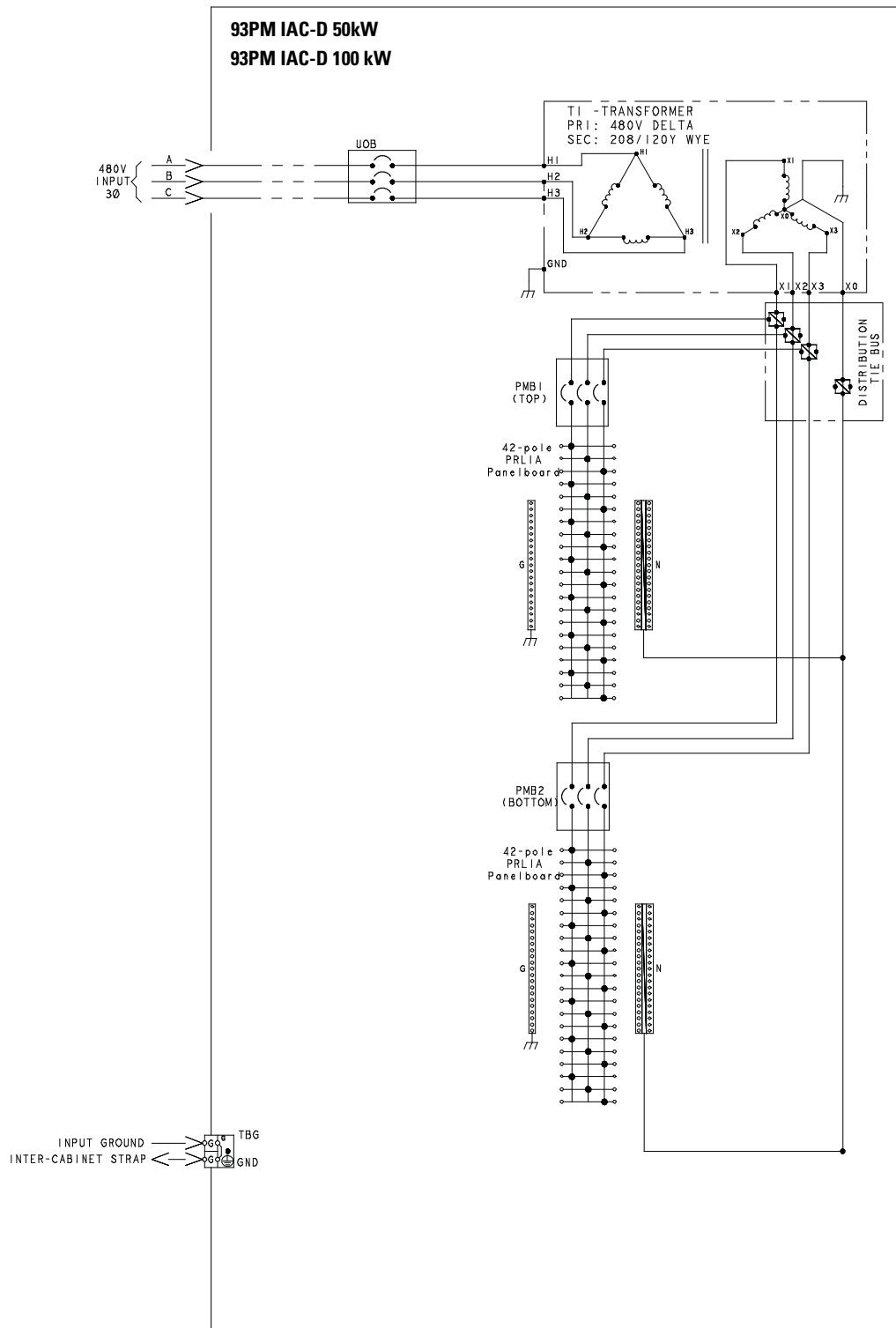

Figure 5-9. 93PM IAC-D (50 kW and 100 kW, 480V/208V) Schematic – Two PRL1A Panelboards without Fans

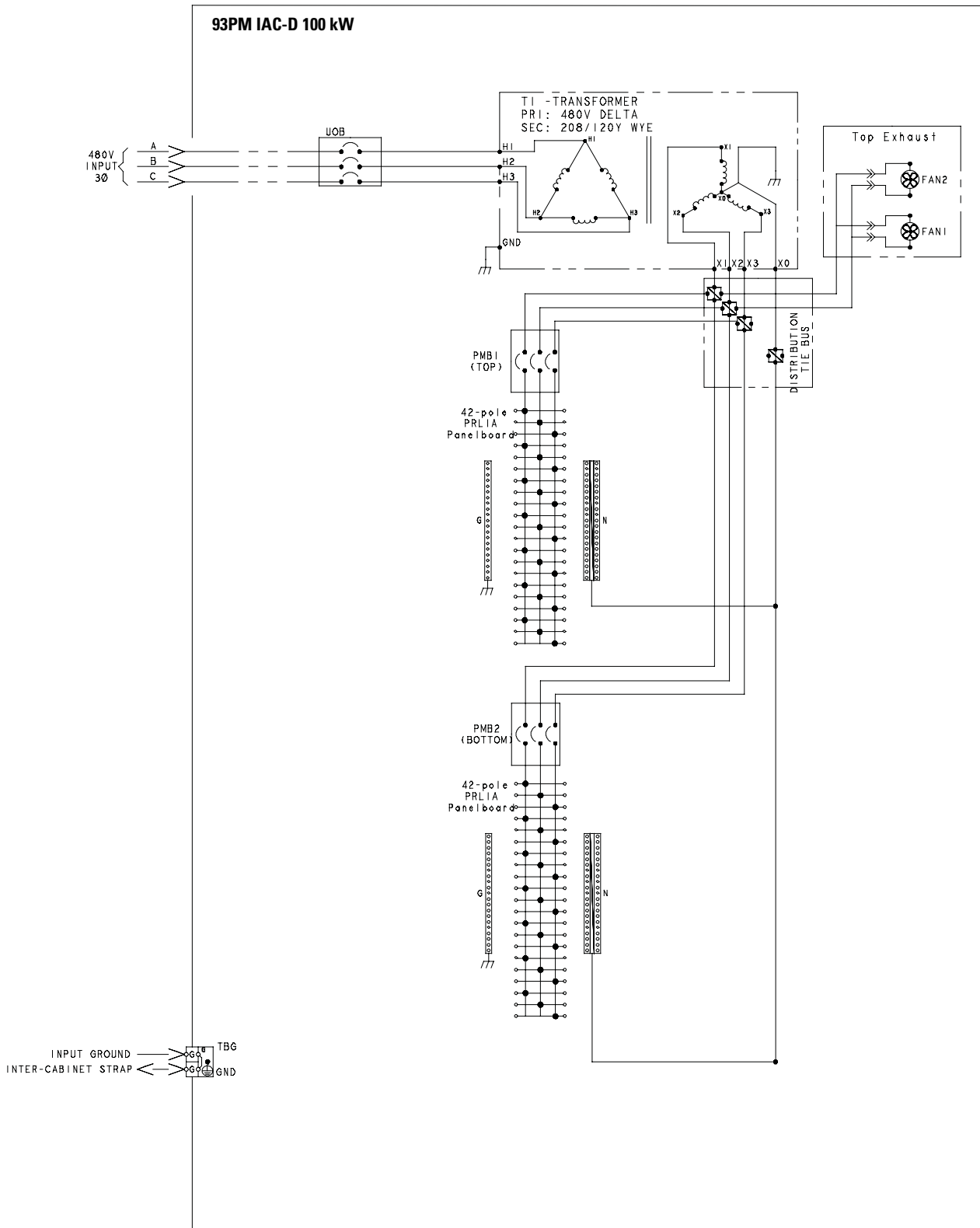

Figure 5-10. 93PM IAC-D (100 kW, 480V/208V) Schematic – Two PRL1A Panelboards with Fans

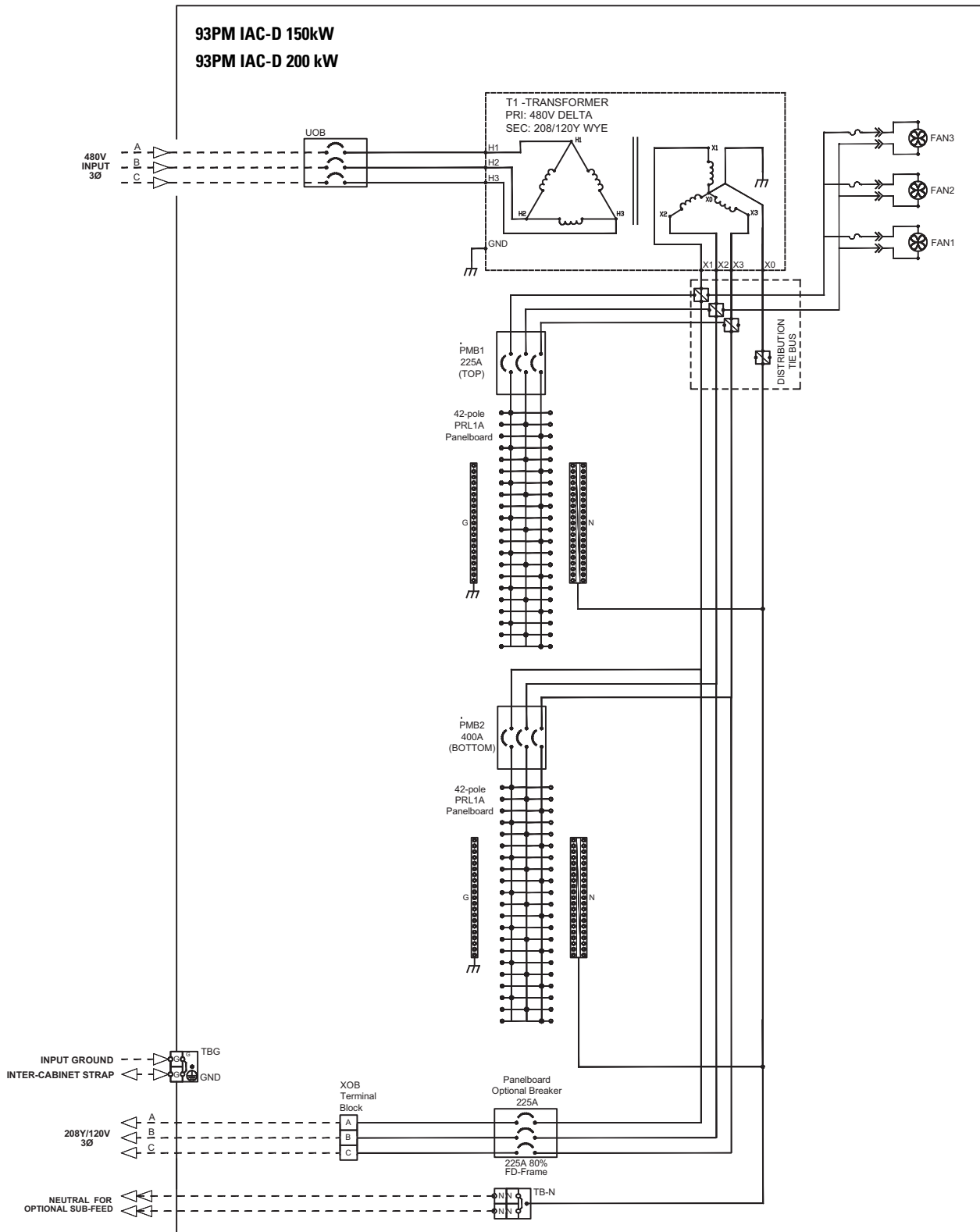

Figure 5-11. 93PM IAC-D (150 kW and 200 kW, 480V/208V) Schematic – Two PRL1A Panelboards

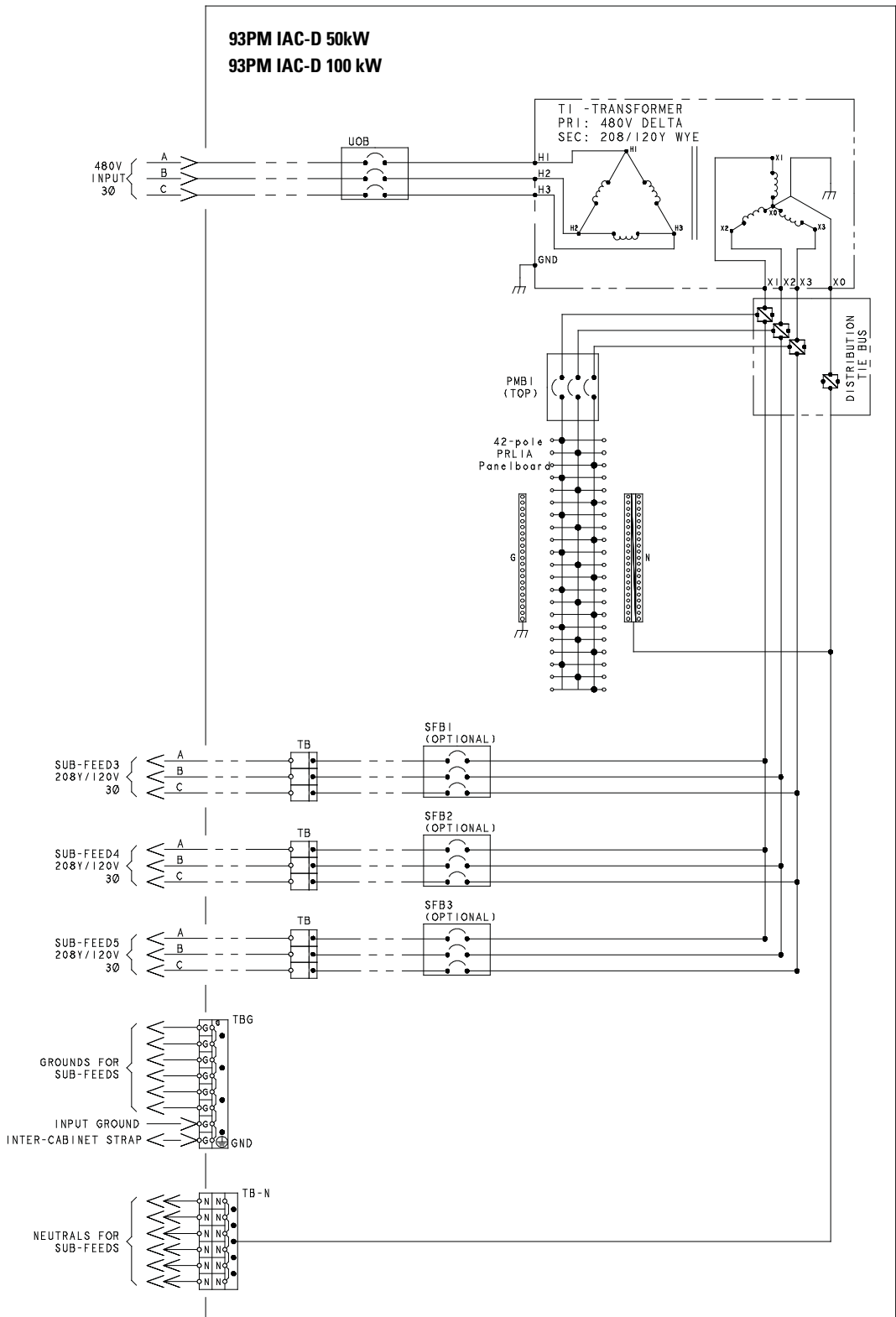

Figure 5-12. 93PM IAC-D (50 kW and 100 kW, 480V/208V) Schematic – Top PRL1A Panelboard and Three 100-250A Adjustable Subfeed Breakers without Fans

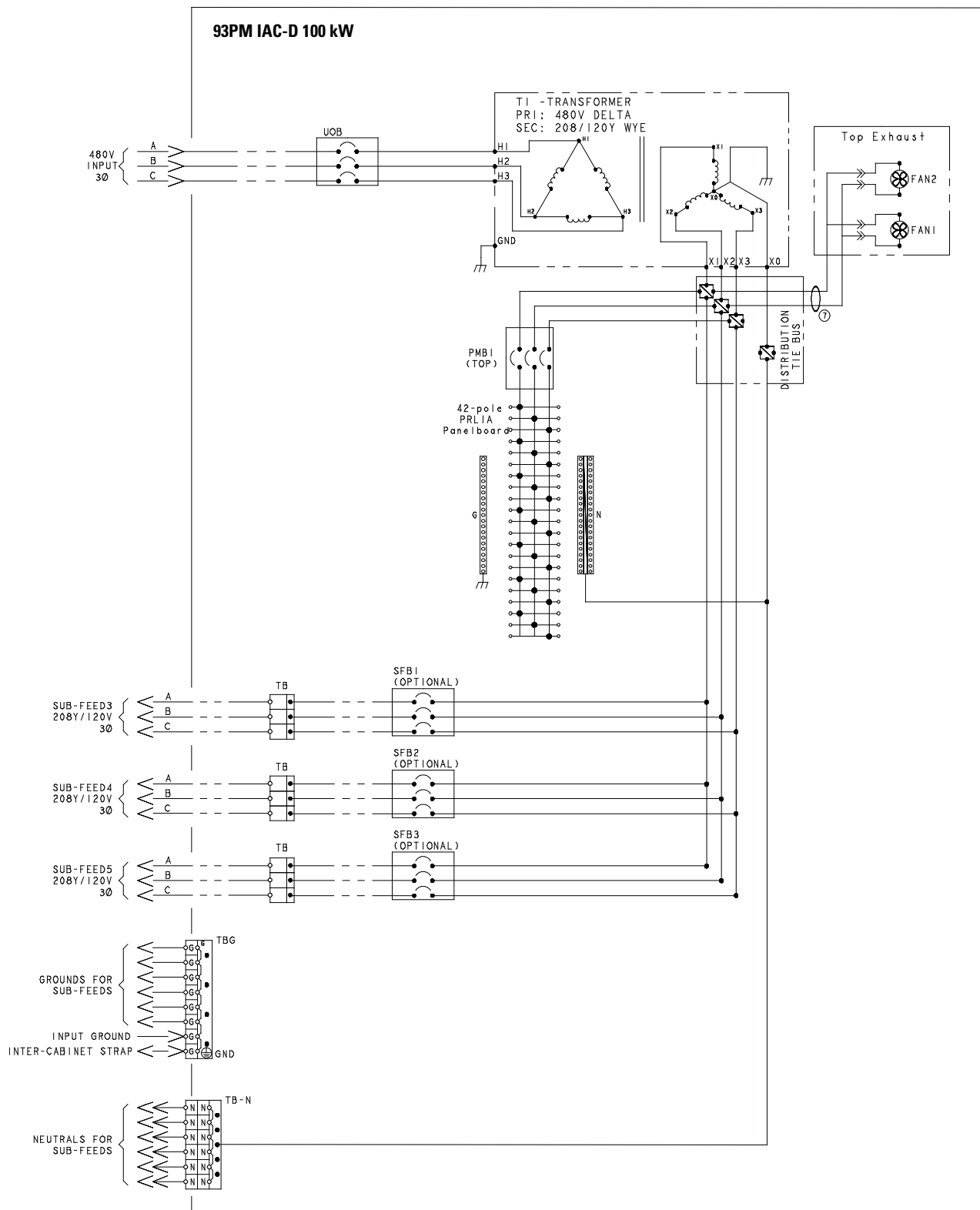

Figure 5-13. 93PM IAC-D (100 kW, 480V/208V) Schematic – Top PRL1A Panelboard and Three 100-250A Adjustable Subfeed Breakers with Fans

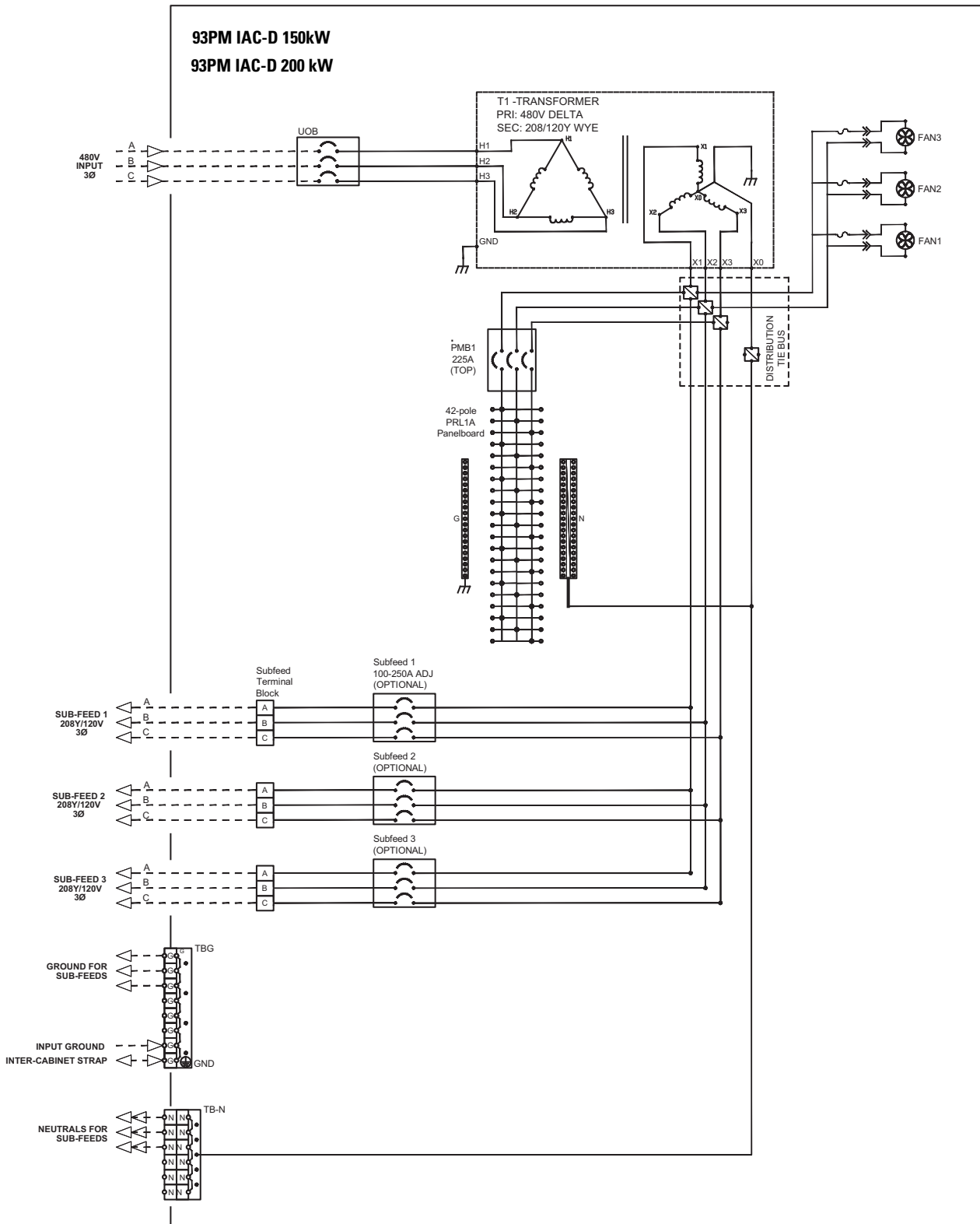

Figure 5-14. 93PM IAC-D (150 kW and 200 kW, 480V/208V) Schematic – Top PRL1A Panelboard and Three 100-250A Adjustable Subfeed Breakers

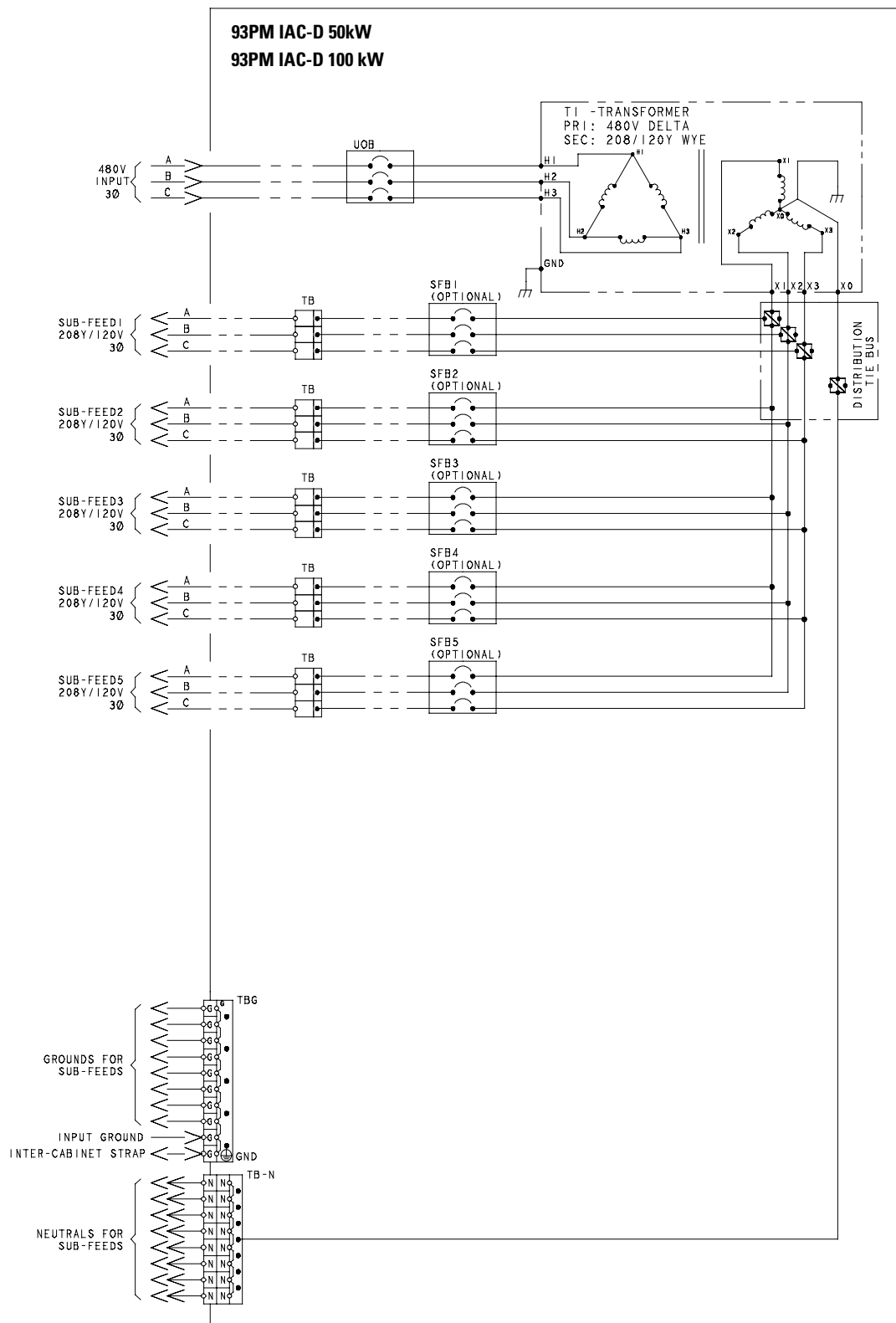

Figure 5-15. 93PM IAC-D (50 kW and 100 kW, 480V/208V) Schematic – Five 100-250A Adjustable Subfeed Breakers without Fans

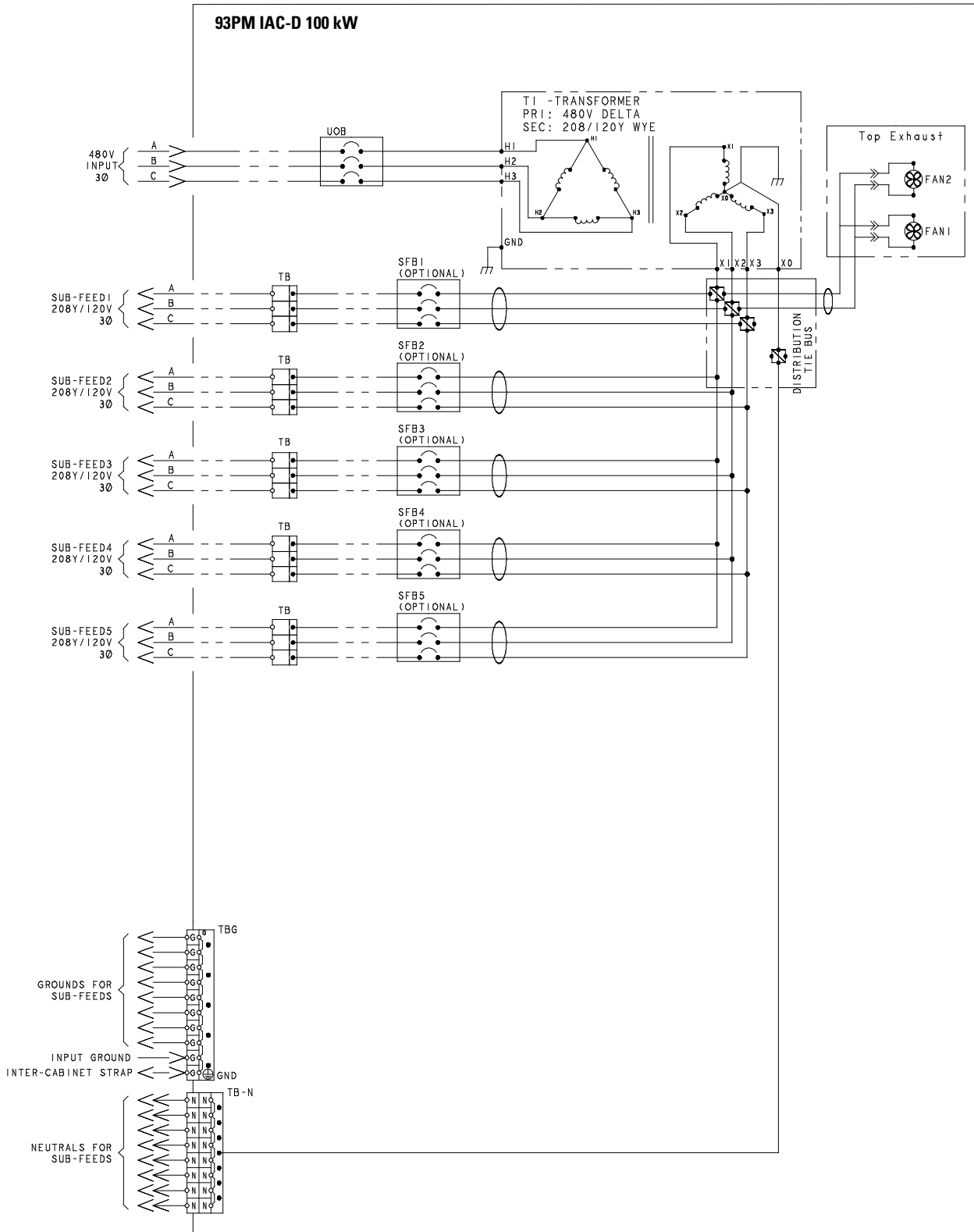

Figure 5-16. 93PM IAC-D (100 kW, 480V/208V) Schematic – Five 100-250A Adjustable Subfeed Breakers with Fans

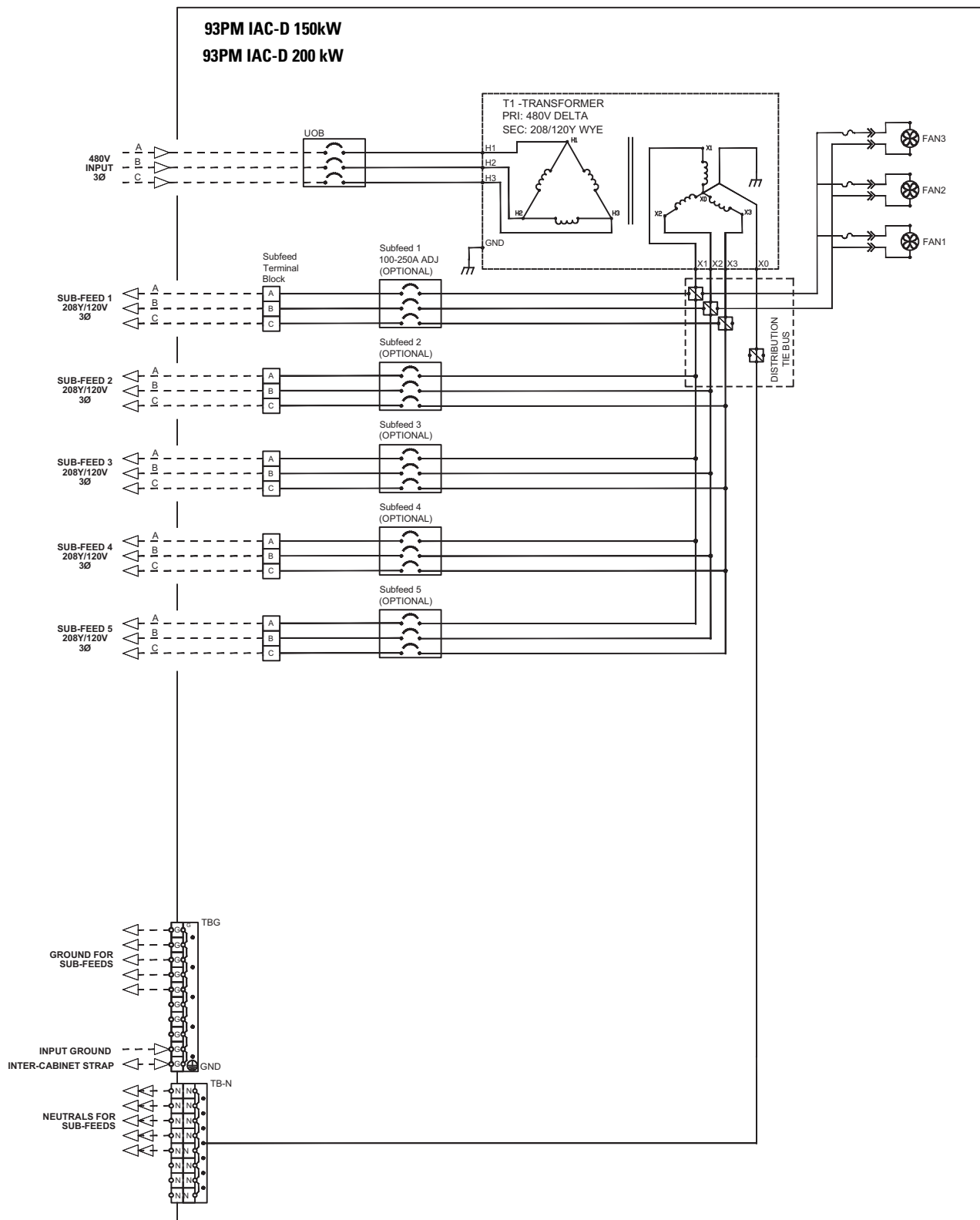

Figure 5-17. 93PM IAC-D (150 kW and 200 kW, 480V/208V) Schematic – Five 100-250A Adjustable Subfeed Breakers

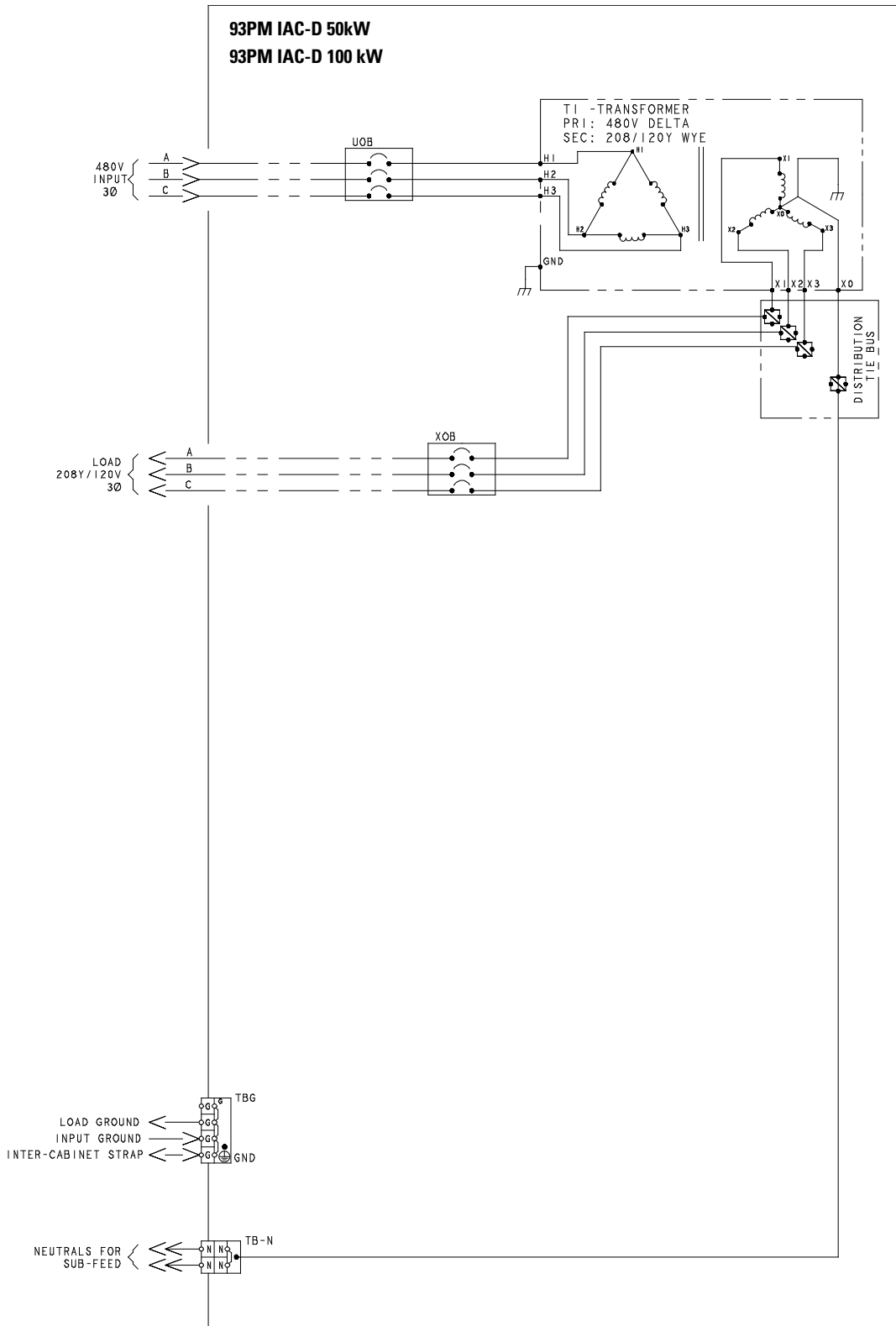

Figure 5-18. 93PM IAC-D (50 kW or 100 kW 480V/208V) Schematic – 175A or 350A Output Breaker without Fans

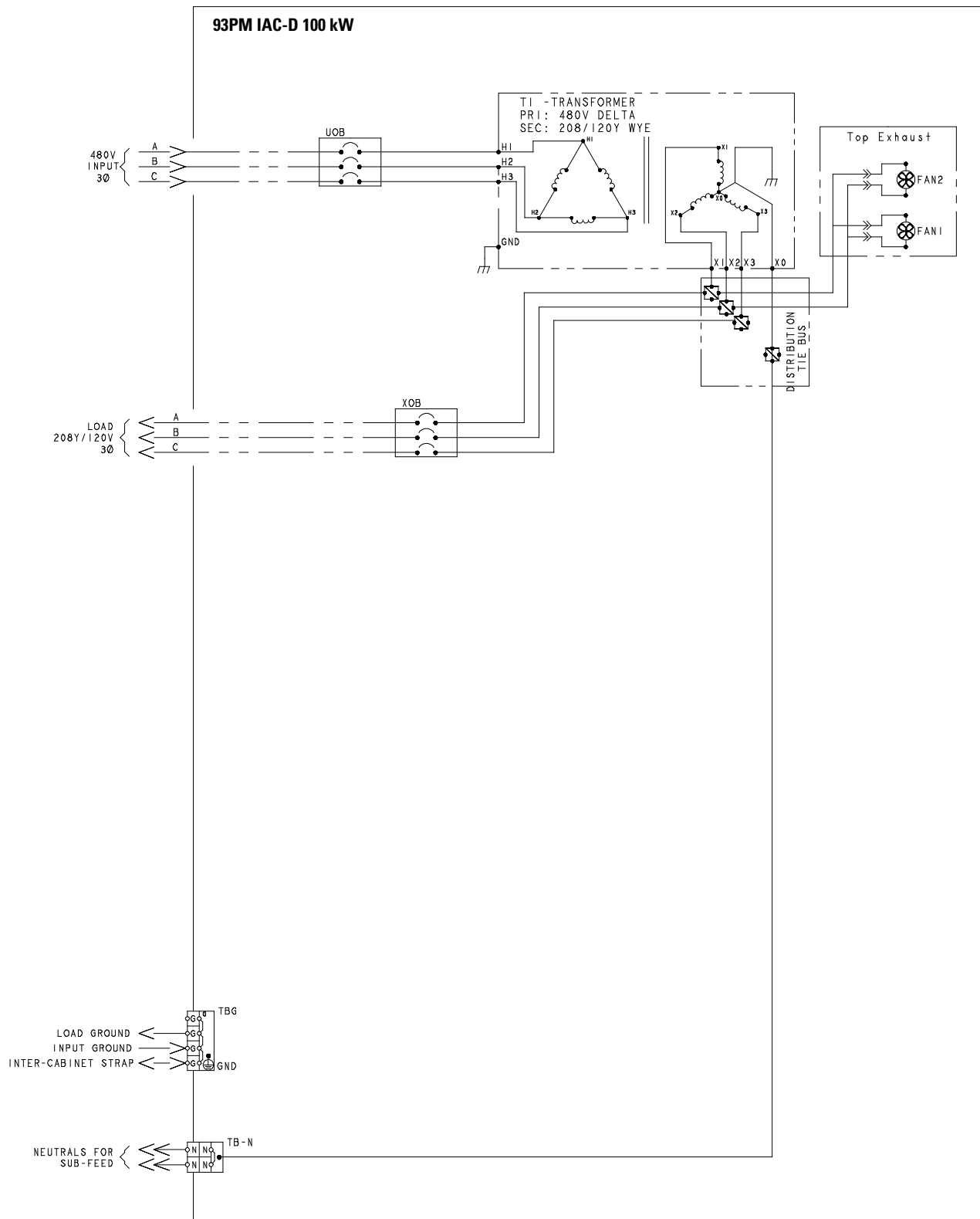

Figure 5-19. 93PM IAC-D (100 kW, 480V/208V) Schematic – 350A Output Breaker with Fans

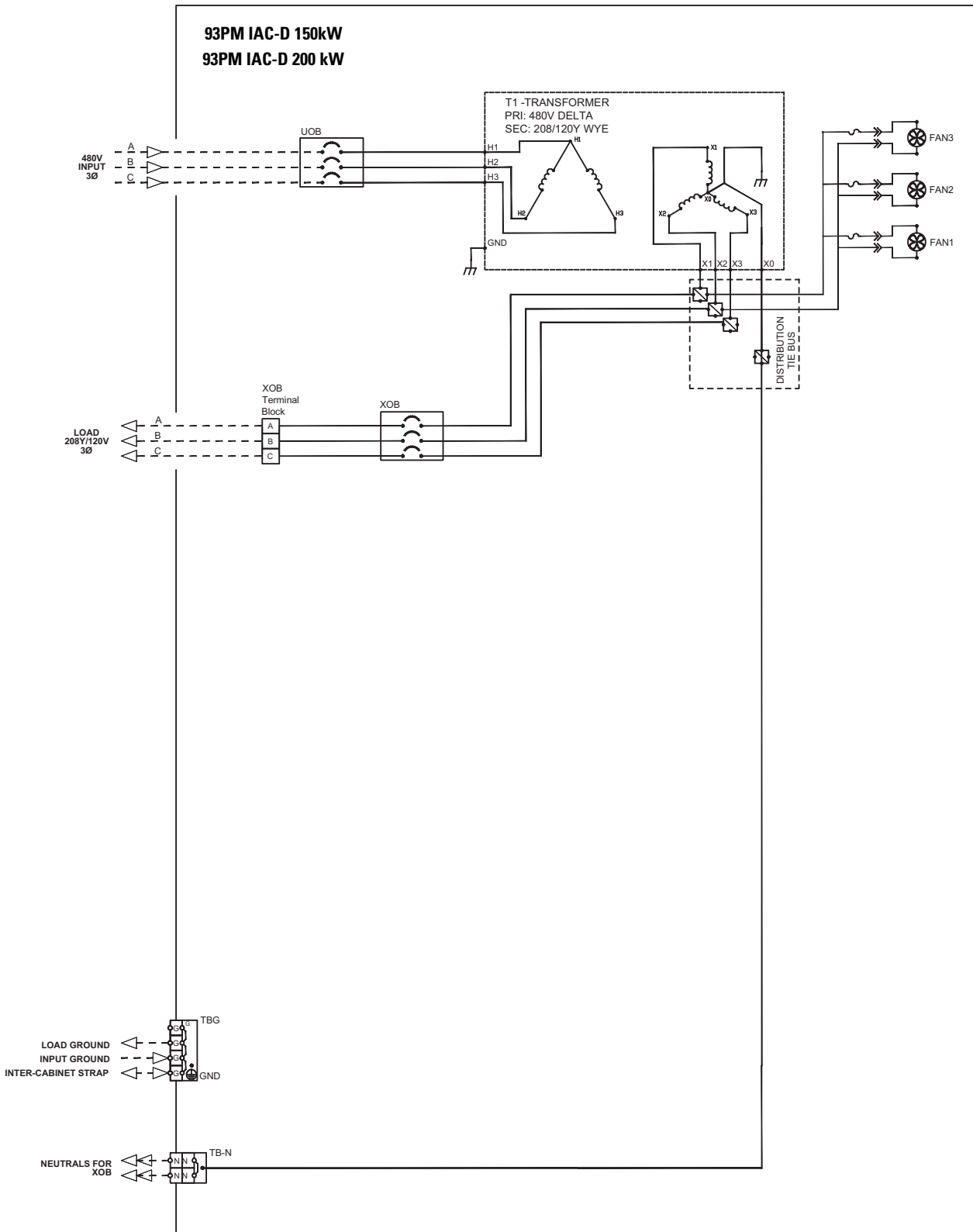

Figure 5-20. 93PM IAC-D (150 kW and 200 kW, 480V/208V) Schematic – 600A or 700A Output Breaker

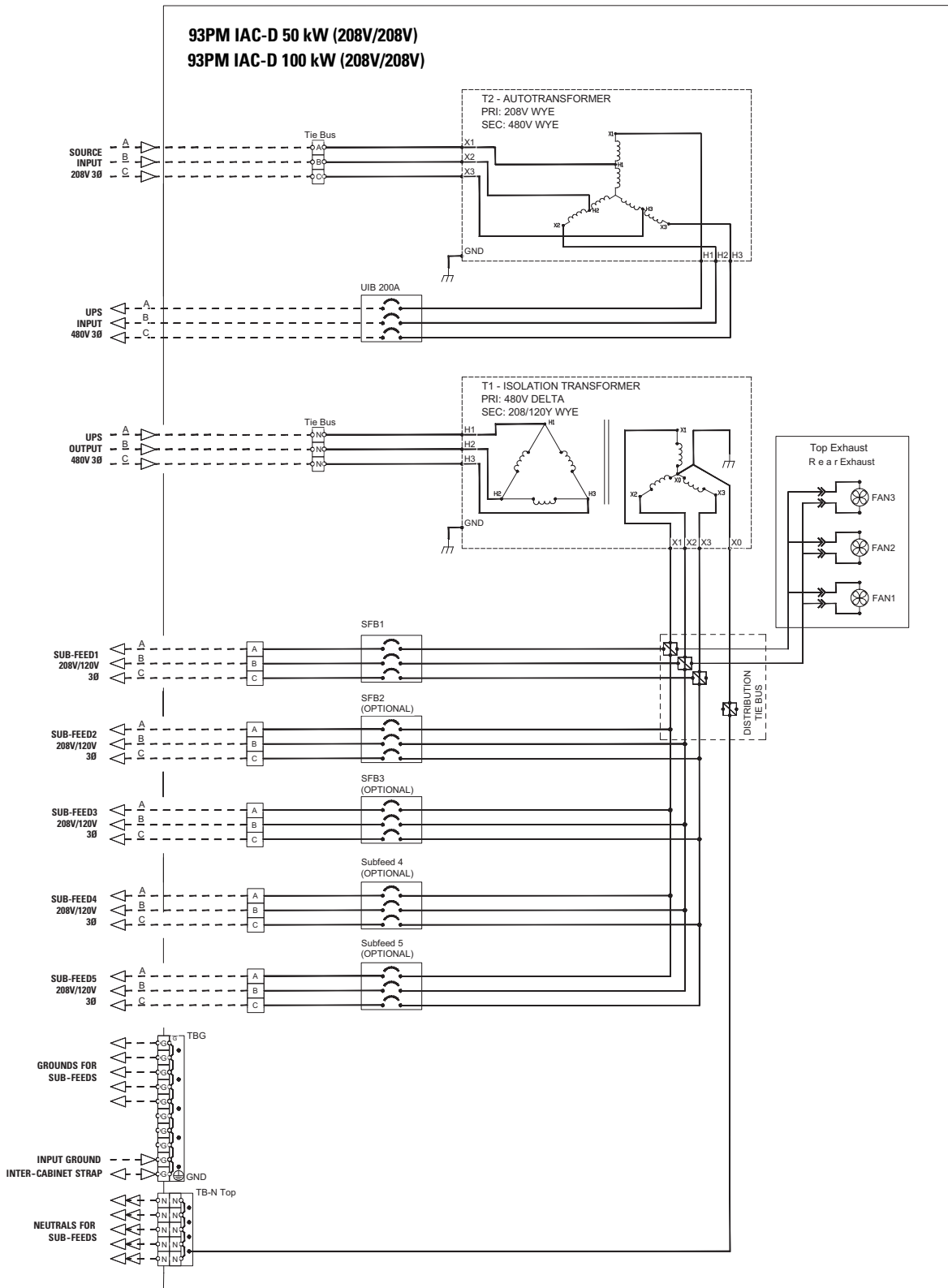

Figure 5-22. 93PM IAC-D (50 kW and 100 kW, 208V/208V) Schematic – Five 100-250A Adjustable Subfeed Breakers

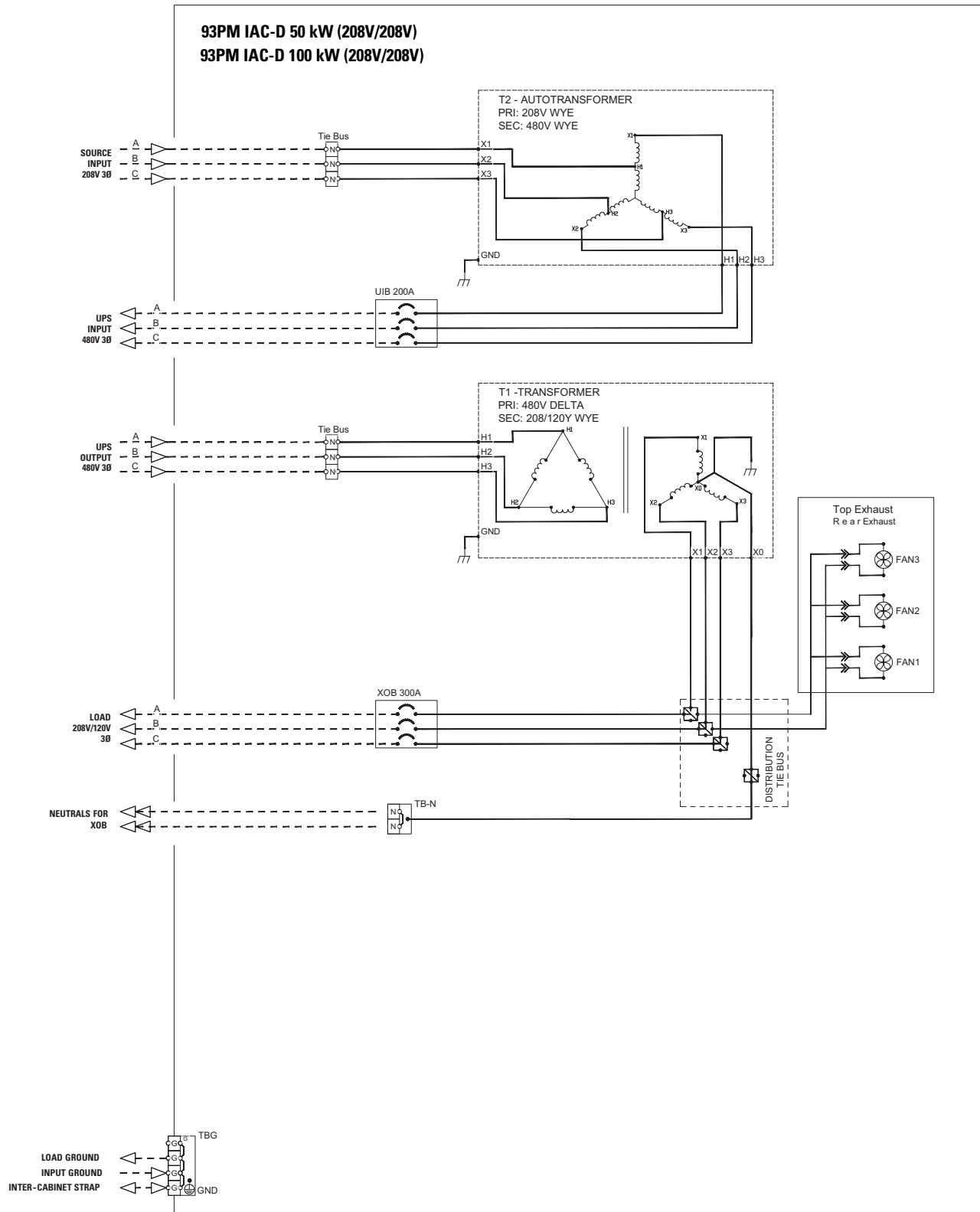

Figure 5-23. 93PM IAC-D (50 kW and 100 kW, 208V/208V) Schematic – 175A or 350A Output Breaker

This page intentionally left blank.

Chapter 6 Integrated Accessory Cabinet-Distribution Operating Instructions

This section describes how to operate the Integrated Accessory Cabinet-Distribution (IAC-D).

-
- NOTE 1** Before using the IAC-D, ensure all installation tasks are complete and a preliminary startup has been performed by authorized service personnel. The preliminary startup verifies all electrical interconnections to ensure the installation was successful and the system operates properly.
- NOTE 2** Read this section of the manual and have thorough knowledge of IAC-D operation before attempting to operate any of the controls.
-

6.1 IAC-D Breakers

Figure 6-1 through Figure 6-4 identify and show the location of the breakers on the IAC-D.

The IAC-Ds can contain the following breakers:

- **UPS Output Breaker (480V/208V IAC-D)** – Controls the 480V output from the UPS to the IAC-D
- **UPS Input Breaker (208V/208V IAC-D)** – Controls the 480V input to the UPS from the IAC-D
- **Distribution Panel Input Breaker** – Controls input to the distribution panel
- **Distribution Panel** – Provides up to 42 branch circuits per panel to distribute the output power to the loads
- **Subfeed Breakers** – Up to five optional subfeed breakers for high current loads
- **Output Breaker** – Provides a single output breaker when no distribution is required

6.2 IAC-D Operation

To operate the IAC-D:

1. Open the front door (see Figure 4-1) by lifting the latch from the bottom and turning to the right (counterclockwise) and swing the door open.
2. Verify that the IAC-D circuit breakers are set as follows:

UPS Output Breaker (only installed on 480V/208V IAC-D)	OPEN
UPS Input Breaker (only installed on 208V/208V IAC-D)	OPEN
Distribution Panel Input Breaker	OPEN
Distribution Panel Branch Breakers	OPEN
Subfeed Breakers (if installed)	OPEN
Output Breaker (if installed)	OPEN

3. If operating a 208V/208V IAC-D, close the UPS Input Breaker.
4. Start the UPS. Refer to the applicable Eaton 93PM UPS Installation and Operation manual listed in paragraph 1.7 for UPS operating procedures.
5. If operating a 480V/208V IAC-D, close the UPS Output Breaker
6. Close the distribution panel input breaker.
7. Close the distribution panel branch breakers
8. Close the subfeed breakers (if installed).
9. Close the output breaker (if installed).
10. Close the door and secure the latch.

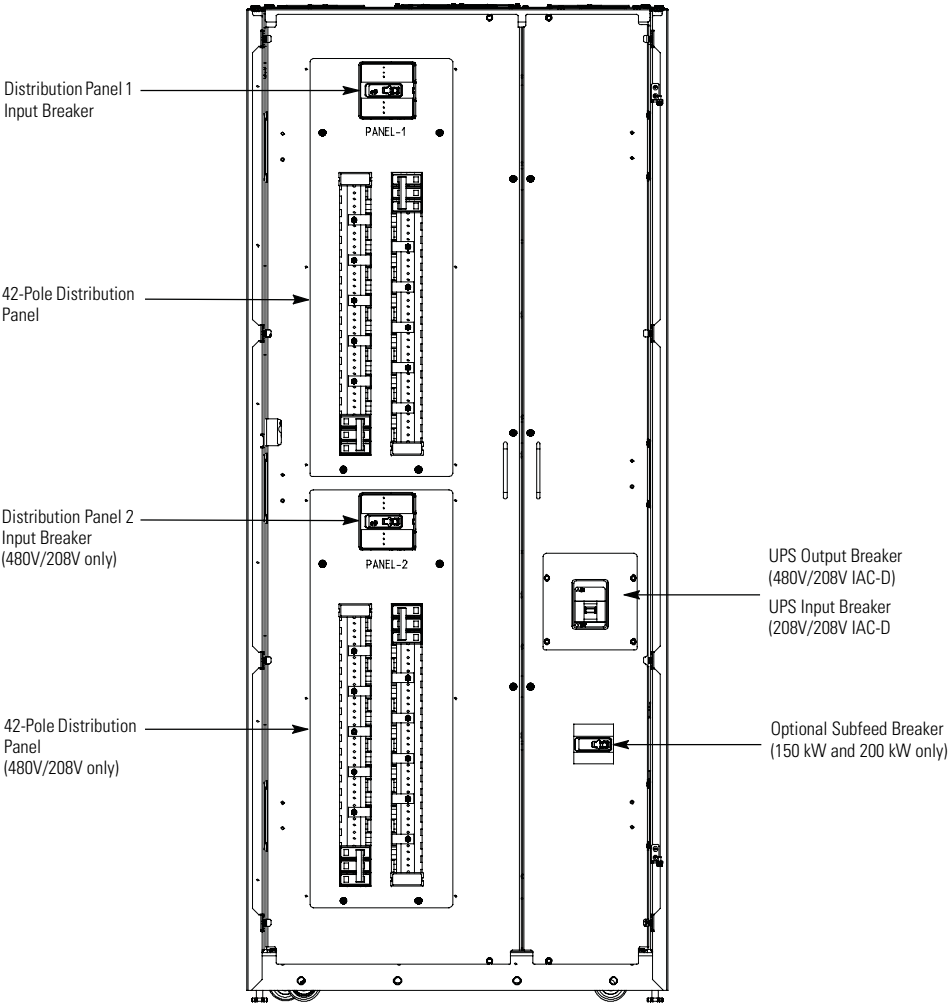

NOTE The IAC-D is shown with both top and bottom panelboards. However, the installed configuration may contain only a top or bottom panelboard.

Figure 6-1. 93PM IAC-D Breakers – Two Panelboards

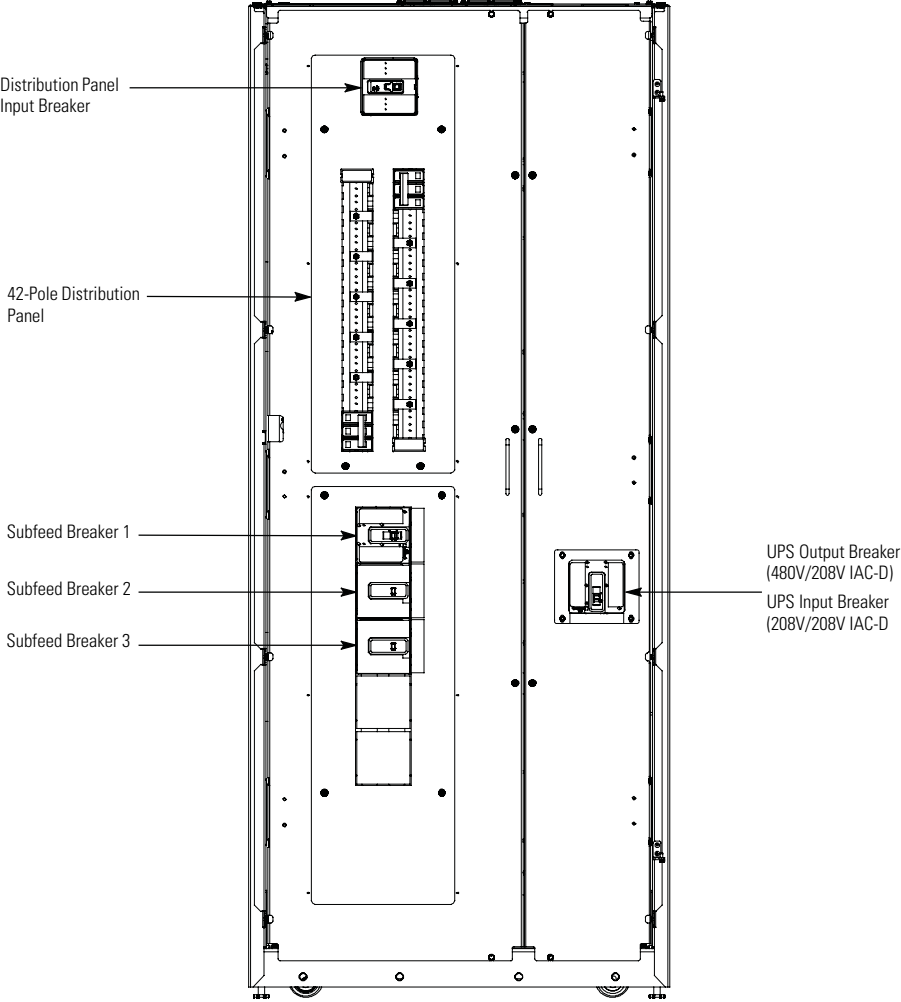

NOTE The IAC-D is shown with three 100-250A adjustable subfeed breakers. However, the installed configuration may contain one to three 100-250A adjustable subfeed breakers.

Figure 6-2. 93PM IAC-D Breakers – Top Panelboard with Subfeed Breakers

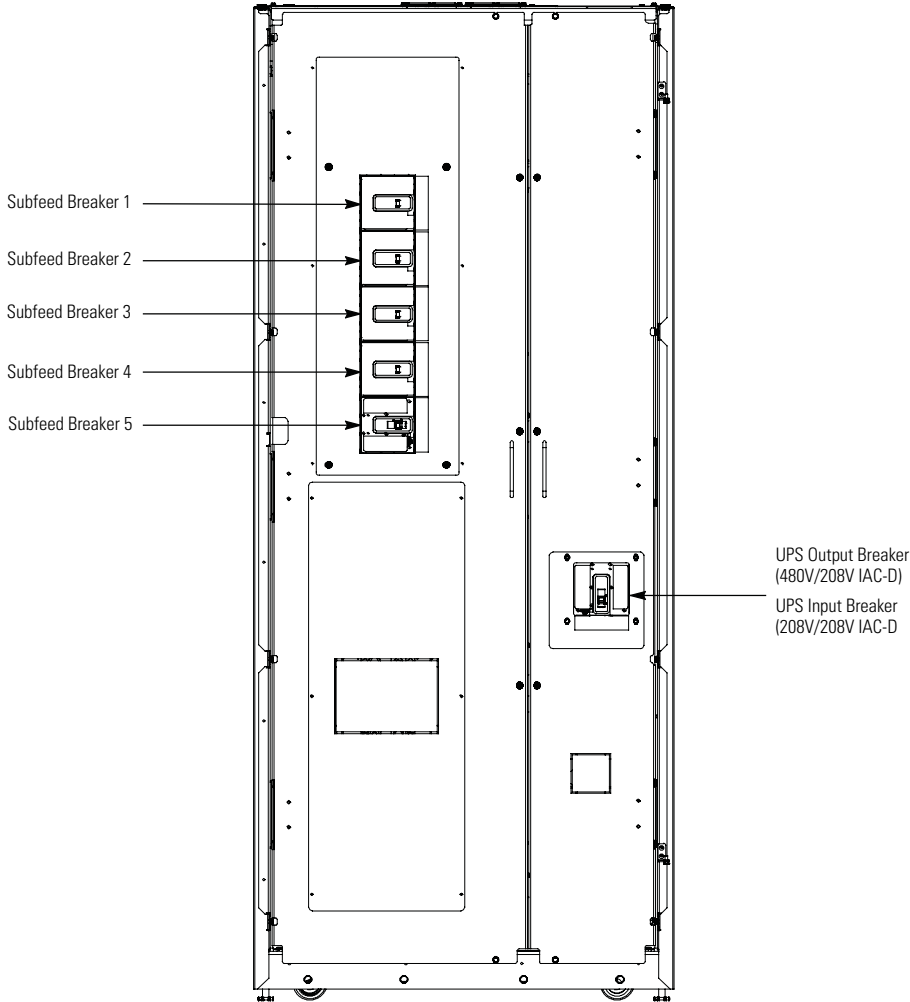

NOTE The IAC-D is shown with five 100-250A adjustable subfeed breakers. However, the installed configuration may contain one to five 100-250A adjustable subfeed breakers.

Figure 6-3. 93PM IAC-D Breakers – Subfeed Breakers

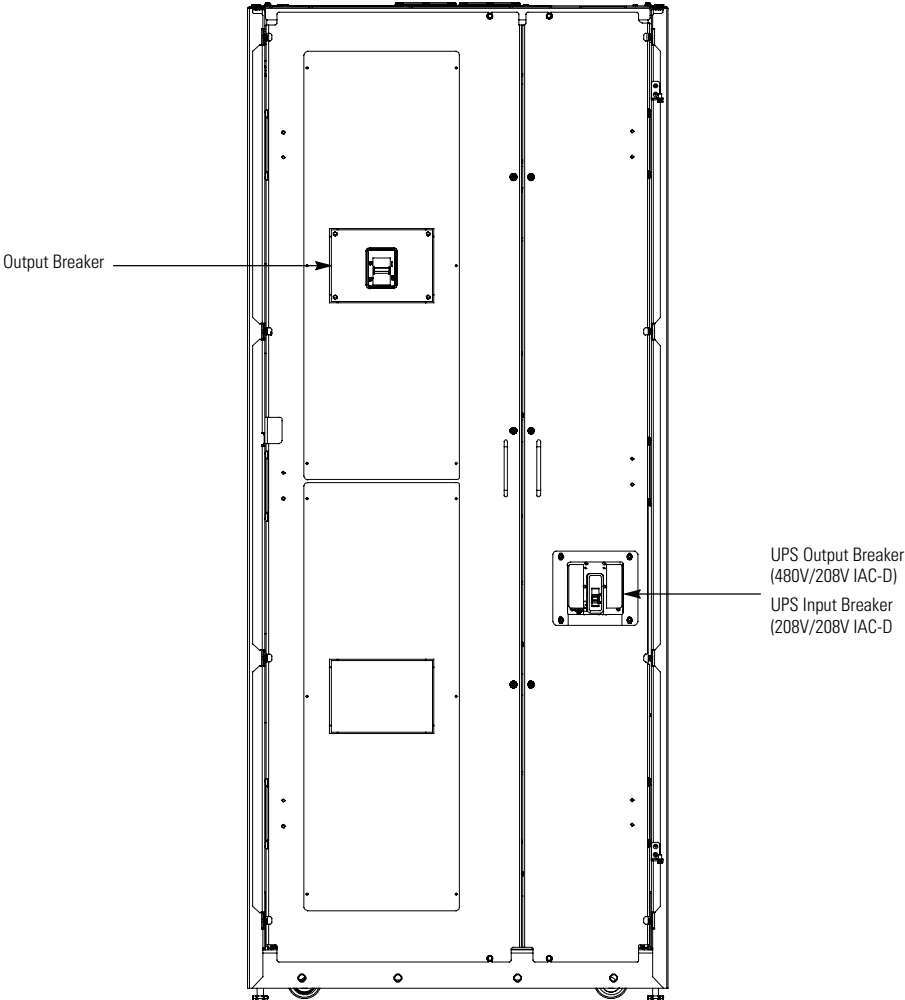

Figure 6-4. 93PM IAC-D Breakers – Output Breaker

Chapter 7 Maintenance

The components inside the IAC-D are secured to a sturdy metal frame. All repairable parts and assemblies are located for easy removal, with very little disassembly. This design allows authorized service personnel to quickly perform routine maintenance and servicing.

You must schedule periodic performance checks of the UPS system to keep it running properly. Regular routine checks of operation and system parameters enable your system to function efficiently for many trouble-free years.

7.1 Important Safety Instructions

Remember that your UPS system is designed to supply power **EVEN WHEN DISCONNECTED FROM THE UTILITY POWER.**

 **WARNING**

- No user serviceable components.
 - Servicing and maintenance should be performed by qualified service personnel only.
 - **LETHAL VOLTAGE PRESENT.** This unit should not be operated with the cabinet doors open or protective panels removed. Do not make any assumptions about the electrical state of any cabinet in the UPS system.
-

7.2 Performing Preventive Maintenance

The UPS system requires very little preventive maintenance. However, the system should be inspected periodically to verify that the units are operating normally. Record maintenance results and any corrective actions in a suitable log.

7.2.1 DAILY Maintenance

Perform the following steps daily:

1. Check the area surrounding the UPS system. Ensure the area is not cluttered, allowing free access to the unit.
2. Ensure the air intakes on the Accessory cabinets are not blocked.
3. Ensure the operating environment is within the parameters specified in paragraph 3.2.1 and Chapter 8, "Product Specifications."

7.2.2 PERIODIC Maintenance

Periodic inspections of the IAC-D should be made to determine if components, wiring, and connections exhibit evidence of overheating. Particular attention should be given to the compression lug connections. Maintenance procedures should specify that the compression lug connections be retorqued to values listed in this manual.

7.2.3 ANNUAL Maintenance

Annual preventive maintenance should be performed only by authorized service personnel familiar with maintenance and servicing of the UPS system. Contact an Eaton service representative for more information about service offerings.

7.3 Maintenance Training

A basic training course, available from Eaton, gives you a competent working knowledge of the UPS system operation and teaches you how to perform first level corrective maintenance. For more information about training and other services, contact the Help Desk (see paragraph 1.8).

This page intentionally left blank.

Chapter 8 Product Specifications

This section provides the following specifications:

- Model Numbers
- Input specifications
- Output specifications
- Environmental and safety specifications

8.1 Model Numbers

The Integrated Accessory Cabinet-Distribution (IAC-D) is available in two model to meet the needs of the Eaton 93PM UPS product line.

Integrated Accessory Cabinet-Distribution (IAC-D) Models	Description
Eaton 93PM 50 kW IAC-D (480V/208V)	IAC-D for Eaton 93PM 50 kW UPS Frame
Eaton 93PM 50 kW IAC-D (208V/208V)	
Eaton 93PM 100 kW IAC-D (480V/208V)	IAC-D for Eaton 93PM 100 kW UPS Frame
Eaton 93PM 100 kW IAC-D (208V/208V)	
Eaton 93PM 150 kW IAC-D (480V/208V)	IAC-D for Eaton 93PM 150 kW UPS Capacity Frame
Eaton 93PM 200 kW IAC-D (480V/208V)	IAC-D for Eaton 93PM 200 kW UPS Frame

8.2 Specifications

The following sections detail the input, output, and environmental and safety specifications for the IAC-D.

8.2.1 Input

Operating Input Voltage Range	With 208V/480V Input Transformer – 208V nominal (60Hz) or Without 208V/480V Input Transformer – 480V nominal (60 Hz)
Input Wiring: 3W + G Operating Frequency Range	60 Hz \pm 5 Hz
Operating Input Current	See Table 3-4 or Table 3-5

8.2.2 Output

Operating Output Voltage	208/120 Vac nominal
Output Wiring: 4W + G Operating Output Frequency Range	60 Hz \pm 5 Hz
Output Current	See Table 3-6 or Table 3-7

8.2.3 Environmental and Safety Specifications

Operating Temperature	41°F to 104°F (5°C to 40°C).
Transit Temperature	-13°F to 140°F (-25°C to 60°C)
Storage Temperature	-13°F to 131°F (-25°C to 55°C)
Operating Altitude	Maximum 1500m (5000 ft) at 40°C without derating
Transit Altitude	15000m (49213 ft)
Ventilation	<p>50 kW: Natural convection air cooling for rear exhaust Natural convection air cooling for top exhaust</p> <p>50 kW with 208V/480V input transformer: Forced air cooling for top exhaust Forced air cooling for rear exhaust</p> <p>100 kW: Natural convection air cooling for rear exhaust Forced air cooling for top exhaust</p> <p>100 kW with 208V/480V input transformer: Forced air cooling for top exhaust Forced air cooling for rear exhaust</p> <p>150 kW: Forced air cooling for rear exhaust Forced air cooling for top exhaust</p> <p>200 kW: Forced air cooling for rear exhaust Forced air cooling for top exhaust</p>
Relative Humidity (operating and storage)	95%, noncondensing
Acoustical Noise	Not applicable
Safety Conformance	UL1778 4 th edition
Agency Markings	cULus
EMC (Class A)	FCC Part 15 Class A and 62040-2 c3

Warranty

Limited Factory Warranty for Three-Phase Eaton 93PM UPS and 93PM UPS Accessory Products

WARRANTOR: The warrantor for the limited warranties set forth herein is Eaton, ("Eaton").

LIMITED WARRANTY: This limited warranty (this "Warranty") applies only to the original end-user (the "End-User") of the Eaton Three-Phase 93PM UPS and 93PM UPS Accessory Products (the "Product") and cannot be transferred. This restriction applies even in the event that the Product is initially sold by Eaton for resale to an End-User. This Warranty gives you specific legal rights, and you may also have other rights which vary from State to State (or jurisdiction to jurisdiction).

WHAT THIS LIMITED WARRANTY COVERS: The warrantor warrants, with the terms of this Warranty, that the Eaton three-phase UPS electronics, Eaton-built accessories, and Eaton-built battery cabinets (individually and collectively, the "Warranted Items") are free from defects in material and workmanship.

For Product installed (and currently located) in the fifty (50) United States and the District of Columbia, if, in the opinion of Eaton, a Warranted Item is defective, Eaton's sole obligation, at the option of Eaton, will be to refurbish or replace such defective Warranted Item (including the costs of providing diagnosis, service, and labor ["labor coverage"]). The defective Warranted Item will be refurbished or replaced onsite at the End-User's location or such other location as determined by Eaton. Any parts that are replaced may be new or reconditioned. All parts replaced by Eaton shall become the property of Eaton.

For Product installed (and currently located) outside the fifty (50) United States and the District of Columbia, if, in the opinion of Eaton, a Warranted Item is defective, Eaton's sole obligation, at the option of Eaton, will be to refurbish or replace such defective Warranted Item (not including the costs of labor coverage). The defective Warranted Item will be refurbished or replaced onsite at the End-User's location or such other location as determined by Eaton. Any parts that are replaced may be new or reconditioned. All parts replaced by Eaton shall become the property of Eaton.

LIMITED WARRANTY PERIOD: The period covered by this Warranty for Product installed (and currently located) in the fifty (50) United States and the District of Columbia is six (6) months from the date of Product purchase for labor coverage when no startup is performed by an authorized Eaton Customer Service Engineer or Agent or twelve (12) months from the date of Product purchase with startup performed by an authorized Eaton Customer Service Engineer or Agent and twelve (12) months from the date of Product purchase or eighteen (18) months from date of Product shipment, whichever occurs first, for the refurbishment/ replacement of parts.

The period covered by this Warranty for Product installed (and currently located) outside the fifty (50) United States and the District of Columbia is twelve (12) months from the date of Product purchase or eighteen (18) months from the date of Product shipment, whichever occurs first, for the refurbishment/replacement of parts.

WHAT THIS LIMITED WARRANTY DOES NOT COVER: This Warranty does not cover any defects or damages caused by: (a) failure to properly store the Product before installation, including the "trickle charge" of batteries no later than the date indicated on the packaging; (b) shipping and delivery of the Product if shipping is FOB Factory; (c) neglect, accident, fire, flood, lightning, vandalism, acts of God, Customer's neglect, abuse, misuse, misapplication, incorrect installation; (d) repair or alteration not authorized in writing by Eaton personnel or performed by an authorized Eaton Customer Service Engineer or Agent; or (e) improper testing, operation, maintenance, adjustment, or any modification of any kind not authorized in writing by Eaton personnel or performed by an authorized Eaton Customer Service Engineer or Agent.

This Warranty is not valid: if the Product's serial numbers have been removed or are illegible. Any Warranted Items repaired or replaced pursuant to this Warranty will be warranted for the remaining portion of the original Warranty subject to all the terms thereof. Eaton does not provide a labor warranty for Product located outside of the fifty (50) United States or the District of Columbia. **Any equipment, parts, or materials included in the Product and not manufactured by Eaton are warranted solely by the manufacturer of such equipment, parts, or materials and are not included as part of this Warranty. Batteries are not warranted by Eaton.**

THIS WARRANTY IS THE END-USER'S SOLE REMEDY AND IS EXPRESSLY IN LIEU OF, AND THERE ARE NO OTHER, EXPRESSED OR IMPLIED GUARANTEES OR WARRANTIES (INCLUDING ANY IMPLIED WARRANTY OF MERCHANTABILITY OR FITNESS FOR ANY PURPOSE, WHICH ARE EXPRESSLY DISCLAIMED). SOME STATES OR JURISDICTIONS DO NOT ALLOW THE EXCLUSION OF EXPRESS OR IMPLIED WARRANTIES, SO THE ABOVE EXCLUSION MAY NOT APPLY TO YOU. IN THAT EVENT, SUCH WARRANTIES ARE LIMITED IN DURATION TO THE LIMITED WARRANTY PERIOD. SOME STATES OR JURISDICTIONS DO NOT ALLOW LIMITATIONS ON HOW LONG AN IMPLIED WARRANTY LASTS OR THE EXCLUSION OR LIMITATION OF INCIDENTAL OR CONSEQUENTIAL DAMAGES, SO THE ABOVE LIMITATIONS AND/OR EXCLUSIONS MAY NOT APPLY TO YOU.

LIMITATION OF LIABILITY: In no event shall Eaton be liable for any indirect, incidental, special or consequential damages of any kind or type whatsoever, resulting from or in connection with any claim or cause of action, whether brought in contract or in tort (including negligence and strict liability). Some States or jurisdictions do not allow the exclusion of limitation of incidental or consequential damages, so the above limitation or exclusion may not apply to you. Eaton shall not be responsible for failure to provide service or parts due to causes beyond Eaton's reasonable control. In no case will Eaton's liability under this Warranty exceed the replacement value of the Warranted Items.

END-USER'S OBLIGATIONS: In order to receive the benefits of this Warranty, the End-User must register the product warranty (via mail or online at www.powerquality.eaton.com/Product-Registration "product registration"); use the Product in a normal way; follow the Product's user's guide; and protect against further damage to the Product if there is a covered defect.

OTHER LIMITATIONS: Eaton's obligations under this Warranty are expressly conditioned upon receipt by Eaton of all payments due to it (including interest charges, if any). During such time as Eaton has not received payment of any amount due to it for the Product, in accordance with the contract terms under which the Product is sold, Eaton shall have no obligation under this Warranty. Also during such time, the period of this Warranty shall continue to run and the expiration of this Warranty shall not be extended upon payment of any overdue or unpaid amounts.

COSTS NOT RELATED TO WARRANTY: The End-User shall be invoiced for, and shall pay for, all services not expressly provided for by the terms of this Warranty, including without limitation site calls involving an inspection that determines no corrective maintenance is required. Any costs for replacement equipment, installation, materials, freight charges, travel expenses, or labor of Eaton representatives outside the terms of this Warranty will be borne by the End-User.

OBTAINING WARRANTY SERVICE: In the USA, call the Eaton Customer Reliability Center 7x24 at 800-843-9433. Outside of the USA, call your local Eaton sales or service representative, or call the Eaton Customer Reliability Center in the United States at 919-845-3633. For comments or questions about this Limited Factory Warranty, write to the Customer Quality Representative, 8609 Six Forks Road, Raleigh, North Carolina 27615 USA.



P-164000229 8