

MITSUBISHI ELECTRIC POWER PRODUCTS, INC.

UNINTERRUPTIBLE POWER SUPPLY SYSTEM

2033D SERIES

OWNERS / TECHNICAL MANUAL

Revision 1.5: Aug. 22, 2007
ALN-H0963

Preface

TABLE OF CONTENTS

LIST OF TABLES	iii
LIST OF FIGURES	iv
HOW TO USE THIS MANUAL	v
1.0 INTRODUCTION	1-1
1.1 GENERAL	1-3
1.2 DEFINITIONS	1-4
1.3 OVERVIEW	1-5
1.4 SPECIFICATIONS	1-11
2.0 OPERATOR CONTROLS AND INDICATORS	2-1
2.1 LED DISPLAY	2-2
2.2 MBP LAMP	2-2
2.3 EPO BUTTON	2-2
2.4 LIQUID CRYSTAL DISPLAY	2-3
2.5 EXTERNAL SIGNAL TERMINAL BLOCK	2-8
2.6 EXTERNAL COMMUNICATION CONNECTOR	2-13
3.0 INSTALLATION AND OPERATION	3-1
3.1 TRANSPORTATION AND INSTALLATION	3-1
3.2 INSTALLATION PROCEDURE	3-1
3.3 PROCEDURE FOR CABLE CONNECTIONS	3-3
3.4 OPERATING PROCEDURES FOR SINGLE MODULE SYSTEM	3-12
3.5 INTERNAL MAINTENANCE BYPASS SET-UP PROCEDURES..... FOR SINGLE MODULE SYSTEM	3-14
3.6 OPERATING PROCEDURES FOR MULTI MODULE SYSTEM.....	3-15
4.0 RESPONSE TO UPS FAILURE	4-1
5.0 PARTS REPLACEMENT	5-1
6.0 FAULT CODES	6-1
7.0 WARRANTY & OUT OF WARRANTY SERVICE	7-1

List of Tables

Table 1.1	Power Specifications.....	1-11
Table 1.2	UPS Module Information.....	1-11
Table 1.3	Detail of Specifications	1-12
Table 1.4	Rating of Contactor and Fuses.....	1-13
Table 3.1	How to Transport and Install the System	3-1
Table 3.2	List of UPS Weights (lb.).....	3-1
Table 3.3	Type and number of Battery	3-2
Table 3.4	Maximum Permitted Fault Current.....	3-3
Table 3.5	Recommended Cable Size and Torque Requirements.....	3-5
Table 3.6	Crimp Type Compression Lug.....	3-6
Table 6.1	Fault Code.....	6-2

List of Figures

Figure 1.1	Single Line Diagram-Normal Operation.....	1-5
Figure 1.2	Single Line Diagram-Bypass Operation	1-6
Figure 1.3	Single Line Diagram-Battery Operation.....	1-7
Figure 1.4	UPS Parts Location.....	1-8
Figure 1.5	UPS Parts Location (Continued)	1-9
Figure 1.6	External I/F circuit PCB IOAU-05	1-9
Figure 2.1	Operation/Display Panel	2-1
Figure 2.2	Main Screen.....	2-3
Figure 2.3	Start/Stop Screen.....	2-4
Figure 2.4	PIN Protection Screen	2-4
Figure 2.5	Bypass Voltage Abnormal Message Screen	2-4
Figure 2.6	Measurement Screen.....	2-4
Figure 2.7	Setup Screen	2-5
Figure 2.8	Log Select Screen.....	2-5
Figure 2.9	Event Log Screen	2-5
Figure 2.10	Battery Log Screen	2-6
Figure 2.11	Main Screen (Battery Operation)	2-6
Figure 2.12	Measurement Screen (Battery Operation)	2-6
Figure 2.13	Main Screen (Fault Indication)	2-7
Figure 2.14	Message Screen	2-7
Figure 2.15	External Signal Terminal Block.....	2-8
Figure 2.16	Control Wiring for External Contacts	2-10
Figure 2.17	Remote "Start" Contact Connections	2-11
Figure 2.18	External communication connector	2-13
Figure 3.1	UPS Terminal Designation	3-7
Figure 3.2	Diagram of input/output bus bars and terminal blocks	3-8
Figure 3.3	Diagram of Power Wire Connect (Parallel Connection)	3-10
Figure 3.4	Diagram of Power Wire & Control Wire Connect (Parallel Connection) ..	3-11

How to use this Manual

This manual is designed for ease of use, giving the user easy and quick reference to information.

This manual uses notice icons to draw attention to the user important information regarding the safe operation and installation of the UPS. The notice icons used in this manual are explained below, and should be taken into account and adhered to whenever they appear in the text of this manual.



Warning: A warning notice icon conveys information provided to protect the user and service personnel against hazards and/or possible equipment damage.



Caution: A caution notice icon conveys information provided to protect the user and service personnel against possible equipment damage.



Note: A Note notice icon indicates when the user should make a reference of information regarding the UPS operation, load status and display status. Such information is essential if Mitsubishi field service group assistance and correspondence is required.

Safety Recommendations: If any problems are encountered while following this manual, Mitsubishi field service group assistance and correspondence is recommended.

1.0 INTRODUCTION

Your Mitsubishi Uninterruptible Power Supply System (UPS) is designed to provide many years of reliable protection from power failure, brownouts, line noise, and voltage transients. To ensure optimum performance of the equipment, follow the manufacturer's instructions. This manual contains descriptions required to operate the UPS. Please read this manual carefully and retain it for future reference.

**IMPORTANT SAFETY INSTRUCTIONS
RETAIN THESE INSTRUCTIONS**



This manual contains important instructions for the 2033D Series Uninterruptible Power Supply System that should be followed during installation and maintenance of the UPS and batteries.

WARNING 1



Lethal voltages exist within the equipment during operation. Observe all warning and cautions in this manual. Failure to comply may result in serious injury or death. Obtain qualified service for this equipment as instructed.

WARNING 2

This UPS does not include a Bypass input circuit breaker (MCCB) to protect bypass circuit. Bypass input circuit breaker (MCCB) are to be field supplied and installed. Recommended Breaker (MCCB)'s Specifications are as follows:

Capacity (kVA)	Bypass Voltage (Vac)	Bypass Rating (Aac)	Recommended Breaker (Aac)
30	480	36	50
50	480	60	80
80	480	96	125

AC input and AC output over current protection and disconnect devices shall be field supplied and installed. DC output over current protection and disconnect device shall be field supplied and installed. The over current protection device shall be rated as indicated in TABLE 1.4.

1.1 GENERAL

The Mitsubishi 2033D Series UPS is designed to provide continuous and clean electrical power to a critical load. Additionally the UPS monitors power conditions affecting the load. In the event of an input power failure, the UPS will supply power to the critical load for the specified battery time.

If the input power is not restored promptly, back up power from the UPS battery permits the orderly shutdown of equipment supported by the UPS. The UPS is simple to start-up, operate and maintain.

The 2033D Series UPS is available in three (3) kVA sizes-30, 50 and 80kVA, and also in two (2) output voltages - 208V and 480V. Specifications for each kVA and voltage model appear in Section 1.4. 30kVA model has batteries included in the UPS module cabinet. 50 and 80kVA models have external batteries. The principles of operation described herein are applicable to all models.

This manual provides an overview of the 2033D Series components and their functions. The appearance and purpose of operator controls and indicators is described with procedures for operation, start-up, shutdown and basic maintenance included.

1.2 Definitions

UNINTERRUPTIBLE POWER SUPPLY SYSTEM (UPS) - All components within the UPS Module Cabinet and associated batteries that function as a system to provide continuous, conditioned AC power to a load. This is sometimes referred to as the "System".

UPS MODULE CABINET - The metal enclosure which contains the Converter, the Inverter, the Chopper, the Static Transfer Switch, the Internal Bypass line, the operator controls, and the internal control system required to provide specified AC power to a load.

UPS MODULE - The Converter and Inverter assemblies which, under the direction of the internal control system and operator controls, provide specified AC power to a load.

CONVERTER/BOOSTER - The UPS components which contain the equipment and controls necessary to convert input AC power to regulated DC power required for battery charging and for supplying power to the Inverter.

INVERTER - The UPS components that contain the equipment and controls necessary to convert DC power from the Converter, or the battery, to AC power required by the critical load.

CHOPPER - The UPS components which contain the equipment and controls necessary to charge the battery and supply power to the Inverter from battery.

STATIC TRANSFER SWITCH - The device which connects the critical load to the bypass line when the UPS module cannot supply continuous power.

BYPASS LINE - The line which conducts electricity directly from the input power source to the critical load during Maintenance or whenever the UPS is not completely operational.

INPUT POWER - Power provided by the electrical utility company, or auxiliary generator, which is connected to the UPS for supplying the critical load.

BATTERY - The rechargeable battery strings that supply DC power to the inverter to maintain continuous AC power to the load during AC input power failure conditions

1.3 Overview

The UPS provides two power paths between the utility source and the critical load.

Figure 1.1 shows the path for normal operation, with the load powered from the inverter.

Figure 1.2 shows the path for bypass operation, with the load supplied through the static bypass line.

Figure 1.3 shows the path for battery operation, with the load supplied from the inverter.

A) Normal Operation.

FIGURE 1.1 Single Line Diagram - Normal Operation. Load powered by inverter

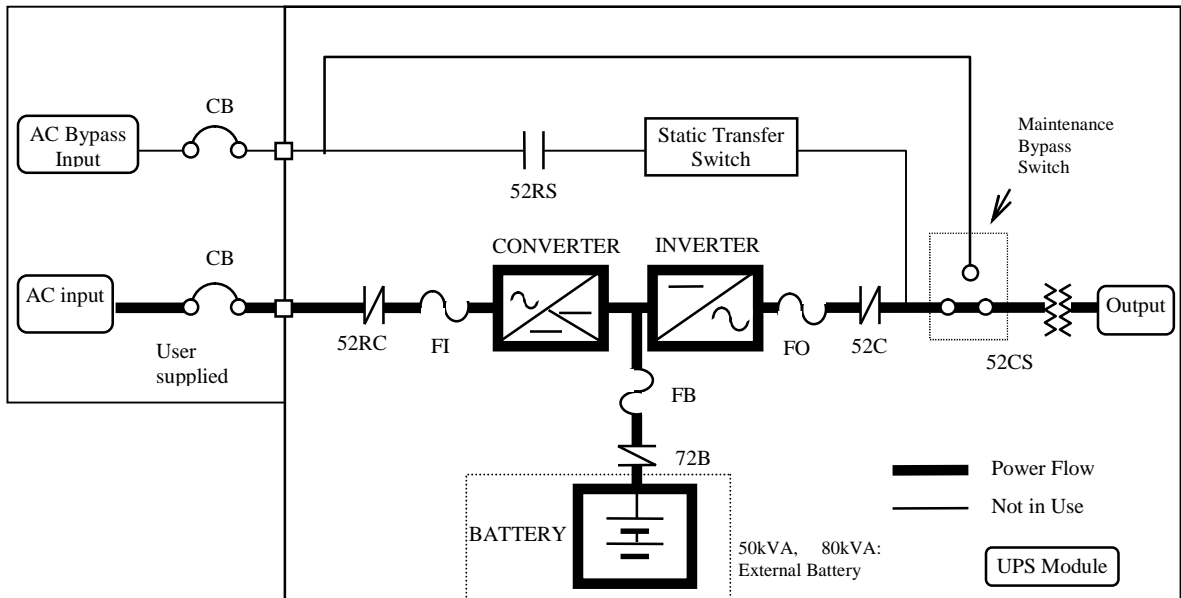

During normal operation, the path through the inverter is used to power the load.

Referring to Figure 1.1: Input AC power is converted to DC by the Converter. DC power is utilized to charge the UPS battery and to provide power to the Inverter. The Inverter converts the DC power to clean AC power to supply the critical load.

The conversion - inversion process eliminates any voltage transients or fluctuations existing in the input power before it reaches the critical load.



* The AC Bypass Input circuit breaker (MCCB) for protection of the UPS and cables are field supplied and field installed. (See WARNING 2 on page 1-2)

B) Internal Static Bypass Line

FIGURE 1.2 Single Line Diagram- Bypass Operation. Load fed through static bypass line.

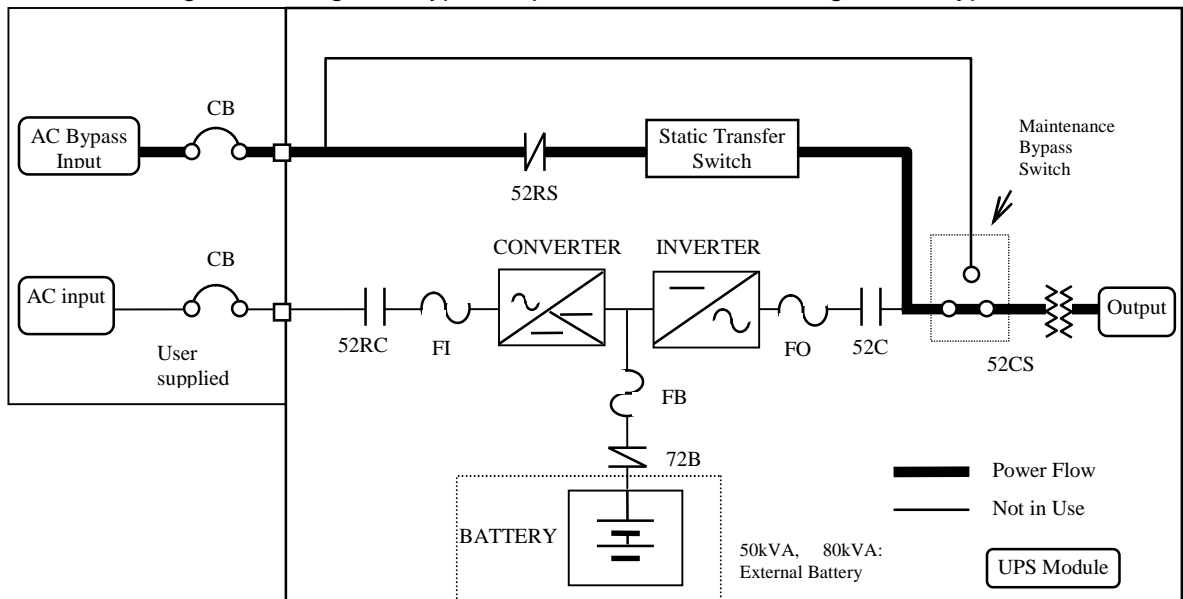

Referring to Figure 1.2, the Internal Static Bypass line is a Hard wired line through Static Transfer Switch which supplies the critical load with unconditioned input power. The purpose of this line is to route power to the critical load while the UPS module is de-energized during Start-up before the system is fully operational.

The internal control system determines the operation of the two paths, with the load powered from the inverter being the normal operation.

C) Inverter supply at battery operation

FIGURE 1.3 Single Line Diagram - Battery Operation

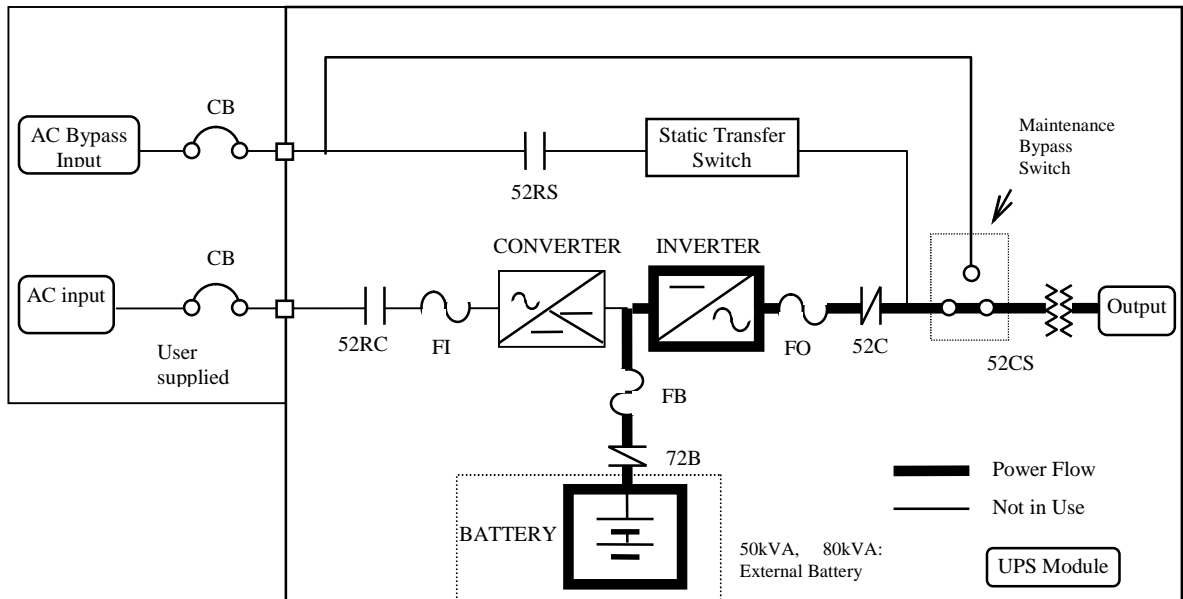

Referring to Figure 1.3: In the event of AC input source failure or interruption, the converter will de-energize and the battery will immediately discharge and supply DC power to the inverter to maintain continuous AC power to the load. This operation will continue until:

- a) The battery capacity expires and the inverter turns off, or
- b) Input power is restored after which the converter will power the inverter and critical load and simultaneously recharge the batteries.

A fully charged battery will provide power for the specified time at the rated load, or longer, at a reduced load.

When power is restored after a low battery shutdown, the converter automatically restarts operation, recharges the batteries and the Inverter is automatically restarted without operator intervention. Load is automatically assumed by the inverter without operator intervention.

The power drawn by the load is equally shared between all system UPS during battery operation.

FIGURE 1.4-a UPS Parts Location (30kVA)

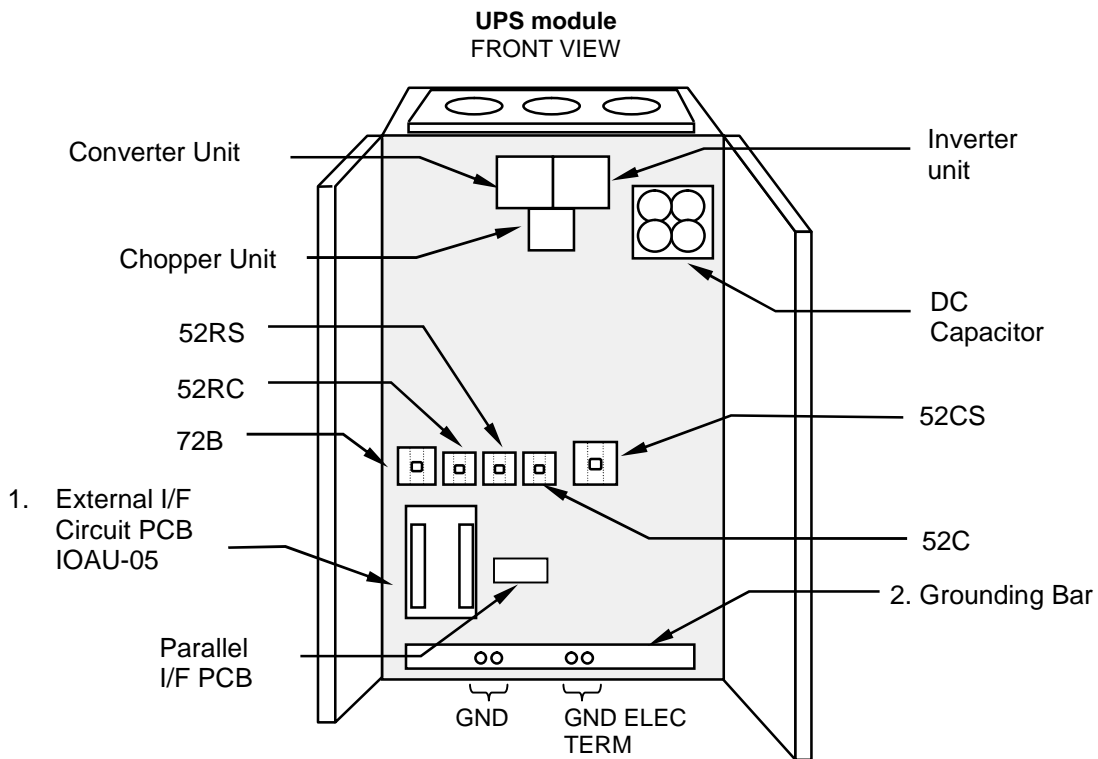

FIGURE 1.4-b UPS Parts Location (50kVA, 80kVA)

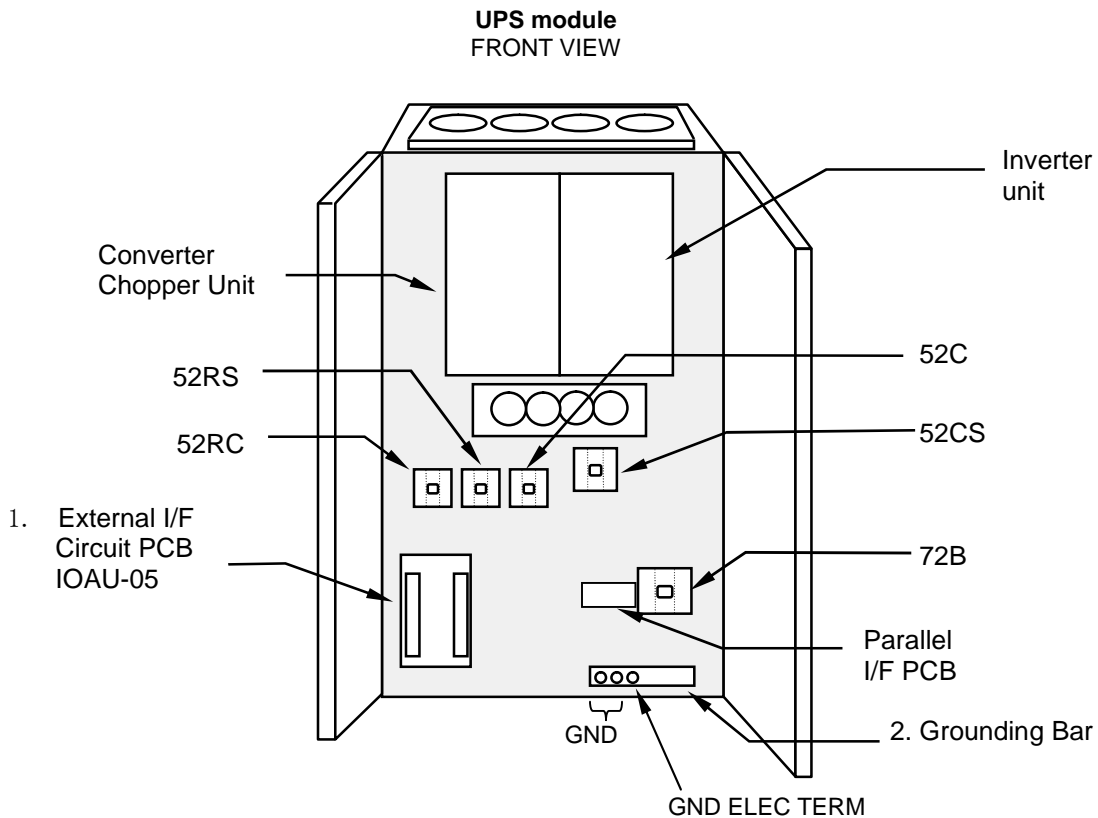

FIGURE 1.5 UPS Parts Location (Continued)

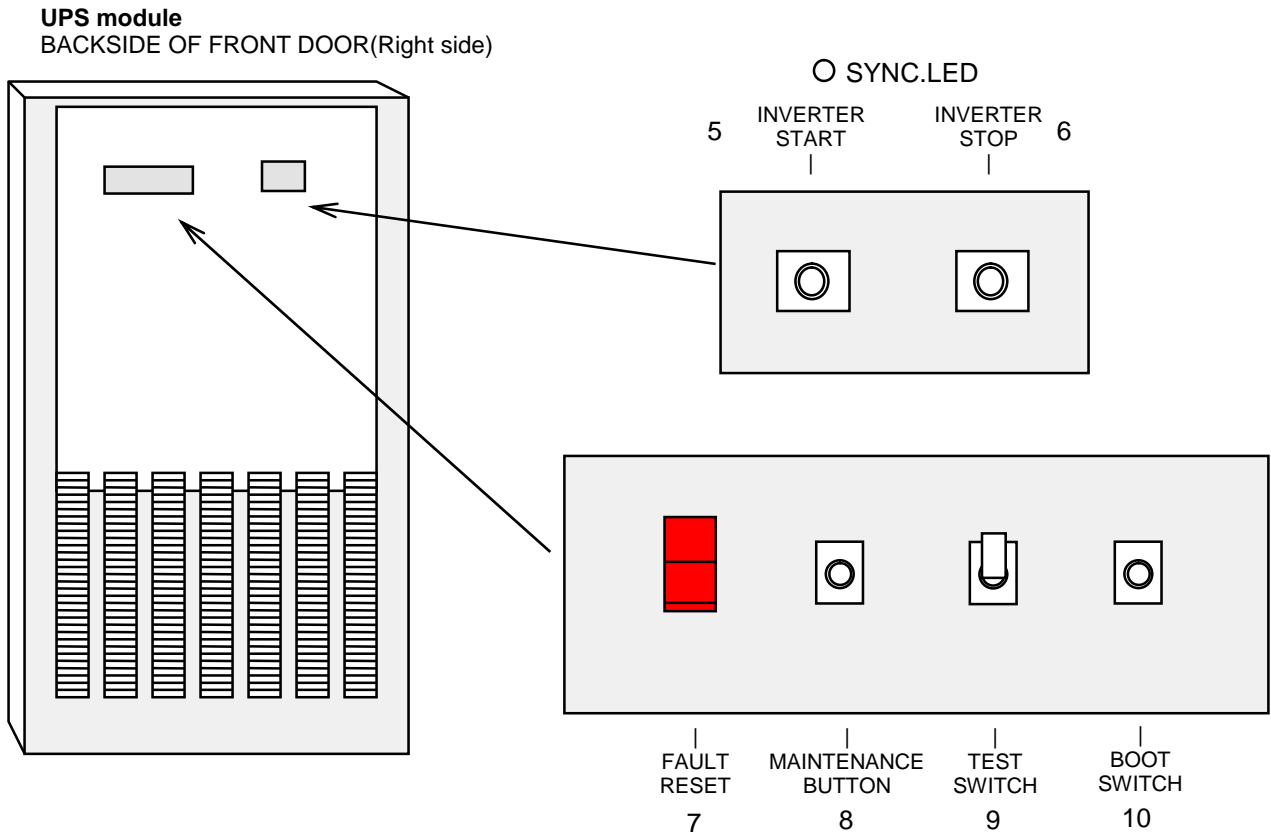
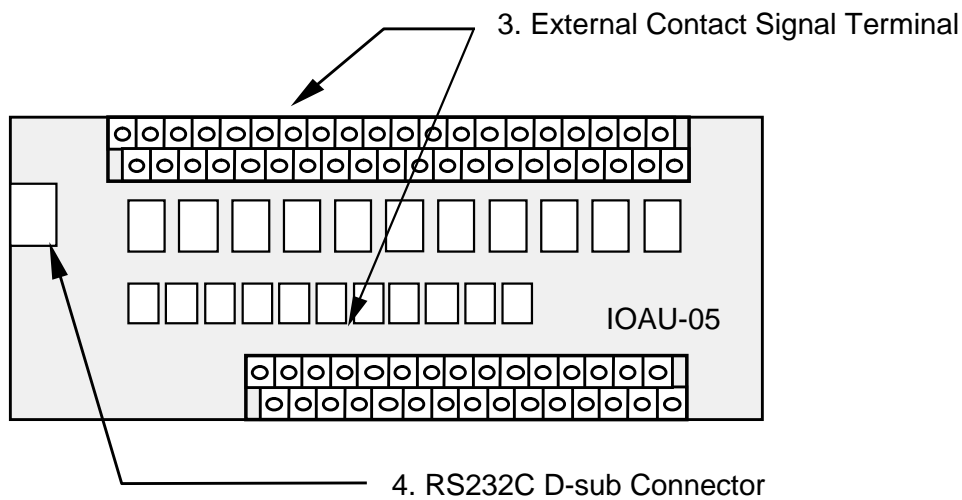

FIGURE 1.6 External I/F PCB IOAU-05



Description of Figures 1.4, 1.5, and 1.6:

1. **External I/F Board (IOAU-05) : FOR SERVICE PERSONNEL ONLY (FIGURE 1.6):**
 - (3) External contact signal terminal
 - (4) RS232C communication connector
2. **Grounding Bar (E)**
3. **External Contact Signal Terminal Block** - Terminal block to connect contact signal input/output lines to and from the external devices. Refer to Figure 2.15 section 2.5 for details.
4. **RS232C Communication Connector** - Refer to Figure 2.18 section 2.6 for details.
5. **“INVERTER” START Switch** - This switch is used to transfer the UPS from static bypass to inverter during maintenance purposes. Transfers will lock-out if the bypass voltage is more than +10%,-10% of nominal.
** Uninterrupted switching is made at the time of synchronous operation. Switching is impossible at the time of asynchronous operation.*
6. **“INVERTER STOP” Switch** - This switch is used to transfer the UPS from inverter to static bypass during maintenance purposes. Do not operate it under normal operation. Transfers will lock-out if the bypass voltage is more than +10%,-10% of nominal.
** Uninterrupted switching is made at the time of synchronous operation. Switching is impossible at the time of asynchronous operation.*
7. **“FAULT RESET” Switch (FOR SERVICE PERSONNEL ONLY)** - This switch resets errors resulting from alarm conditions. (Do not operate this switch while inverter and converter are in operation.)
8. **Maintenance (Set) Button (FOR SERVICE PERSONNEL ONLY)** - This switch sets the UPS menu parameters.
9. **“Test mode” Switch (FOR SERVICE PERSONNEL ONLY)** - This switch changes system operation to the test-mode. (This switch should not be operated by personnel other than an Authorized Service Engineer).
10. **“BOOT” Switch (FOR SERVICE PERSONNEL ONLY)** - This switch boots the processor in the main control circuit resulting from alarm conditions. (Do not operate this switch while inverter and converter are in operation).

1.4 Specifications

The UPS name plate displays the rated kVA as well as nominal voltages and currents. The name plate is located on the inside of the UPS front door.

TABLE 1.1 Power Specifications

Rated output Power	Input voltage 3 phase / 3 wire	Bypass input voltage 3 phase / 3 wire	Output voltage 3 phase / 3 or 4 wire
30kVA / 24kW	480V	480V	208V or 480V
50kVA / 40kW	480V	480V	208V or 480V
80kVA / 64kW	480V	480V	208V or 480V

TABLE 1.2 UPS Module Information

UPS [kVA]	CABLE ENTRY	WIDTH [in / mm]	DEPTH [in / mm]	HEIGHT [in / mm]	WEIGHT [lb./ kg]	HEATING [kBTU/h]
30	BOTTOM	33.9 / 860	31.5 / 800	70.9 / 1800	2060 / 930	9.1
50	BOTTOM	33.9 / 860	31.5 / 800	70.9 / 1800	1580 / 715	13.5
80	BOTTOM	33.9 / 860	31.5 / 800	70.9 / 1800	1990 / 900	21.6

TABLE 1.3 Detail of Specifications

Rated Output kVA	30	50	80
Rated Output kW	24	40	64
AC INPUT			
Configuration	3 phase, 3 wire		
Voltage	480 V +15% to -15% (-30% can be operated)		
Frequency	60 Hz (45.4Hz to 65Hz)		
Reflected Current THD	4% typ. at 100% load; 7% typ. at 50% load		
STATIC BYPASS INPUT			
Configuration	3 phase, 3 wire		
Voltage	480 V +/-10%		
Frequency	60 Hz		
BATTERY			
Type	Lead Acid		
Ride Through	Application Specific		
Nominal Voltage	480 Vdc		
Minimum Voltage	401 Vdc		
Number of Cells	240		
AC OUTPUT			
Configuration	3 phase, 4 wire		
Voltage	120/208 V, 277/480 V		
Voltage Stability	+/-1%		
Frequency	60 Hz		
Frequency Stability	+/-0.05% in free running mode		
Power Factor	0.8 nominal		
Power Factor range	0.8 - 1.0 lagging (within output kW rating)		
Voltage THD	2% typical THD at 100% Linear Load 5% typical THD at 100% non-linear load		
Transient Response	+/-3% at 100% load step +/-1% at loss/return of AC power +/-3% at load transfer to/from static bypass		
Transient Recovery	16.6ms		
Inverter Overload	125% for 10 minutes, 150% for 1 minute		
System Overload	1000% for 1 cycle (with bypass available)		
Bypass Overload	150% for 1 minute		
ENVIRONMENTAL			
Cooling	Forced Air		
Operating Temperature	32° F ~ 104° F (0° C - 40° C) Recommended 68° F - 86° F (20° C - 30° C)		
Relative Humidity	5% ~ 95% Non Condensing		
Altitude	0 ~ 9000 feet No Derating		
Location	Indoor (free from corrosive gases and dust) (PCB conformally coated for use in industrial environment)		
Paint Color	Munsell 5Y7/1 (Beige)		

TABLE 1.4 Rating of Contactors and Fuses

	NUMBER	APPLICATION	OUTPUT CAPACITY OF EQUIPMENT							
			2033D-B/C/D				2033D-A		2033D- B/C/D	
			30VA		50kVA		50kVA		80kVA	
			208V	480V	208V	480V	208V	480V	208V	480V
C O N T A C T O R	52RC	AC Input Contactor	60A				100A			
	52C	AC Output Contactor	60A				100A			
	52RS	Bypass Contactor	60A				100A			
	72B	Battery Disconnect Contactor	80A		135A		200A			
	88RC	Control circuit Contactor	90A							
F U S E	FIU, FIV, FIW	Inverter Output Fuse	80A/660V		140A/690V					
	FOU, FOV, FOW	Inverter Output Fuse	80A/660V		140A/690V					
	FUA, FUB, FUC	Control Power Fuse	30A/600V							
	FSU, FSV, FSW (Option)	Bypass Input Fuse	140A/690V		280A/660V					
	FBP, FBN	DC Input Fuse	125A/1250V		200A/1250V		350A/1250V			
	FZS1, 2, 3	Bypass Input ZNR Fuse	16A/500V							
	FBS1, 2	Control Power Fuse	10A/600V							
	FUF1, 2	Control Power Fuse	10A/600V							
	FZR1, 2, 3	AC Input ZNR Fuse	16A/500V							

2.0 OPERATOR CONTROLS AND INDICATORS

The 2033D Series operator controls and indicators are located as follows:

- Circuit breakers and contactors: Inside the module
- UPS status indicators: Outside of front door

FIGURE 2.1 Operation/Display Panel (Front panel)

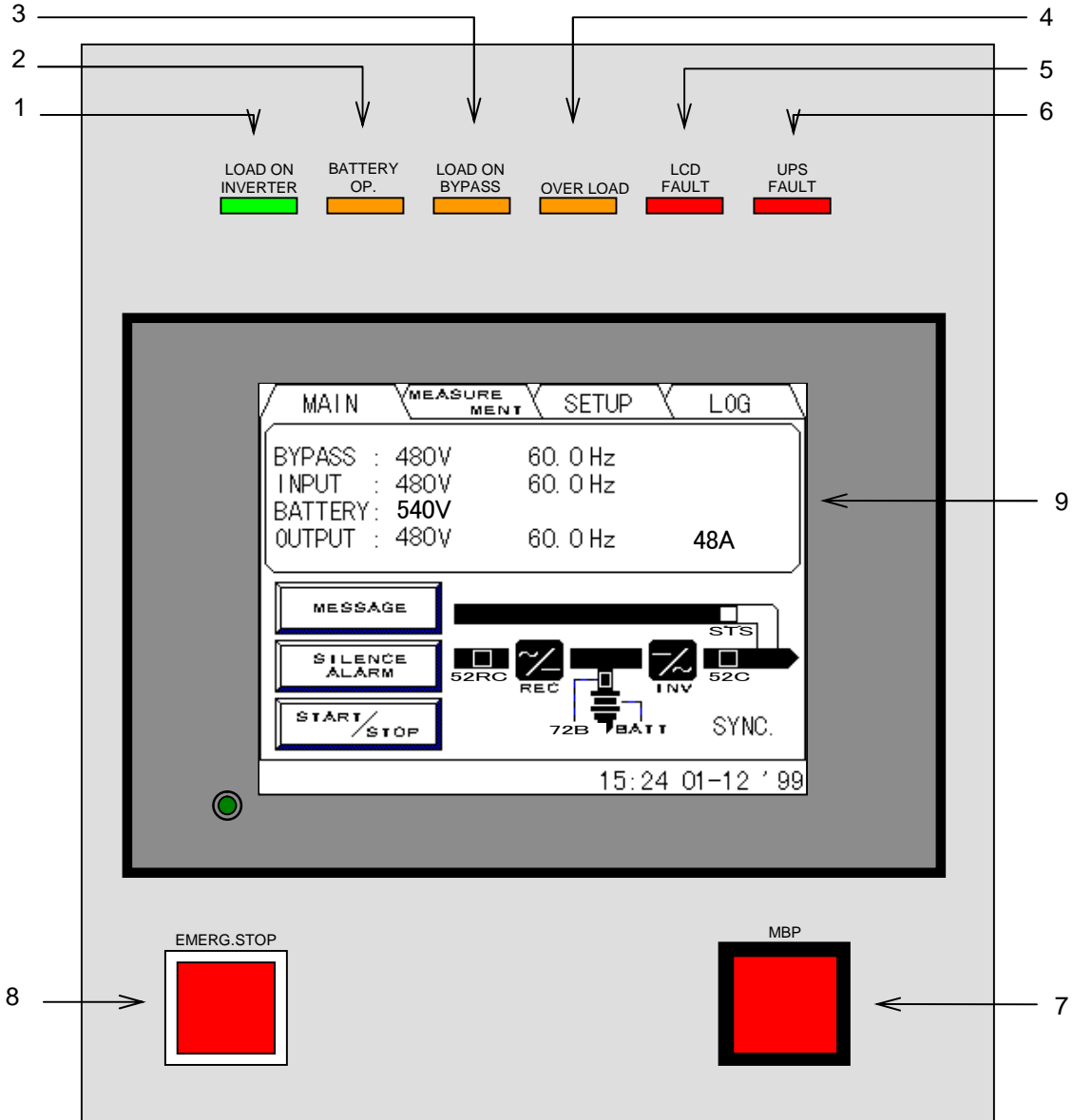

2.1 LED Display

1) Load on inverter [LOAD ON INVERTER](green)

Illuminates when power is supplied from inverter to the critical load.

(Indicates the state of inverter transfer switch "52C".)

2) Battery operation [BATTERY OP.](orange)

Illuminates when power is supplied from batteries following a power failure.

3) Load on bypass [LOAD ON BYPASS](orange)

Illuminates when power is supplied to load devices by static bypass.

4) Overload [OVERLOAD](orange)

Illuminates in overload condition.

5) LCD fault [LCD FAULT](red)

Illuminates when an error occurs.

6) UPS fault [UPS FAULT](red) [Annunciator: intermittent or constant tones]

Illuminates when an error occurs in the system. In this case, the details of the error are indicated on the display panel.

2.2 MBP Lamp (Maintenance Bypass Pilot Lamp) (7)

When operated in maintenance bypass mode, this lamp will be illuminated.

2.3 EPO button (Emergency Power Off button) (8)

When activated, the Emergency Power Off (EPO) function shuts down the UPS module.

The critical load will lose power and also shutdown. The EPO function can be performed both locally or remotely.

2.4 Liquid Crystal Display (9)

The Liquid Crystal Display (LCD) panel indicates power flow, measured values, operational guidance, data records and error messages. The LCD panel has a back-light which facilitates viewing in different ambient lighting conditions. The LCD will automatically clear and turn off, if the screen is not activated within 3 minute period. The LCD is turned back on when it is touched again. The ERROR indicator is cleared after 24 hours and can be reproduced by pressing any key on the panel.

2.4.1 Menus

A) MAIN MENU (FIGURE 2.2)

The LCD panel indicates power flow and measured values, while also operating the start/stop function. The LCD panel also allows the user to verify the status and operation of the UPS Module.

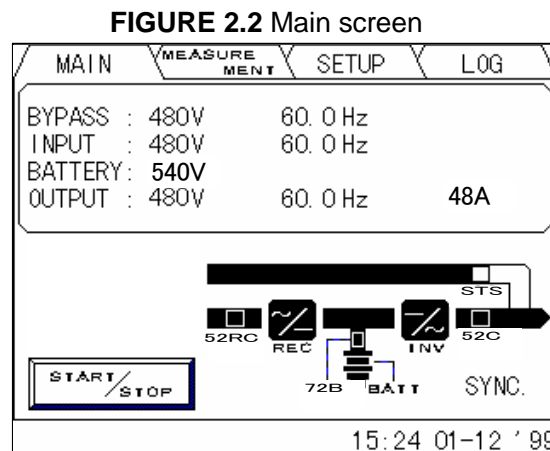

The following will be displayed when the START/STOP key on the LCD panel is pressed:

1.) Start/Stop screen (FIGURE 2.3)

The display indicates the start and stop operations for the UPS system. If this operation is PIN protected, the user is required to enter the security PIN before the screen can be accessed. Refer to (FIGURE 2.4).

When in remote mode, the message "REMOTE operating mode !" will appear on this Screen. The user cannot operate the start and stop functions without changing the setup from remote mode to local mode.

When bypass voltage is abnormal, the message "Bypass voltage abnormal" will appear.

-Start: When the bypass voltage is abnormal, the LCD asks the operator if an interrupted transfer is acceptable (Load may be lost). (FIGURE 2.5)

-Stop: When the bypass voltage is abnormal, the user cannot transfer from inverter to bypass line.

FIGURE 2.3 Start/Stop screen

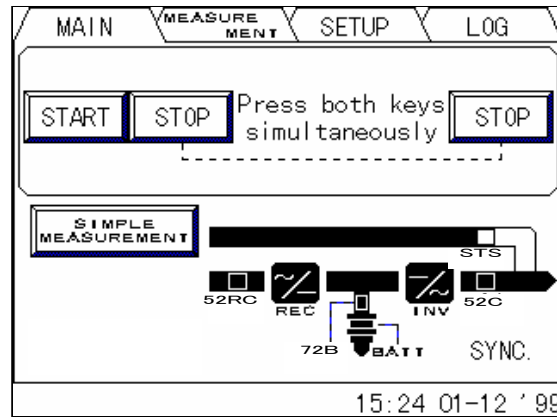

FIGURE 2.4 PIN protection screen

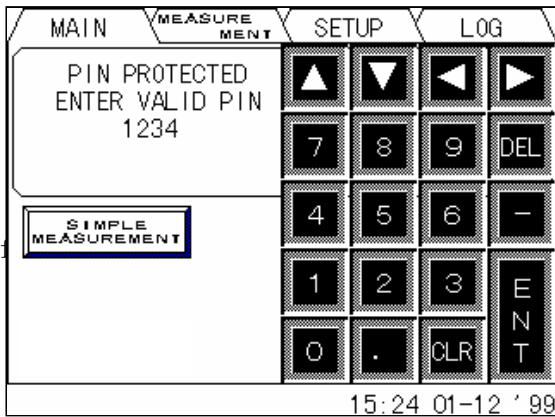
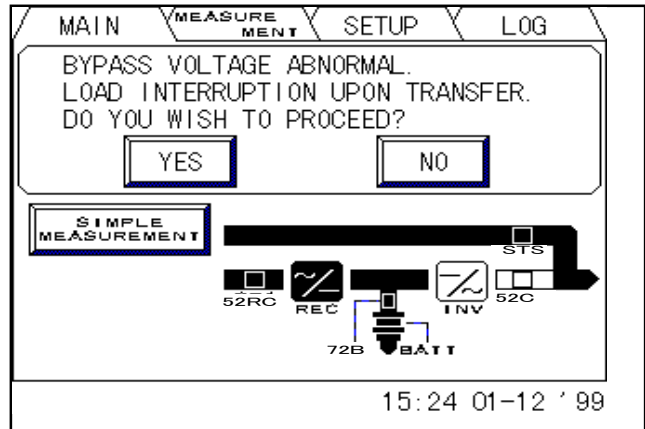

FIGURE 2.5 Bypass voltage abnormal message screen



B) MEASUREMENT MENU (FIGURE 2.6)

This screen shows details of measured values. Bypass voltage, input voltage, output line to line voltage and output frequency are displayed. Output currents are displayed as RMS values.

FIGURE 2.6 Measurement screen

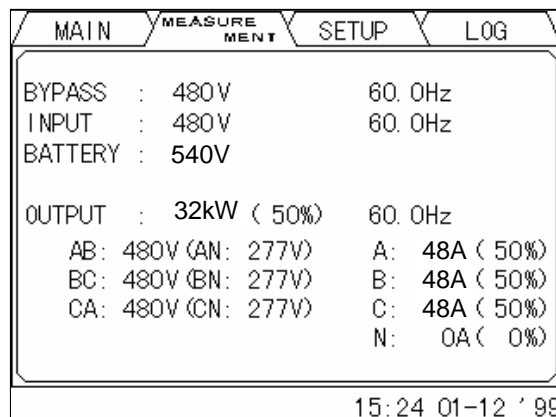

C) SETUP MENU (FIGURE 2.7)

This screen prompts the user to select: (a) whether the start & stop operation will be performed by local, remote or both operations; (b) date & time setup; (c) battery equalizing charge. The battery equalizing charge operation key will appear when battery equalizing charge is set up (Setup is based on battery type).

FIGURE 2.7 Setup screen

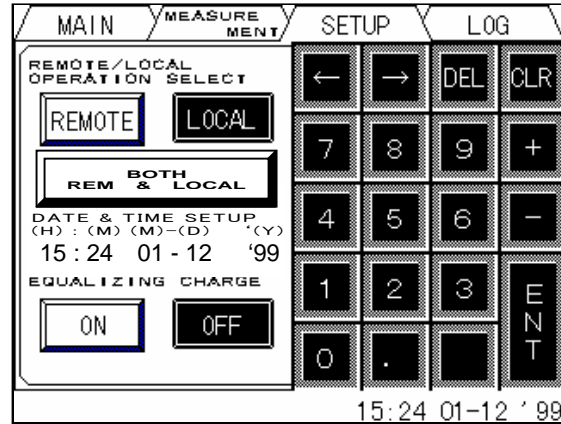

D) LOG MENU (FIGURE 2.8)

This menu shows operation / failure and battery discharge records.

FIGURE 2.8 Log select screen

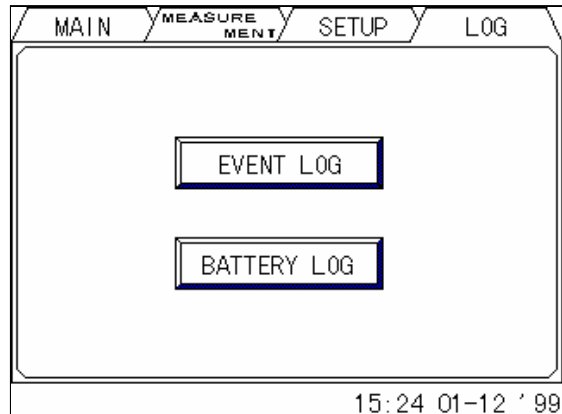

1.) Event log (FIGURE 2.9)

Operation and failure records are indicated. Maximum of 50 events are displayed.

FIGURE 2.9 Event log screen

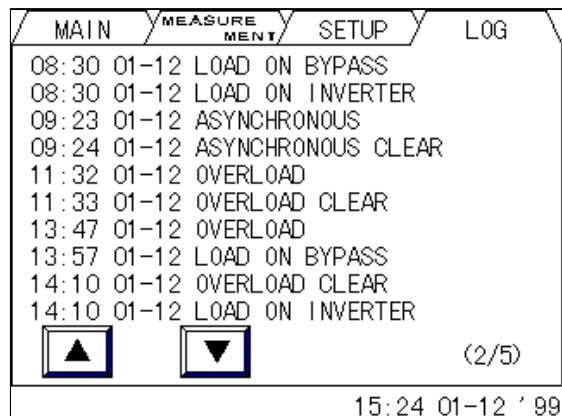

2.) Battery log (FIGURE 2.10)

This screen displays the cumulative battery discharging record.

FIGURE 2.10 Battery log screen

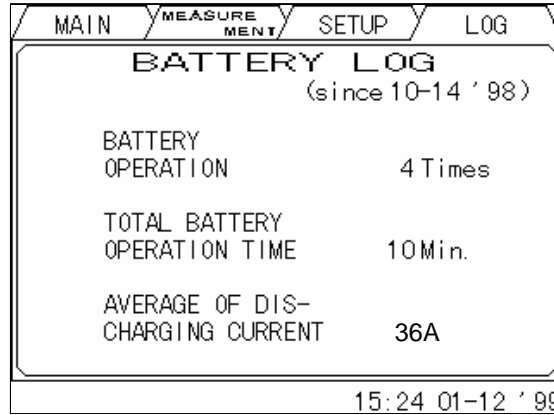

2.4.2 INPUT POWER FAILURE

During an Input Power Failure, the UPS inverter will be powered by the UPS batteries. The following will be displayed on the main and measurement screen (Indication of battery remaining capacity).

FIGURE 2.11 Main screen (Battery operation)

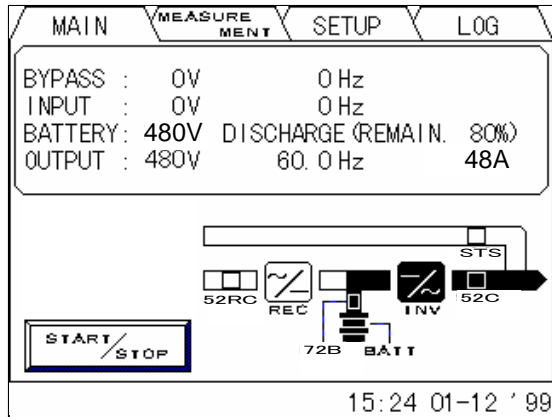
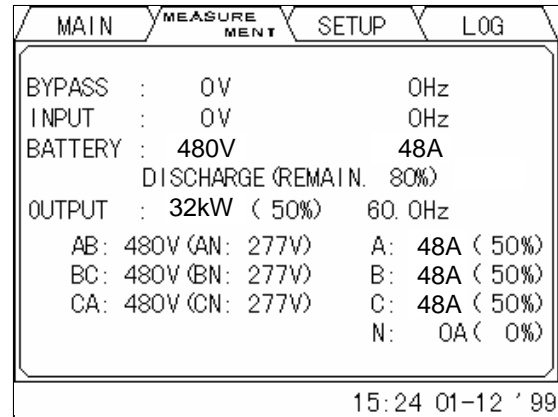

FIGURE 2.12 Measurement screen (Battery operation)



The LCD will display a battery low voltage message when the battery capacity is near depletion. The End of Battery Discharge announcement is displayed when the battery end voltage is reached. At this time, the inverter will perform an electronic shutdown to prevent battery loss of life typical from extreme deep discharge conditions. When the input power is restored, the inverter will automatically restart to power the load, and the batteries will be simultaneously recharged. The End of Battery announcement is shown at the bottom of the screen.

2.4.3 FAULT INDICATION (FIGURE 2.13)

“MESSAGE” and “SILENCE ALARM” buttons will appear on the main menu when UPS failure condition has occurred.

FIGURE 2.13 Main screen (Fault indication)

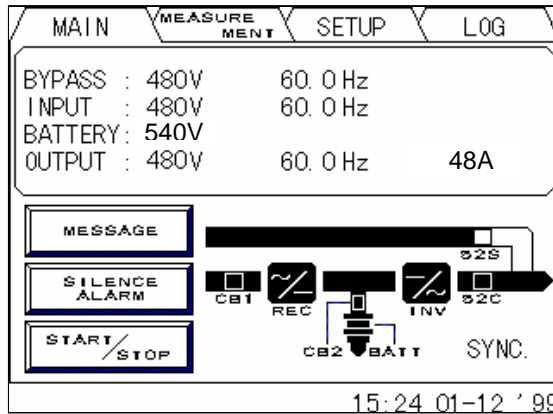

The following will be displayed when the message key on the LCD panel is pressed.

1) Message (FIGURE 2.14)

The display shows a fault code, the description of the fault and a guidance of what action is to be taken by the user. A maximum of 10 faults is displayed at one time. If an input power failure occurs during a fault condition, the fault indication and input power failure announcement are alternatively displayed at 5 second intervals.

FIGURE 2.14 Message screen

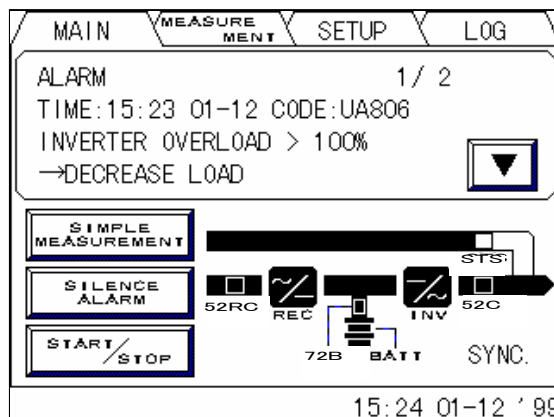

2) Silence alarm

This key will appear when a failure occurs. The audible alarm (announcing the failure) can be silenced by pressing this key.

2.5 External Signal Terminal Block

The UPS is equipped with a series of input/output terminals for external annunciation of alarms and for remote access of certain UPS functions. The layout of terminals is shown in Figure 2.15-1, -2 with a functional description of the input/output port presented. OUT1 to OUT9 are user programmable, but factory default setting are shown in Figure 2.15.

FIGURE 2.15-1 External Signal Terminal Block (NEC Class2)

TN1

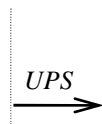
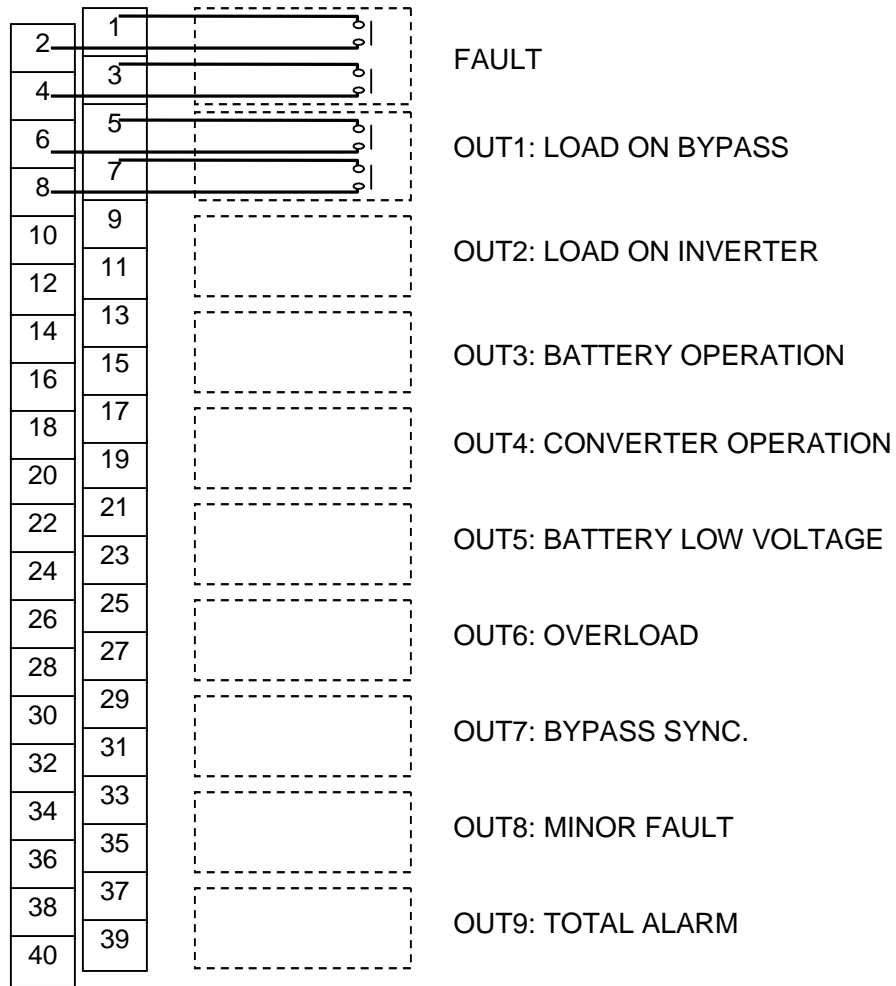
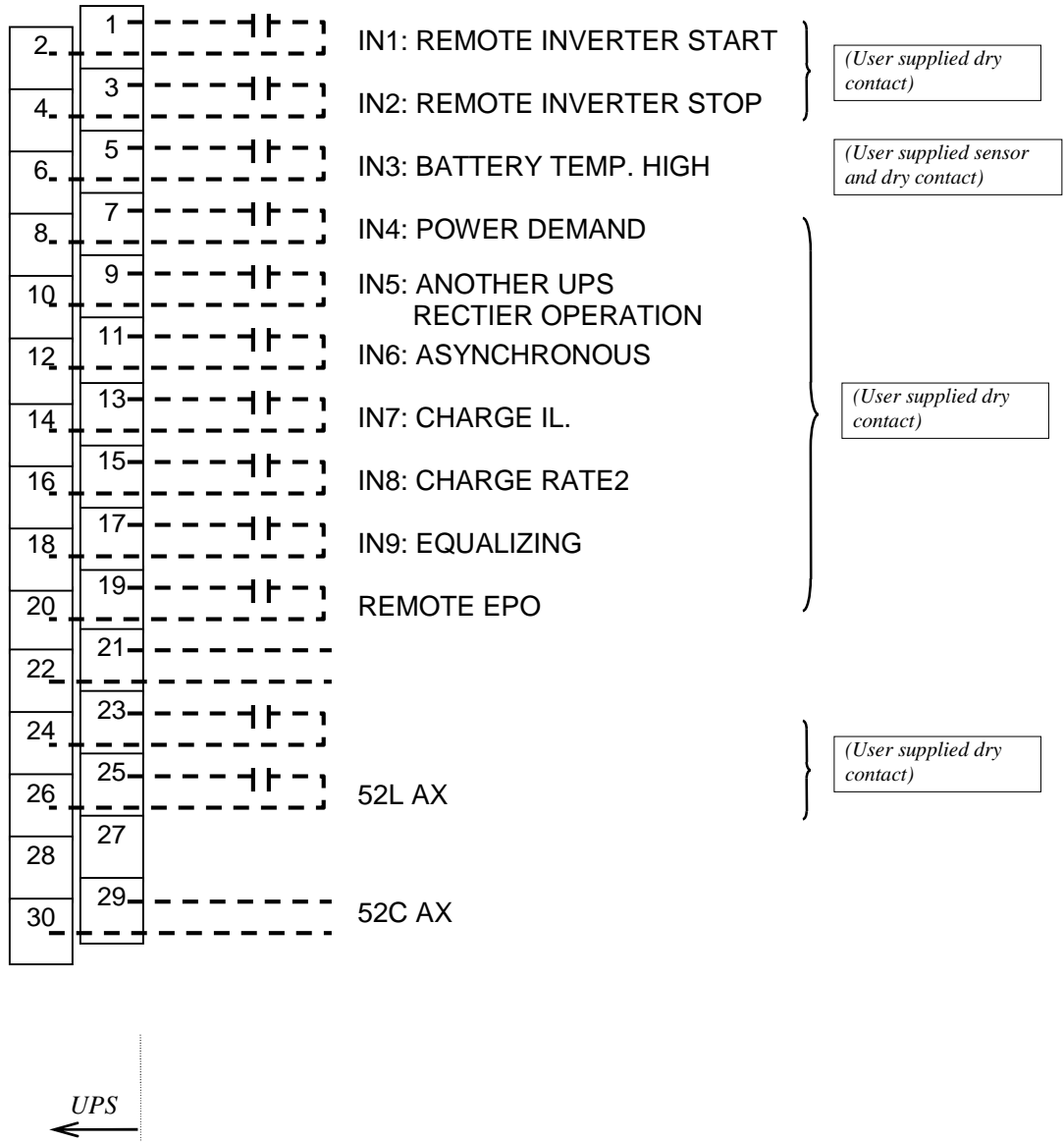

FIGURE 2.15-2 External Signal Terminal Block (NEC Class2)

TN2



A) Output Contacts (for external alarm annunciation)

Output contacts consist of form “A” dry type contacts. Rated capacity of all output contacts is NEC Class2 (30Vdc/1Adc). All dry contacts should be operated at their rated values or lower. Figure 2.16 illustrates a typical installation. The external relay can also be a lamp, LED, computer, etc.

FIGURE 2.16 Control Wiring for External Contacts

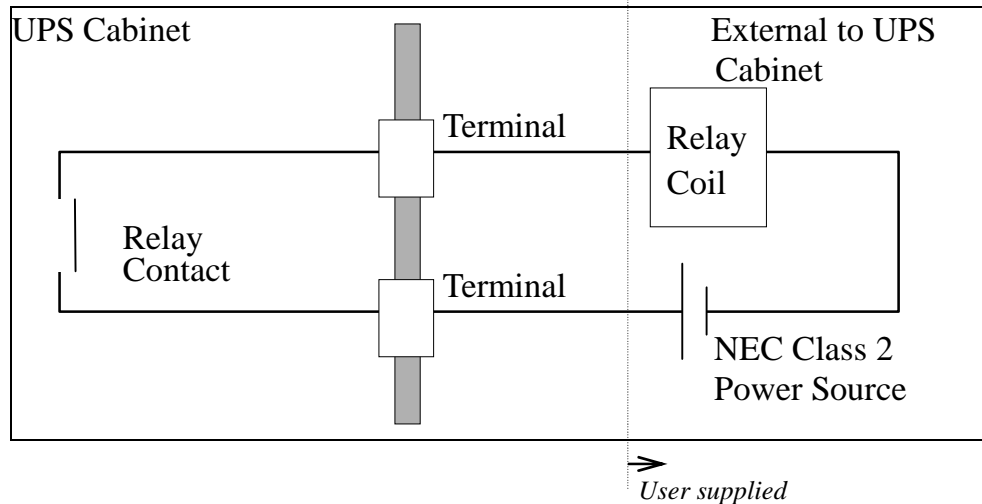

Details of output alarm contacts : TN1

Terminals 1 to 2, 3 to 4 "UPS failure" contact

Activated when a major fault has occurred to the system.

Terminals 5 to 6, 7 to 8 "Load on Bypass" contact (OUT1)

Activated when the power is supplied from the static bypass input.

Terminals 9 to 10, 11 to 12 "Load on Inverter" contact (OUT2)

Activated when the power is supplied by the inverter.

Terminals 13 to 14, 15 to 16 "Battery Operation" contact (OUT3)

Activated when the battery is operating following an AC power failure.

Terminals 17 to 18, 19 to 20 "Converter Operation" contact (OUT4)

Activated when the converter is operating.

Terminals 21 to 22, 23 to 24 "Battery Low Voltage" contact (OUT5)

Activated when the battery voltage drops below discharge end voltage level during inverter operation (i.e. During AC fail condition).

Terminals 25 to 26, 27 to 28 "Overload" contact (OUT6)

Activated when an overload has occurred to the system.

Terminals 29 to 30, 31 to 32 "Bypass Sync." contact (OUT7)

Activated when the system is in sync. Mode.

Terminals 33 to 34, 35 to 36 "**Minor Fault**" contact (OUT8)

Activated when a minor fault has occurred to the system.

Terminals 37 to 38, 39 to 40 "**Total Alarm**" contact (OUT9)

Activated when an alarm, a minor fault, or a major fault has occurred to the system.



NOTE: *The UPS is equipped with a selectable output contact feature. The above alarms are the default settings. Contact **MITSUBISHI ELECTRIC POWER PRODUCTS, INC.** for setup information.*

B) Input Contacts (for remote access of UPS)

External contacts are provided by the user of the UPS system. Terminal voltage at the UPS is 24Vdc. Provide external dry contact accordingly.



NOTE: *Do not apply voltages to remote access input terminals. Damage to UPS may result.*

Refer to Figure 2.17 for a typical wiring configuration. Although this figure applies to the remote start/stop terminals, the same wiring arrangement is used for emergency stop; battery liquid low; and battery temperature high.

FIGURE 2.17 Remote "Start" Contact Connections

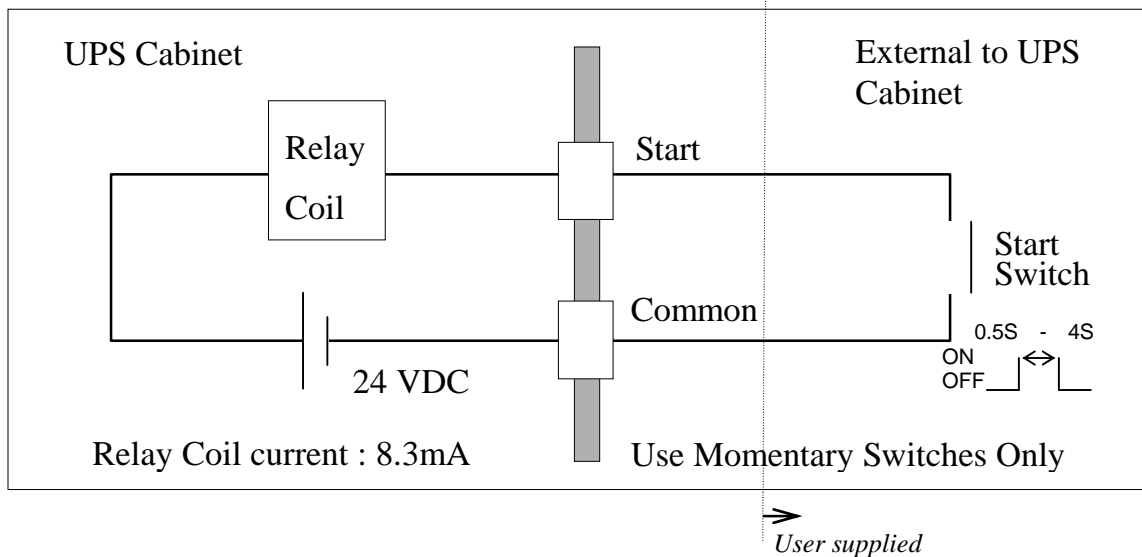

Details of input contacts for remote access : TN2

Terminals 1 to 2 **Remote "Inverter Start" input terminal (IN1)**

Used to start inverter from a remote location. UPS must be programmed for remote operation. Refer to Operations Menu for procedure.

Terminals 3 to 4 **Remote "Inverter Stop" input terminal (IN2)**

Used to stop inverter from a remote location. UPS must be programmed for remote operation. Refer to Operations Menu for procedure.

Terminals 5 to 6 "Battery Temp. High" contact input (IN3)

Input fed by a thermostat that monitors battery temperature. The converter float voltage level is reduced for battery over-temperature conditions. External thermocouple is user supplied

Terminals 7 to 8 "Power Demand Command" contact input (IN4)

This contact is used to control the input power. Power demand is turned ON when the contact is closed, and power demand is turned OFF when the contact is open.

Terminals 9 to 10 "Another UPS Converter Operation" contact input (IN5)

Used for MMS mode, this contact is used to see if other UPS' are in converter operation or not. When the contact is closed, then at least one of the other UPS' converter is operating. When the contact is open, then all the other UPS' converters are not operating.

Terminals 11 to 12 "Asynchronous" contact input (IN6)

This contact is used to control sync. mode. The system is in asynchronous mode when the contact is closed, and is in synchronous mode when the contact is open.

Terminals 13 to 14 "Charger IL." contact input (IN7)

This contact is used to control charging of the batteries. When the contact is closed, UPS will stop charging batteries. When the contact is open, UPS will start charging the batteries.

Terminals 15 to 16 "Charge Rate 2" contact input (IN8)

This contact is used to change the battery charge rate setting. Charge rate 2 is used when the contact is closed, and charge rate 1 is used when the contact is open.

Terminals 17 to 18 "Equalizing" contact input (IN9)

This contact is used to control equalizing of the batteries. Equalizing is turned ON when the contact is closed, and is turned OFF when the contact is open.

Terminals 19 to 20 "Remote EPO" contact input

Used to perform a remote UPS Emergency Power Off (EPO).
The load will be dropped.



NOTE: *The UPS is equipped with a selectable output contact item. The above items are the default settings. Contact MITSUBISHI ELECTRIC POWER PRODUCTS, INC. for setup information.*



NOTE : *In all cases, a switch having a protective cover is recommended in order to reduce the possibility of accidental operation.*

2.6 External communication connector

This is an RS232C port for “DiamondLink”^{*} monitoring software.

The layout of connector is shown in Figure 2.18.

FIGURE 2.18 External communication connector (NEC Class2)

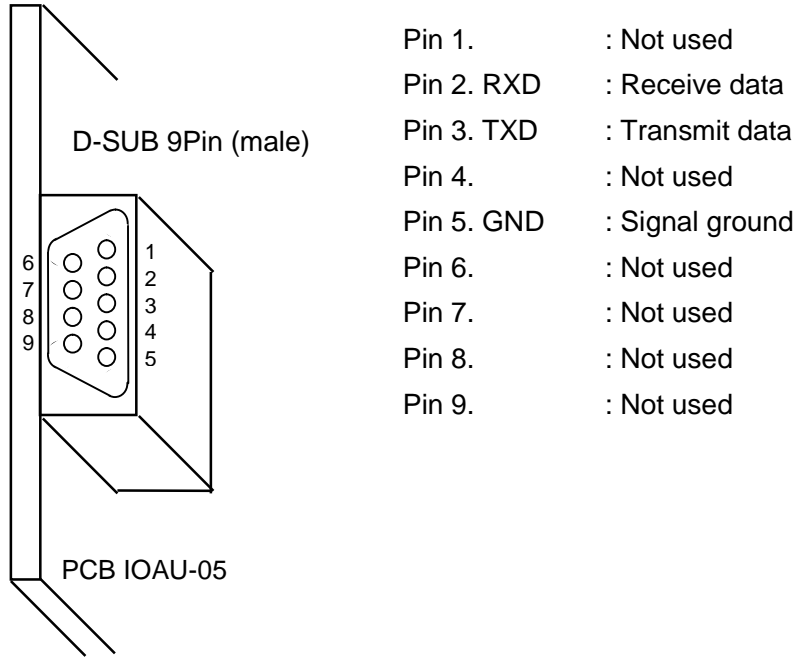

** Consult MITSUBISHI ELECTRIC POWER PRODUCTS, INC. for details on “DiamondLink” monitoring software and its capabilities.*

3.0 INSTALLATION AND OPERATION

3.1 Transportation and Installation

TABLE 3.1 How to transport and install the system

Transportation	Installation
Transport unit with forklift. Carry with overhead crane using eyebolts provided.	Using the pre drilled holes (4 - 24) in the UPS channel base, anchor the unit using appropriate hardware. (Not provided)



Note : *Do not transport in a horizontal position. Cabinets must be maintained upright within +/- 15° of the vertical during handling.*

3.2 Installation Procedure

A) Note the load tolerance of the floor

Refer to Table 3.2 for list of UPS weights.

TABLE 3.2 List of UPS weights

UPS Capacity (kVA)	30	50	80
Weight (lb)	2060	1580	1990

B) Minimum clearance required for ventilation

Right side 1.0" (25 mm) (not required when sidecars are used)

Left side 1.0" (25 mm) (not required when sidecars are used)

Back side 0.0" (0.0 mm)

Top side 23.6" (600 mm) (for air flow)

C) Space requirement for routine maintenance

Allow for the following space at the time of installation.

Front 39.4" (1000 mm)

Sides 0.0" (0.0 mm)

Rear 0.0" (0.0 mm)

D) Battery

Please refer to the following when installing and maintaining batteries:



1. Servicing of batteries should be performed or supervised by personnel knowledgeable of batteries and the required precautions. Keep unauthorized personnel away from batteries.
2. When installing or replacing batteries, install or replace with the same number and type per Table 3.3

TABLE 3.3 Type and number of battery

	Type	Manufacturer	Number
30kVA	NP18-12BFR	Yuasa Corp.	40
	NPX-80FR	Yuasa Corp.	40
	XE16	EnerSys	40
	SR12-80F	BPI	40
	SR12-95F	BPI	40
50kVA, 80kVA			

Note: 50kVA and 80kVA UPS batteries are external to module cabinet.
Please refer to the remote battery supply installation manual.



3. CAUTION - Do not dispose of battery or batteries in a fire. The battery may explode.
4. CAUTION - Do not open or mutilate the battery or batteries. Released electrolyte is harmful to the skin and eyes and may be toxic.
5. CAUTION - A battery can present a risk of electrical shock and high short circuit current. The following precautions should be observed when working on batteries:
 - (1) Remove watches, rings, or other metal objects.
 - (2) Use tools with insulated handles.
 - (3) Wear rubber gloves and boots.
 - (4) Do not lay tools or metal parts on top of batteries.
 - (5) Disconnect charging source prior to connecting or disconnecting battery terminals.

E) External Battery Supply

Please refer to the following when installing and maintaining batteries:



1. The customer shall refer to the battery manufacturer's installation manual for battery installation and maintenance instructions.
2. The maximum permitted fault current from the remote battery supply, and the DC voltage rating of the battery supply over-current protective device are shown in Table 3.4.

TABLE 3.4 Maximum Permitted Fault Current

UPS CAPACITY (kVA)	DC VOLTAGE RATING (V)	MAXIMUM PERMITTED FAULT CURRENT (A)
30	480	25000
50	480	25000
80	480	25000

3.3 Procedure for Cable Connections *

- i. Confirm the capacity of the UPS being installed. Identify the input/output power terminal blocks as shown in the appropriate Figures 3.1-a, b through 3.2-a, b.
- ii. Connect the grounding conductor from the input service entrance to the UPS ground bar.
**Wire per local and/or national code.*
- iii. Two (2) sources feeding the UPS:
 - (1) Connect the converter input power cables from the input service entrance to the converter input power terminals, identified as A, B, C in Figures 3.2-a, b. Input cables must be sized for an ampere rating larger than the maximum input drawn by the converter. (Refer to equipment nameplate for current ratings.) Refer to Table 3.5 for recommended cable sizes.
 - (2) Confirm that an external bypass input circuit breaker (MCCB) is installed (refer to WARNING 2, page 1-2). Connect the bypass input power cables from the input service entrance to the bypass input power terminals, identified as A40, B40, and C40 in Figures 3.2-a, b. Bypass input cables must be sized for an ampere rating larger than the maximum output current capacity of the UPS. Refer to Table 3.5 for recommended cable sizes.
 - (3) Referring to Figures 3.2-a, b, connect UPS load terminals A50, B50, C50 and N50 to the load distribution panel. Refer to Table 3.5 for cable sizes.
 - (4) Connect the external signal terminal block as desired. Refer to section 2.5 and Figure 2.15 for functional description. 12 AWG, or less, shielded conductor is recommended.

iv. One (1) source feeding the UPS:

- (1) Confirm that an external input circuit breaker sized to protect both the converter input and the bypass line is installed. (Refer to equipment nameplate for current ratings.) Connect the bypass input power cables from the input service entrance to the bypass input power terminals, identified as A40, B40, and C40 in Figures 3.2-a, b. Input cables must be sized for an ampere rating larger than the maximum current capacity of the UPS. Refer to Table 3.5 for recommended cable sizes.
- (2) Using adequately sized conductors per Table 3.5 and referring to the appropriate figure identified in Figures 3.2-a, b, connect jumper bypass terminals A40, B40, C40 to converter input power terminals A, B, C as identified in Figures 3.2-a, b.
- (3) Referring to Figures 3.2-a, b, connect UPS load terminals A50, B50, C50 and N50 to the load distribution panel. Refer to Table 3.5 for cable sizes.
- (4) Connect the external signal terminal block as desired. Refer to section 2.5 and Figure 2.15 for functional description. 12 AWG, or less, shielded conductor is recommended.

NOTES: 1. *Confirm that all UPS internal contactors (breakers) "52RC "72B", "52RS", and "52C" are open before energizing UPS.*



2. *UPS power terminals are supplied with stud type fittings. It is recommended that compression lugs be used to fasten all input/output power cables. Refer to Table 3.6 for recommended compression lugs and appropriate crimping tool.*

v. **Procedure for Parallel System Cable Connections**

- (1) Identify the input/output power terminal blocks and control wire connections for parallel systems as shown in the appropriate Figure 3.4.
- (2) Connect the external control wire and power wire.
 - a.) Control wire connection
 - Parallel configuration Wiring (Refer to Figure 3.4)
 - Critical Load Cabinet (CLC) TB1 to UPSn IOAU-05, TN2.
 - Parallel Control In, Out cables between UPS modules
 - b.) Power wire connection
 - From UPS AC Output Terminals to CLC (Refer to Figure 3.4)

TABLE 3.5 Recommended cable size and torque requirements

kVA Capacity	Input Voltage	Output Voltage	Input Side * 1, 2		Output Side * 1, 2		Bypass Side * 1, 2		DC Input Side * 1, 2	
			Cable Size	Torque in. lbs	Cable Size	Torque in. lbs	Cable Size	Torque in. lbs	Cable Size	Torque in. lbs
30kVA	480V	480V	6 AWG or larger	42-56 in. lbs	6 AWG or larger	100-135 in. lbs	6 AWG or larger	42-56 in. lbs	4 AWG or larger	100-135 in. lbs
	480V	208V	6 AWG or larger	42-56 in. lbs	1 AWG or larger	100-135 in. lbs	6 AWG or larger	42-56 in. lbs	4 AWG or larger	100-135 in. lbs
50kVA	480V	480V	3 AWG or larger	100-135 in. lbs	4 AWG or larger	100-135 in. lbs	3 AWG or larger	100-135 in. lbs	1 AWG or larger	100-135 in. lbs
	480V	208V	3 AWG or larger	100-135 in. lbs	3/0 AWG or larger	100-135 in. lbs	3 AWG or larger	100-135 in. lbs	1 AWG or larger	100-135 in. lbs
80kVA	480V	480V	1/0 AWG or larger	200-269 in. lbs	1/0 AWG or larger	100-135 in. lbs	1/0 AWG or larger	200-269 in. lbs	4/0 AWG or larger	200-269 in. lbs
	480V	208V	1/0 AWG or larger	200-269 in. lbs	2x2/0 AWG or larger	100-135 in. lbs	1/0 AWG or larger	200-269 in. lbs	4/0 AWG or larger	200-269 in. lbs

*1 – The cables must be selected to be equal to or larger than the sizes listed in the table.

*2 - Voltage drop across power cables not to exceed 2% of nominal source voltage.

*3 - Allowable ampere rating based on 75 deg C insulation at ambient temperature of 40 deg C.

No more than 3 conductors in a raceway without de-rating.

Note : Copper conductors are assumed.

TABLE 3.6 Crimp Type Compression Lug

WIRE SIZE (CODE)	WIRE STRAND CLASS	RECOMMENDATION		CRIMP TOOL REQUIRED BURNDY TYPE Y35 OR Y46	
		VENDOR	CAT. NO.	COLOR KEY	DIE INDEX
6	B	BURNDY	YA6C	BLUE	7 / 374
	B/I	ILSCO	CRB-6L	BLUE	7 / 374
	I	BURNDY	YA5C-LB	-----	1014
4	B	BURNDY	YA4C	GRAY	8 / 346
	B/I	ILSCO	CRB-4L	GRAY	8 / 346
	I	BURNDY	YA3C-LB	-----	1016
3	B	BURNDY	YA3C	WHITE	9
	B	ILSCO	CRA-3L	WHITE	9
	I	BURNDY	YA2C-LB	-----	1017
1	B	BURNDY	YA1C	GREEN	11 / 375
	B	ILSCO	CRA-1L	GREEN	11 / 375
	I	BURNDY	YA25-LB	-----	1019
1/0	B	BURNDY	YA25	PINK	12 / 348
	B	ILSCO	CRA-1/OL	PINK	12 / 348
	I	BURNDY	YA26-LB	-----	1020
2/0	B	BURNDY	YA26	BLACK	13
	B	ILSCO	CRA-2/OL	BLACK	13
	I	BURNDY	YA27-LB	-----	1021
3/0	B	BURNDY	YA27	ORANGE	14 / 101
	B	ILSCO	CRB-3/OL	ORANGE	14 / 101
	I	BURNDY	YA28-LB	-----	1022
4/0	B	BURNDY	YA28	PURPLE	15
	B	ILSCO	CRB-4/OL	PURPLE	15
	I	BURNDY	YA29-LB	-----	1023

NOTE: *When using crimp type lugs, the lugs should be crimped to the specifications given in the manufacturer's instructions for both crimp tool and lug.*

FIGURE 3.1-a UPS Terminal Designation (30kVA UPS)

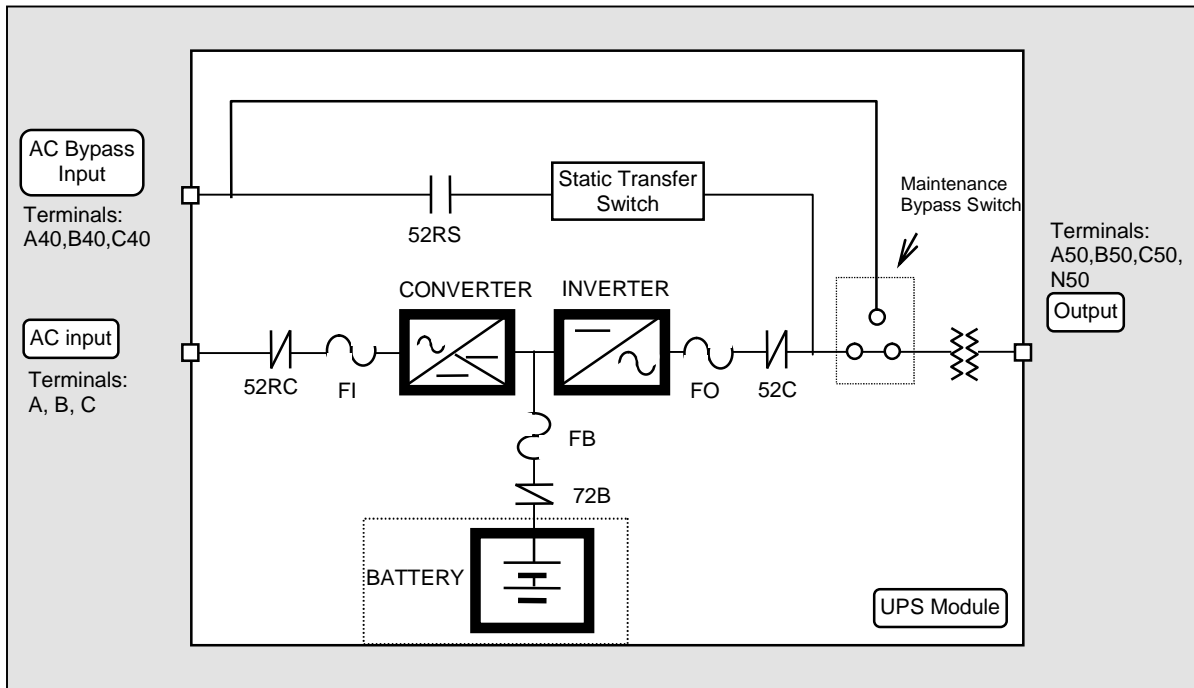

FIGURE 3.1-b UPS Terminal Designation (50kVA, 80kVA UPS)

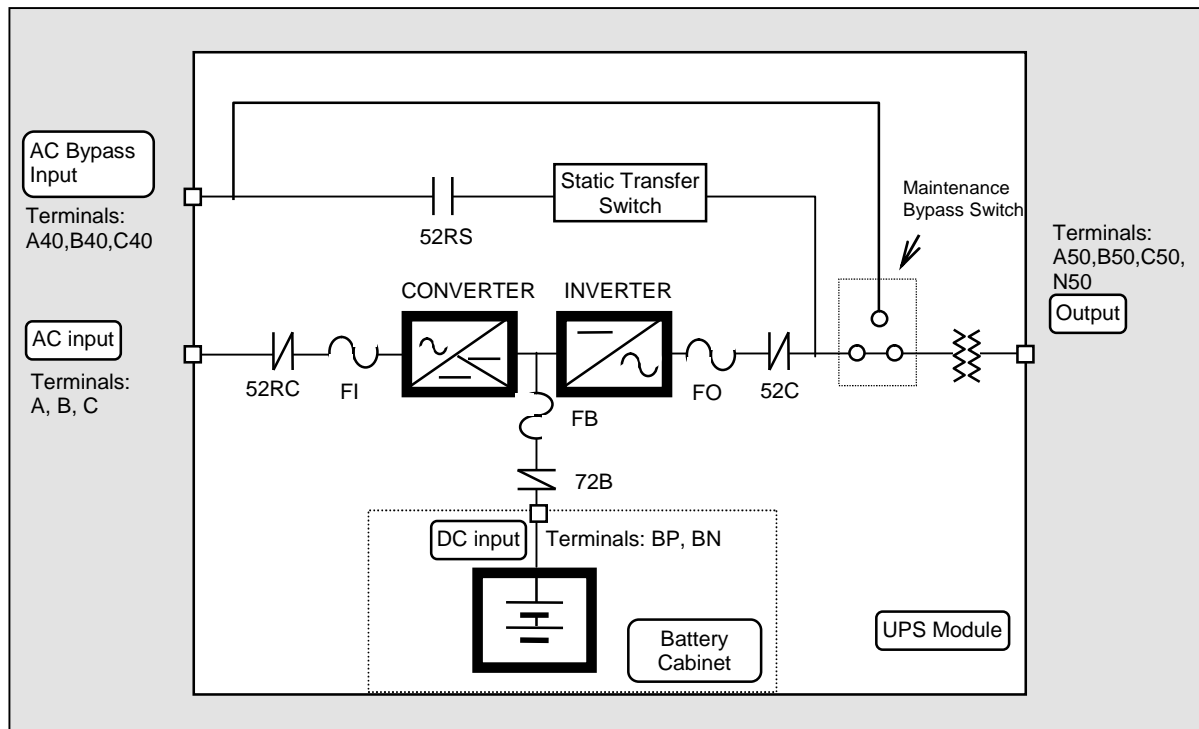

FIGURE 3.2-a Diagram of input/output bus bars and terminal blocks (30kVA UPS)

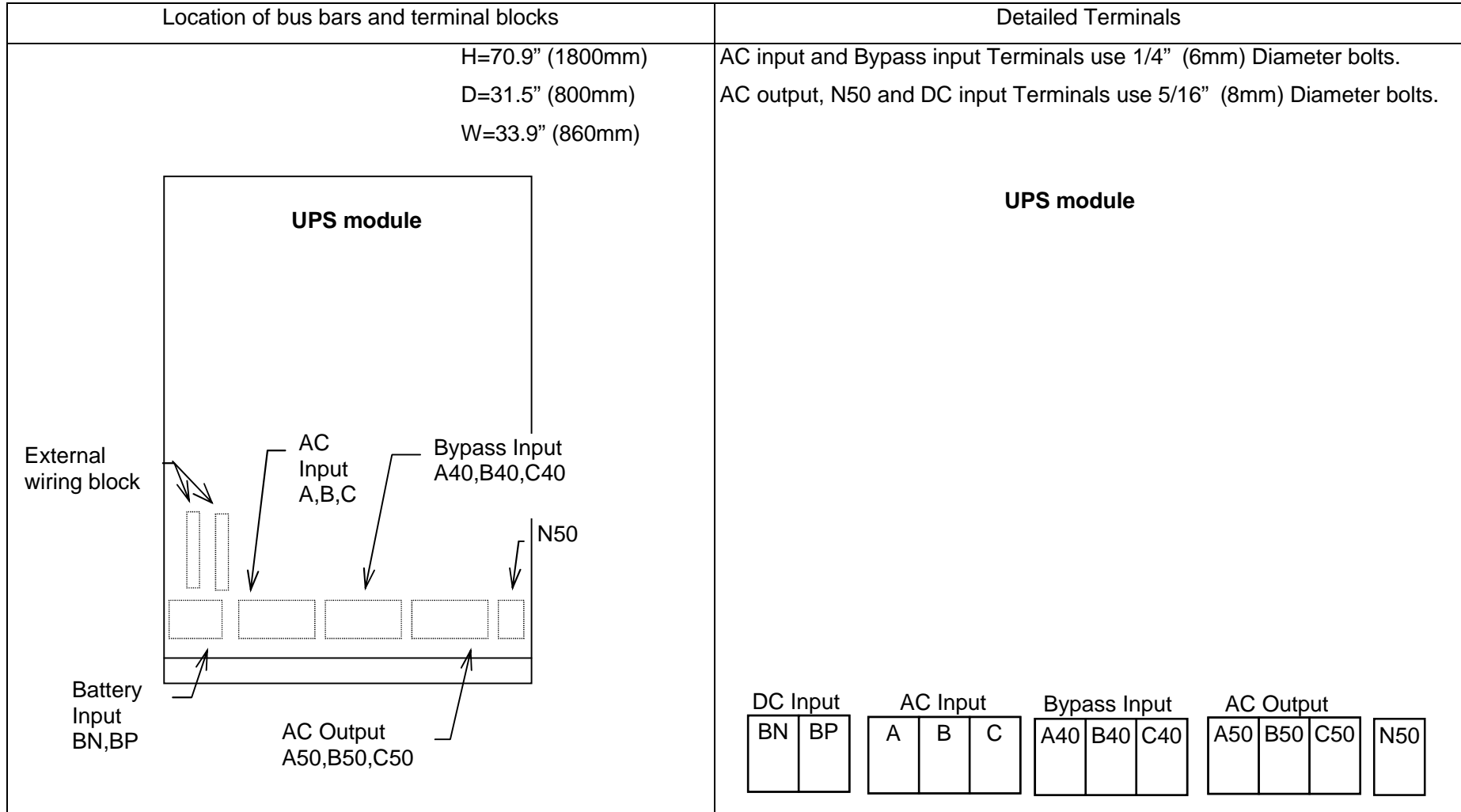

FIGURE 3.2-b Diagram of input/output bus bars and terminal blocks (50kVA, 80kVA UPS)

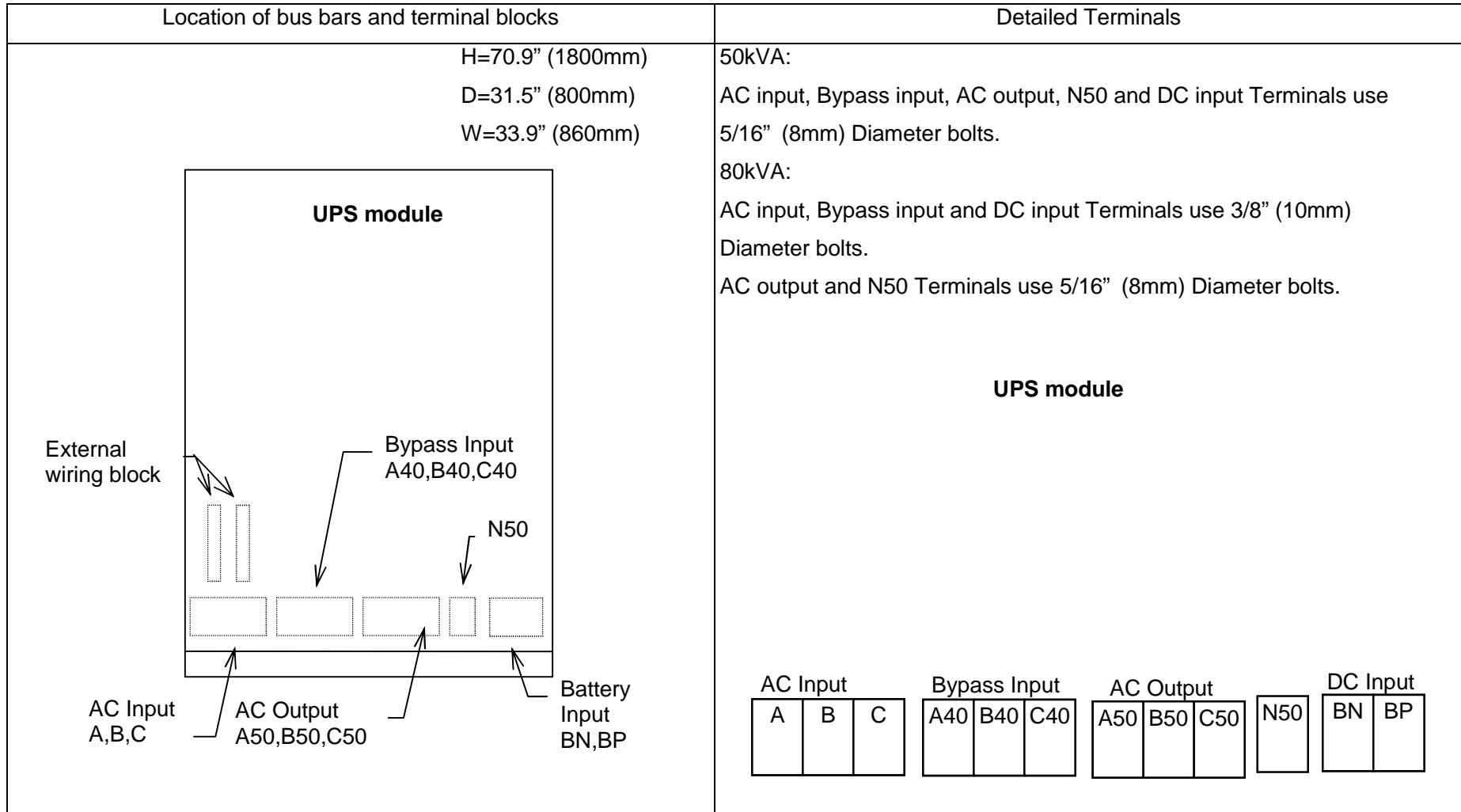



FIGURE 3.3 Diagram of Power Wire Connect (Parallel Connection)

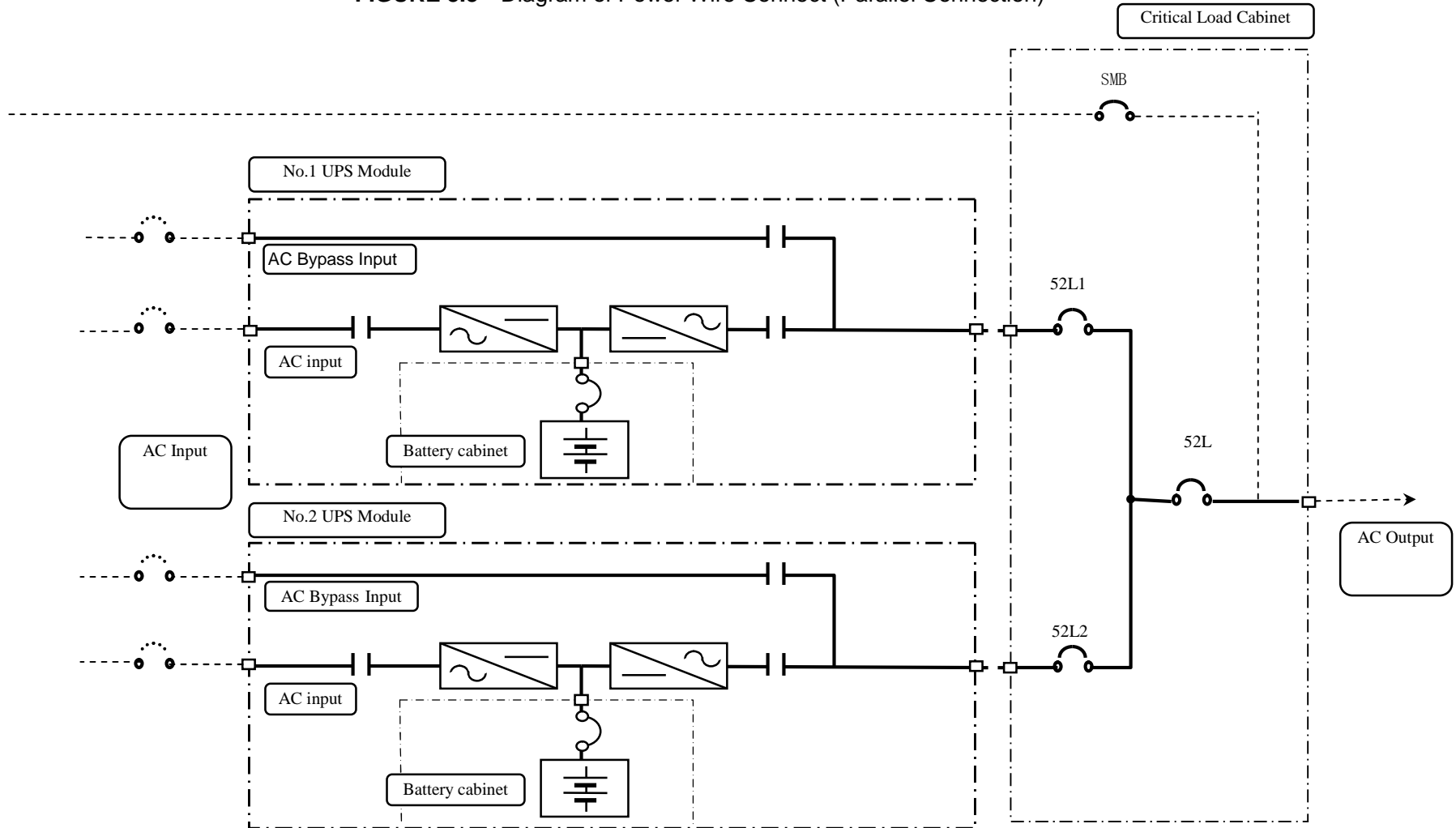
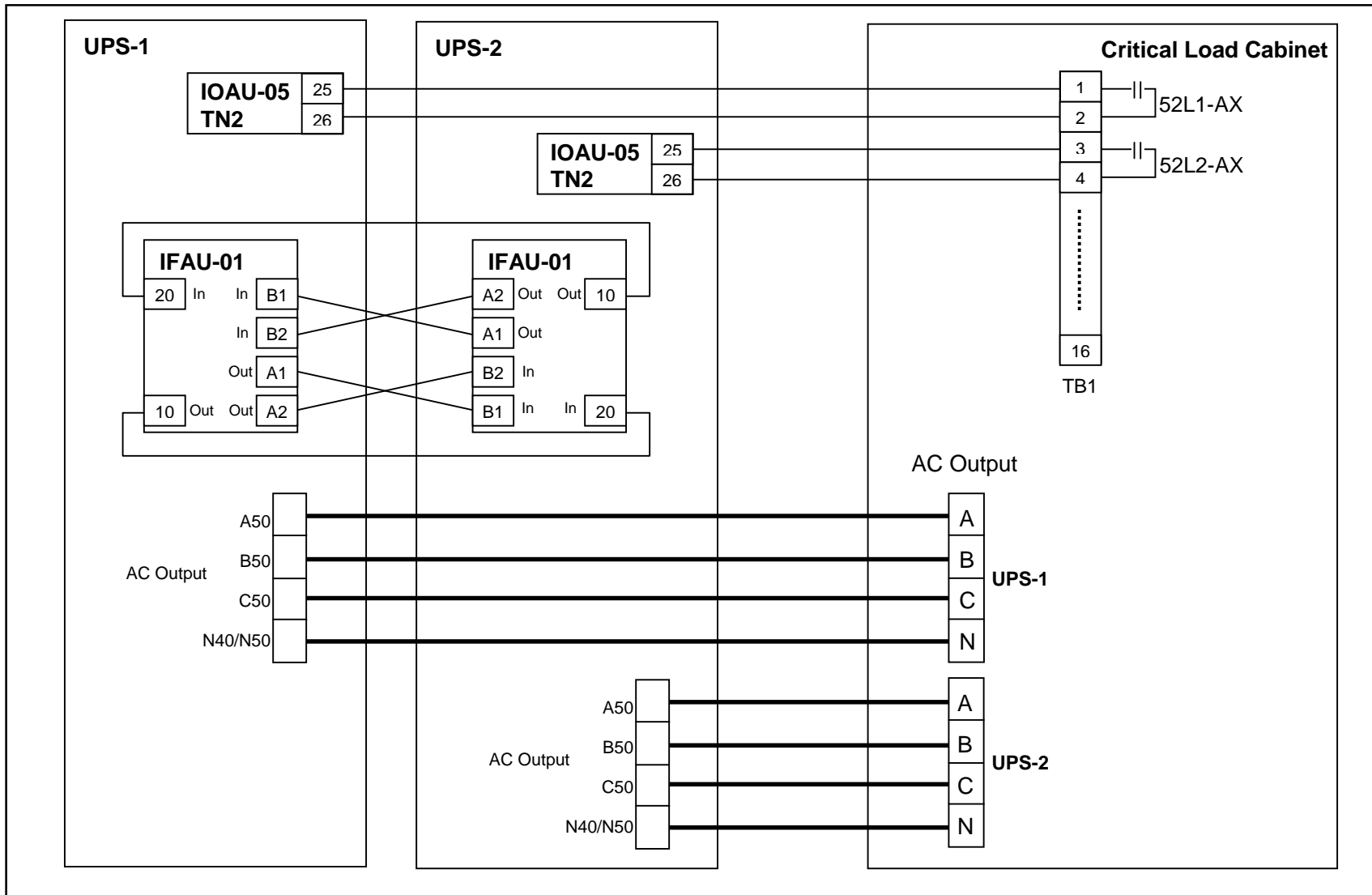



FIGURE 3.4 Diagram of Power Wire & Control Wire Connect (Parallel connection)



3.4 Operating Procedures for Single Module System

This section shows the operating procedures for a UPS Single Module System (SMS).

For Multi Module System (MMS), refer to section 3.6 Operating Procedures for Multi Module System.

A) UPS Start-up Procedure

1. Confirm MBS(52CS)(Figure 1.4) is in "NORMAL" position.
2. Close External AC and Bypass Input Circuit Breaker (User supplied).
3. The "LOAD ON BYPASS." LED turns on and power is supplied to the critical load from the static bypass line automatically.
4. Within ten (10) seconds, the "LOAD ON INVERTER" LED flashes and the Inverter starts. The UPS will automatically transfer the load from the static bypass line to the inverter and the "LOAD ON INVERTER" light turns on.

B) UPS Shutdown Procedure

If a total UPS shutdown is required, verify that the critical load is OFF.

Shut-down of UPS

1. Press the "START/STOP MENU" from the Main Menu on the LCD.



Note: When "REMOTE OPERATION MODE" is displayed on the LCD panel, the inverter stop operation can only be performed remotely. If local inverter stop operation is required (at the UPS), select "LOCAL" in "Remote/Local" selection in setup page. Select "LOCAL" mode for the purpose of this stop procedure.

2. Press both "STOP" keys simultaneously on the LCD.



WARNING : Verify the load is OFF if the next step is to be performed.



Note: Power to the critical load is supplied through the static bypass line. Power to the critical load will be lost after execution of the next step. The load will be dropped.

3. If turning off all power to the critical load is desired, open the AC and Bypass Input Circuit Breaker (User supplied.).



WARNING : *In bypass mode, all UPS power terminals are still live. Lethal voltages are present. De-energize all external sources of AC and DC power before handling UPS.*

C) Emergency Power Off(EPO) Procedure

If all power supply shutdown is required in an emergency, press the "EMERG. STOP" button on the front panel. The UPS will be shutdown and the load will not be supplied.



WARNING : *When operating remote EPO, it is necessary to open the input circuit breaker, which is user supplied.*

3.5 Internal Maintenance Bypass set-up procedures for Single Module System

A) Transfer of load from inverter to maintenance bypass

1. Stop the inverter by pressing the START/STOP key on the LCD's Main Menu (see Figure 2.3). Simultaneously press the two (2) STOP keys per the instructions. (Note : inverter STOP function inhibited if bypass and inverter are out of sync.)
2. Confirm via the flow diagram on the LCD that the load is fed from the UPS' static bypass line. Also confirm that the "LOAD ON BYPASS" LED is on (No.3 LED on Figure 2.1)
3. Rotate MBS (52CS) clockwise to the "TRANSFER" position (see figure 1.4 for the location of 52CS). The MBP Lamp (No.7 Lamp on Figure 2.1) will be illuminated. (Do not rotate MBS (52CS) if the load is NOT fed by bypass source).
4. After 3 seconds, rotate 52CS clockwise to the "BYPASS" position.
5. Transfer complete. Load is fed from the external source (Utility or generator).

B) Transfer of load from maintenance bypass to inverter

1. Confirm that the Static Bypass line is on and energized.
2. Rotate MBS(52CS) counterclockwise from the "BYPASS" position to the "TRANSFER" position, wait 5 seconds.
3. On the UPS, confirm the "LOAD ON BYPASS" LED is on. If not, stop Inverter as per the procedure of A) 1.
4. Rotate MBS(52CS) counterclockwise to the "NORMAL" position.
5. Close the external input breaker. Confirm that the converter operates and DC contactor 72B closes.
6. Press "START" button on the LCD panel to transfer the load to inverter source. The "LOAD ON INVERTER" LED will be illuminated.
7. Transfer complete. Load now powered by the inverter.

3.6 Operating Procedures for Multi Module System



CAUTION: *To avoid parallel operation between the bypass source of one module and an inverter source of another module, which may result large cross current between the two modules, **DO NOT OPERATE THE MAINTENANCE BYPASS SWITCH BUILT IN EACH UPS MODULE UNDER PARALLEL OPERATION (Must be kept in NORMAL position).***

3.6.1 System Maintenance Bypass Operation to Normal Operation (MMS Start Up)

A) Verification of Critical Load Cabinet (CLC) and circuit breaker status



Note: *Follow CLC instructions for detailed procedures below. Instructions 1 and 2 apply for CLC with built in SMB only.*

1. Verify that Critical Load Cabinet (CLC) Circuit Breaker SMB is closed.
2. Verify that CLC System Output Circuit Breaker 52L is open.
3. Verify that CLC UPS Circuit Breakers 52L1 and 52L2 are closed.

B) MMS Start-up Procedure

Start-up of UPS-1

1. Verify that the maintenance bypass switch 52CS is in "NORMAL" position
2. Close External AC and Bypass Input Circuit Breaker (User supplied).
3. The "LOAD ON BYPASS." LED turns on and power is supplied to the critical load from the static bypass line automatically.
4. .Within ten (10) seconds, the "LOAD ON INVERTER" LED flashes and the Inverter starts. The UPS will automatically transfer the load from the static bypass line to the inverter and the "LOAD ON INVERTER" light turns on.

Start-up of UPS-2

1. Verify that the maintenance bypass switch 52CS is in “NORMAL” position
2. Close External AC and Bypass Input Circuit Breaker (User supplied).
UPS inverter will start automatically, synchronize with the UPS-1 inverter, then output contactor (52C) will automatically close.
UPS Parallel operation complete, load is powered by the MMS inverter.
3. Verify there are no alarms on each UPS LCD.

3.6.2 Normal Operation to System Maintenance Bypass Operation**A) Transfer from UPS MMS Inverter Operation to UPS MMS Bypass Operation**

1. Transfer the MMS system to UPS MMS Bypass Operation by stopping each UPS Module inverter at each UPS Module individually (Inverter Stop operation as shown in section 3.4 B 1 and 2)

B) Transfer of Load from MMS Bypass Operation to Maintenance Bypass Operation

1. Verify UPS System is in UPS MMS Bypass Operation mode.
2. Transfer load from CLC System Output Circuit Breaker 52L to CLC Maintenance Bypass Circuit Breaker SMB.



WARNING : *Verify the load is OFF if the next step is to be performed.*

If system shutdown is required, open all External AC and Bypass Input Circuit Breakers (User supplied) of UPS-1 and UPS-2.

3.6.3 System Maintenance Bypass Operation to Inverter Operation

1. Verify UPS System is in UPS MMS Bypass Operation mode.
2. Transfer load from CLC Maintenance Bypass Circuit Breaker SMB to CLC System Output Circuit Breaker 52L.
3. At each UPS, press “START” button on the LCD panel to transfer the load to inverter source. The “LOAD ON INVERTER” LED will be illuminated.

4.0 RESPONSE TO UPS FAILURE

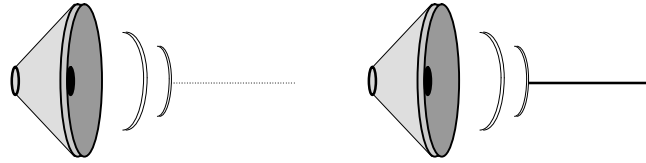
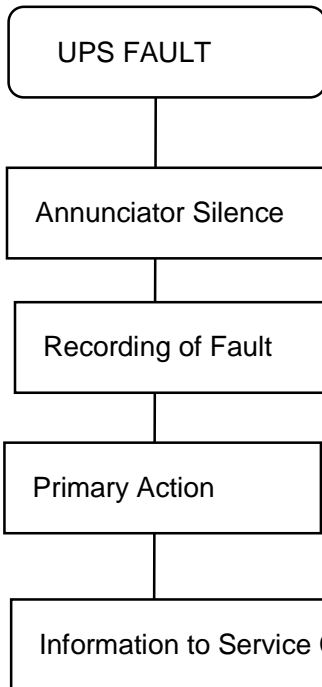

Depress "SILENCE ALARM" key on MAIN menu.

Refer to the list of fault codes in section 6.0 for error description.

Take necessary action according to display guidance.

When a faults occur, contact the Authorized Mitsubishi Service Representative or call Mitsubishi at **1-800-887-7830**.



Note

The error code indicated on the LCD display panel at the time of a UPS alarm condition is very important.

In order to reduce repair time, please include this information, along with the operation status and load status for all correspondence with Mitsubishi's field service group.

5.0 PARTS REPLACEMENT

Contact Mitsubishi or its Authorized Service Center on all issues regarding the replacement of parts.

A) Battery

Battery lifetime may vary according to the frequency of use and the average ambient operating temperature. The end of battery life is defined as the state of charge resulting in an ampere-hour capacity less than, or equal to, 80% of nominal capacity. Replace battery if its capacity is within this percentage.

B) UPS Component Parts

Contact Mitsubishi or its Authorized Service Center for a complete parts replacement schedule. Recommended replacement time interval varies with operating environment. Contact Mitsubishi or its Authorized Service Center for application specific recommendations.

6.0 FAULT CODES

This section covers fault codes, their description and required action.

At time of error :

- A) Verify and record the occurrence of the alarm. Note details of alarm message displayed on the LCD display panel.

Contact Mitsubishi Electric Power Products, Inc. at 1-800-887-7830.

- B) If a circuit breaker (MCCB) has tripped, depress the toggle to reset the breaker before closing it again.

Failure Table 6.1 Fault Code

Code List

(Note 9) Code indication	Status message	Contents	Guidance	(Note 1) Buzzer	(Note 2) External send-out contact	(Note 3) Failure lamp
UF003	CONVERTER ABNORMAL	Preliminary charge impossible	CALL SERVICE ENGINEER	[1]	Major	Lit on
UF006	CONVERTER ABNORMAL	Mixed operation (2 minutes)	CALL SERVICE ENGINEER	[1]	Major	Lit on
UF055	CONVERTER ABNORMAL	Mixed operation (1 minute)	CALL SERVICE ENGINEER	[2]	Minor	Flicker
UF056	CONVERTER OVERCURRENT	IROC (C.F. 2.5) occurred 4 times in one minute	CALL SERVICE ENGINEER	[2]	Minor	Flicker
UF102	DC OVERVOLTAGE	Over voltage of DC voltage	CALL SERVICE ENGINEER	[1]	Major	Lit on
UF103	DC UNDERVOLTAGE	Low voltage of DC voltage	CALL SERVICE ENGINEER	[1]	Major	Lit on
UF108	CHOPPER OVERCURRENT	Chopper output overcurrent	CALL SERVICE ENGINEER	[1]	Major	Lit on
UF151	DC VOLTAGE ABNORMAL	Continuous +/-2% deviation of float voltage under charging mode for 36 hrs	CALL SERVICE ENGINEER	[2]	Minor	Flicker
UF152	DC VOLTAGE ABNORMAL	Does not return to equalizing voltage after power supply is resumed	CALL SERVICE ENGINEER	[2]	Minor	Flicker
UF156	72B TRIPPED (BATTERY OVERTEMP.)	Battery temperature abnormality (UF157) lasted a long time (Note 5)	CHECK BATTERY	[2]	Minor	Flicker
UF157	BATTERY OVERTEMPERATURE	Battery temperature abnormality	CHECK BATTERY	[2]	Minor (Note 4)	Flicker
UF161	72B TRIPPED (DC VOLT. ABNORMAL)	Continuous condition of UF151 for more than 12 hrs.	CALL SERVICE ENGINEER	[2]	Minor	Flicker
UF162	BATTERY ABNORMAL	Battery abnormal detected by battery self test.	CALL SERVICE ENGINEER	[2]	Minor	Flicker
UF163	BATTERY VOLTAGE ABNORMAL	Battery voltage abnormality	CALL SERVICE ENGINEER	[2]	Minor	Flicker
UF201	INVERTER OVERVOLTAGE	Output overvoltage during inverter power supply (+ 15%)	CALL SERVICE ENGINEER	[1]	Major	Lit on
UF202	INVERTER UNDERVOLTAGE	Output low voltage during inverter supply (-15%)	CALL SERVICE ENGINEER	[1]	Major	Lit on
UF203	INVERTER OVERCURRENT	Inverter output overcurrent	CALL SERVICE ENGINEER	[1]	Major	Lit on
UF209	52C ABNORMAL	52C not turned ON	CALL SERVICE ENGINEER	[1]	Major	Lit on
UF210	52C ABNORMAL	52C not turned OFF	CALL SERVICE ENGINEER	[1]	Major	Lit on

(Note 9) Code indication	Status message	Contents	Guidance	(Note 1) Buzzer	(Note 2) External send-out contact	(Note 3) Failure lamp
UF213	INV. OR CONV. OVERTEMPERATURE	Overheating of main circuit parts	CALL SERVICE ENGINEER	[1]	Major	Lit on
UF214	COOLING FAN ABNORMAL	Abnormality of cooling fan inside panel	CALL SERVICE ENGINEER	[1]	Major	Lit on
UF255	52C ABNORMAL	52C turned OFF during inverter power supply	CALL SERVICE ENGINEER	[2]	Minor	Flicker
UF256	OUTPUT VOLTAGE ABNORMAL	Inverter output voltage fell out of +/- 5%	CALL SERVICE ENGINEER	[2]	Minor	Flicker
UF258	LOAD ABNORMAL	More than 4 overcurrent transfers in 5 minutes	CALL SERVICE ENGINEER	[2]	Minor	Flicker
UF259	ANOTHER UPS ABNORMAL	Inverter output voltage bus abnormality	CALL SERVICE ENGINEER	[2]	Minor	Flicker
UF301	UPS CONTROL CIRCUIT ERROR	Control microcomputer abnormality	CALL SERVICE ENGINEER	[1]	Major	Lit on
UF302	UPS CONTROL CIRCUIT ERROR	Control microcomputer abnormality	CALL SERVICE ENGINEER	[1]	Major	Lit on
UF303	UPS CONTROL CIRCUIT ERROR	Control microcomputer abnormality	CALL SERVICE ENGINEER	[1]	Major	Lit on
UF305	UPS CONTROL CIRCUIT ERROR	Control clock abnormality	CALL SERVICE ENGINEER	[1]	Major	Lit on
UF306	UPS CONTROL CIRCUIT ERROR	Control power source circuit abnormality	CALL SERVICE ENGINEER	[1]	Major	Lit on
UF309	INVERTER VOLTAGE ABNORMAL	Inverter output voltage abnormality before inverter power supply	CALL SERVICE ENGINEER	[1]	Major	Lit on
UF310	UPS CONTROL CIRCUIT ERROR	Control microcomputer abnormality	CALL SERVICE ENGINEER	[1]	Major	Lit on
UF349	UPS CONTROL CIRCUIT ERROR	Control microcomputer abnormality	CALL SERVICE ENGINEER	[1]	Major	Lit on
UF371	UPS CONTROL CIRCUIT ERROR	Control microcomputer abnormality	CALL SERVICE ENGINEER	[2]	Minor	Flicker
UF372	UPS CONTROL CIRCUIT ERROR	Control microcomputer abnormality	CALL SERVICE ENGINEER	[2]	Minor	Flicker
UF373	UPS CONTROL CIRCUIT ERROR	Control microcomputer abnormality	CALL SERVICE ENGINEER	[2]	Minor	Flicker
UF453	52L OPERATION ERROR	52L operated abnormally	CHECK 52L	[2]	Minor	Flicker
UA801	AC INPUT VOLTAGE OUT OF RANGE	AC input voltage deviates from +17% to -32% range	CHECK INPUT POWER SOURCE	[2]	Alarm	-
UA803	INPUT PHASE ROTATION ERROR	Input phase abnormal	CHECK INPUT POWER SOURCE	[2]	Alarm	-

(Note 9) Code indication	Status message	Contents	Guidance	(Note 1) Buzzer	(Note 2) External send-out contact	(Note 3) Failure lamp
UA806	INVERTER OVERLOAD > 100%	Overload exceeded 105% (Note 7)	WARNING: DECREASE LOAD	[2]	Alarm	-
UA809	INVERTER OVERLOAD > 150%	Overload exceeded 150% (Note 7)	WARNING: DECREASE LOAD	[2]	Alarm	-
UA810	INVERTER OVERLOAD	Instantaneous overload. (Output voltage -30% for 2ms)	WARNING: DECREASE LOAD	[2]	Alarm	-
UA812	BYPASS VOLTAGE OUT OF RANGE	Bypass voltage fell out of +/- 12% range	CHECK BYPASS INPUT	[3]	Alarm	-
UA813	BYPASS PHASE ROTATION ERROR	Phase rotation is inverted when bypass voltage is normal	CHECK BYPASS INPUT	[2]	Alarm	-
UA814	BYPASS FREQUENCY OUT OF RANGE	Bypass frequency fell out of inverter synchronization follow-up range	CHECK BYPASS INPUT	[3]	Alarm	-
UA817	EMERGENCY STOP ACTIVATED	Emergency stop applied	-	-	Alarm	-
UA832	ASYNCHRONOUS TRANSFER	Asynchronous transfer occurred	-	[2]	Alarm	-
UA834	BATTERY DEPLETED AC OUT STOPPED	DC voltage dropped below discharge end during inverter operation	-	-	Alarm	-
UA835	BATTERY DEPLETED AND RESTART	Restart after battery depleted	-	-	Alarm	-
UA852	INVERTER OVERLOAD	Total of more than 110% load during MMS operation.	WARNING: DECREASE LOAD	[2]	Alarm	-
UA853	RETRY START OPERATION	Continuous bypass voltage abnormal, inverter stop, and 72B closed for 1 min. will stop the UPS. (Fan stop)		[2]	Alarm	-

(Note 1)

Audible annunciator: [1] continuous sound, [2] intermittent sound
[3] intermittent sound (May be canceled by option settings)

(Note 2)

- (a) "Major" is defined as major failure. Inverter transferred to the static bypass line
- (b) "Minor" is defined as a minor failure. UPS continues to operate normally, but cause of alarm must be identified

(Note 3)

Indicates one of two possible LED illumination patterns - continuously on (lit) or intermittent (flicker).

(Note 4)

External send-out possible by option setting.

(Note 5)

Trips the battery breaker 72B.

(Note 6)

For other than sealed-type battery.

(Note 7)

If the specified time elapses, will transfer to the bypass power supply.

(Note 8)

Shows only when corresponding option settings are made.

(Note 9)

Code indication means:

UA+++----- Alarm
UF+++----- Failure
U%0++----- Converter circuit failure
U%1++----- DC circuit failure
U%2++----- Inverter circuit failure
U%3++----- Control circuit failure
U%4++----- Bypass system failure
U%8++----- Alarm
U%+00 - U%+49 ----- Major failure
U%+50 - U%+99 ----- Minor failure

*) "+" denotes any numeral from 0 to 9

*) "%" denotes either "A" or "F"

7.0 Warranty & Out of warranty Service

The Mitsubishi Electric UPS Division Service Department has many Authorized Service Centers place strategically throughout the US, Canada and Latin America. For both in warranty and out of warranty service, please contact Mitsubishi Electric Power Products, Inc. at (847) 478-2500. To register your UPS for warranty purposes, please complete the warranty registration form and fax it to the Mitsubishi Electric UPS Division Service Department fax line shown on the registration form. (Next page)

For warranty purposes, it is essential that any and all service work that may be required on your Mitsubishi brand UPS equipment is performed by a Mitsubishi Electric Authorized Service Center. The use of non-authorized service providers may void your warranty.

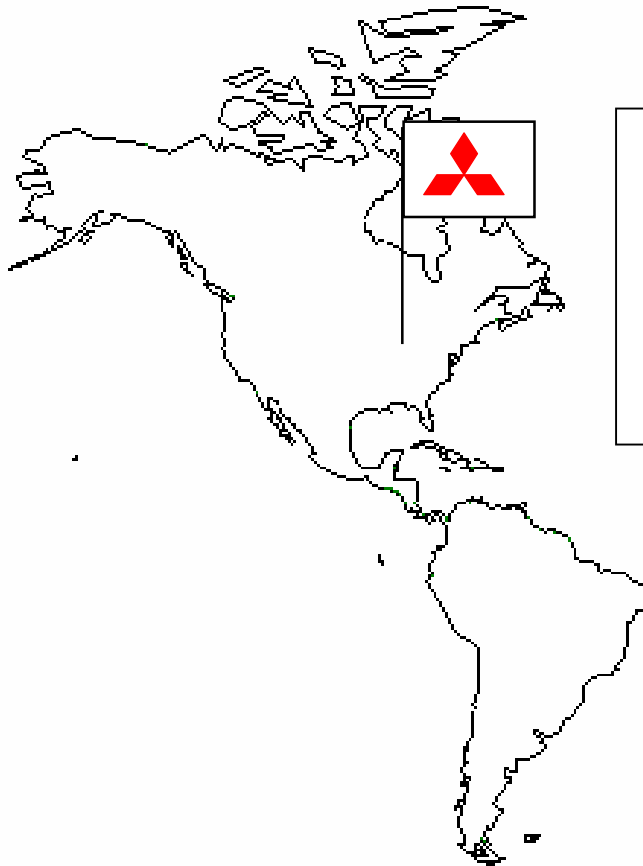

Mitsubishi Electric Power Products Inc,
UPS Division Service Department

500 Corporate Woods Parkway,
Vernon Hills, Illinois 60061, USA
Phone: (847) 478-2500
Fax: (847) 478-7830

Mitsubishi Electric Power Products, Inc.
UNINTERRUPTIBLE POWER SUPPLIES

500 Corporate Woods Parkway, Vernon Hills, IL 60061 Phone: (847) 478-2500, Fax: (847) 478-2290

UPS Warranty Registration

 Register UPS for Warranty

 Address Change

To validate the Warranty on your UPS this form must be filled out completely by Customer and returned.

CUSTOMER INFORMATION		
Your Name:	Job Title:	
Company Name:		
Division / Department:		
Address:		
City:	State:	Zip Code:
Country:		Province:
Business Phone:	Ext:	Fax:
E-Mail: _____ @ _____		Internet Address:
UPS Model #:	Capacity (kVA):	UPS Serial #:
Start-Up Date: / /	Authorized Mitsubishi Service Company (if known):	
Signature: _____		Date: / /

Which ONE of These Best Describes Your Organization's Primary Business Classification?

- {Energy Producer}
 - Utility
 - Alternate Energy
- {Manufacturing Co.}
 - OEM
 - Process
 - Consumer Goods
 - Electronics
 - Power Quality Equipment
- Commercial Business
- Electrical Contractor
- Healthcare
- Internet

- Education/Univ. Service
- {Service}
 - Consulting
 - Engineering
 - Outsourcing
 - Financial/Legal/Insurance
- {Government}
 - Military
 - Municipals
 - Federal/State/Local
- Communications
- Distributors/Reps
- Other _____

Number of Employees at This Location is:

- 1 - 19
- 100 - 249
- 1000 or more
- 20 - 49
- 250 - 499
- 500 - 999
- 50 - 99

Overall how was Start-Up performed:

-
- Unsatisfactory
-
- Satisfactory
-
- Exceeded

Would you like to receive future product updates and news?

-
- Yes
-
- No

**After Start-Up has been done Fax completed Form to:
(847) 478-2290**

NOTE: PLEASE READ THE TERMS OF THIS LIMITED WARRANTY CAREFULLY PRIOR TO INSTALLATION AND START-UP OF YOUR NEW MITSUBISHI UNINTERRUPTIBLE POWER SUPPLY SYSTEM. FAILURE TO FOLLOW THESE PROCEDURES MAY VOID YOUR LIMITED WARRANTY!

**MITSUBISHI ELECTRIC POWER PRODUCTS, INC.
UNINTERRUPTIBLE POWER SUPPLY SYSTEM
(2033A/2033C/2033D/9700/9800A SERIES)
LIMITED WARRANTY POLICY AND PROCEDURES**

1. LIMITED WARRANTY: MITSUBISHI ELECTRIC POWER PRODUCTS, INC. ("MEPPI") warrants to the original end user that the 2033A/2033C/2033D/9700/9800A series Uninterruptible Power Supply Unit sold by MEPPI (the "Product") shall be free from defects in material and workmanship under normal use and service for a period of twenty four(24) months from the date of installation or thirty (30) months from the date of shipment of the Product, whichever comes first, the original end user (the "Warranty Period"). If MEPPI receives notice of any defects during the Warranty Period, MEPPI shall, at its option, repair or replace any defective parts, subject to the limitations and procedures described below.

A. LIMITATIONS. This Limited Warranty shall cover the Product only if all of the following conditions have been met:

- (1) If temporary on-site storage of the Product was required before installation, all prescribed storage requirements as set forth in MEPPI's published storage guidelines shall have been strictly followed.
- (2) MEPPI's UPS Divisions Service Department or a MEPPI Authorized Service Organization shall have inspected the installation site to determine correct application conditions and to perform any required inspections, calibrations and startup of the Product. Contact MEPPI at the number listed below to schedule startup of the Product.
- (3) This limited warranty does not include travel and related costs for Products installed outside the United States. Consult your local MEPPI representative for terms and conditions.

B. EXCLUSIONS. This Limited Warranty does not cover:

- (1) System batteries/battery plant and all other peripheral products and accessories not manufactured by MEPPI (including components or software) or the installation, operation, maintenance or service of such accessories. These items may be separately warranted by the manufacturer of the item in question.
- (2) Any Product whose serial number has been altered defaced or removed.
- (3) Any Product which has been damaged during shipment.
- (4) Product defects caused by installation, start-up, wiring, modification, alteration, repair, service or parts replacement except by MEPPI or an authorized MEPPI service representative. Contact MEPPI at the number below for a list of authorized service providers in your area.
- (5) Product defects caused by inadequate maintenance, misuse, physical abuse of the Product, accident, excessive stress or operation of the Product under abnormal environmental conditions or contrary to the Product's operating instructions.
- (6) Product defects caused by failure to follow the operational specifications or the handling and operational procedures prescribed in the Product Owner's Manual.
- (7) Service, repair or replacement of parts made necessary by any cause beyond MEPPI's control, including, but not limited to, fire, theft, lightning, acts of God, negligence, accident, excessive physical or electrical stress or operation under abnormal environmental conditions.
- (8) Products which have been decommissioned and/or relocated from the original installation site.

C. ADDITIONAL LIMITATIONS

- (1) Parts used for replacements are warranted for the longer of 90 days or the remainder of the original Warranty Period. All defective Product parts shall be the property of MEPPI upon replacement. MEPPI reserves the right to make any or all changes to the Products that it may deem necessary without prior notice to customer. Replacement parts may be new or reconditioned or refurbished.
- (2) THIS LIMITED WARRANTY IS EXCLUSIVE, AND NO OTHER WARRANTY WHETHER WRITTEN OR ORAL, IS EXPRESSED OR IMPLIED. MEPPI SPECIFICALLY DISCLAIMS ANY IMPLIED WARRANTY OF MERCHANTABILITY AND FITNESS FOR ANY PARTICULAR PURPOSE, WHICH SHALL NOT BE APPLICABLE UNDER ANY CIRCUMSTANCES WHATSOEVER.
- (3) THIS LIMITED WARRANTY SHALL CONSTITUTE THE SOLE AND EXCLUSIVE REMEDY OF ALL PURCHASERS AND USERS OF THE PRODUCT. UNDER NO CIRCUMSTANCES SHALL MEPPI BE LIABLE FOR DAMAGES, WHETHER DIRECT, INDIRECT, SPECIAL, INCIDENTAL OR CONSEQUENTIAL BY REASON OF ANY DEFECTIVE PRODUCTS, BREACH OF THIS LIMITED WARRANTY, BREACH OF CONTRACT, TORT (INCLUDING NEGLIGENCE OR STRICT LIABILITY) OR OTHERWISE. IN NO EVENT SHALL MEPPI BE LIABLE FOR ANY AMOUNT IN EXCESS OF THE PURCHASE PRICE PAID FOR ANY PRODUCT FOUND TO BE DEFECTIVE.

2. PROCEDURES

A. Direct all inquiries to:

MITSUBISHI ELECTRIC POWER PRODUCTS, INC.
Attention: UPS Division Service Department
500 Corporate Woods Parkway
Vernon Hills, Illinois 60061
Telephone: (847) 478-2500
(800) 887-7830

B. All claims for warranty service shall be submitted to MEPPI at the address listed in 2A above. Claims shall be made in writing or by telephone or fax subsequently confirmed in writing and will be considered received on the day notice is actually received by MEPPI.

C. If MEPPI determines that the repair is covered under this Limited Warranty, MEPPI shall repair or replace the defective part at no charge to the customer. MEPPI shall advise the customer if it determines that the requested repair is not covered under this Limited Warranty. Upon customer's request, MEPPI shall perform the repair at the customer's cost and expense. Repair charges shall be based on service parts price and the prevailing field service-call charges in effect at the time of repair. All repair invoices shall be paid within 30 days of invoice date. Past due invoices shall bear interest at the rate of 1.5% per month, but not in excess of the maximum lawful rate, until paid in full. Customers are responsible for all costs and expenses, including attorneys' fees, incurred by MEPPI in collecting any past due invoices.

3. EXTENDED WARRANTY: The original end user may purchase an extension of this limited warranty for up to 36 months after the expiration of the original limited warranty. Extensions are available on new Product only (not previously placed in service) located at the site of the original end user; provided the Product has been continuously covered either by the original warranty or an extended warranty. Contact MEPPI for details prior to the expiration of your initial or extended limited warranty.

4. MODIFICATIONS: MEPPI may modify the procedures and charges described in this Limited Warranty at any time without prior notice to customer. No modification, waiver or alteration of any of the provisions of this Limited Warranty by customer shall be binding upon MEPPI, unless made in writing and signed by a duly authorized officer of MEPPI.

5. GOVERNING LAW: This Limited Warranty shall be subject to and construed solely in accordance with the laws of the United States of American and the State of Illinois, without regard to its principles of conflicts of law. The parties specifically disclaim the applicability of the United Nations Convention on the International Sale of Goods, as amended, and the United Nations Convention on the Limitation Period in the International Sale of Goods, as amended, to this Limited Warranty or any transaction or dispute arising hereunder.