

Symmetra™ PX

100 kW 208 V

Installation

Including Optional Maintenance Bypass Cabinet and Optional Modular PDU (600:208 V, 480:208 V, 208:208 V, 208 V Transformerless)

10/2014



Legal Information

The Schneider Electric brand and any registered trademarks of Schneider Electric Industries SAS referred to in this guide are the sole property of Schneider Electric SA and its subsidiaries. They may not be used for any purpose without the owner's permission, given in writing. This guide and its content are protected, within the meaning of the French intellectual property code (Code de la propriété intellectuelle français, referred to hereafter as "the Code"), under the laws of copyright covering texts, drawings and models, as well as by trademark law. You agree not to reproduce, other than for your own personal, noncommercial use as defined in the Code, all or part of this guide on any medium whatsoever without Schneider Electric's permission, given in writing. You also agree not to establish any hypertext links to this guide or its content. Schneider Electric does not grant any right or license for the personal and noncommercial use of the guide or its content, except for a non-exclusive license to consult it on an "as is" basis, at your own risk. All other rights are reserved.

Electrical equipment should be installed, operated, serviced, and maintained only by qualified personnel. No responsibility is assumed by Schneider Electric for any consequences arising out of the use of this material.

As standards, specifications, and designs change from time to time, please ask for confirmation of the information given in this publication.

Table of Contents

Important Safety Information	5
Safety Precautions	6
Electrical Safety	8
Battery Safety	9
Product Specific Safety Messages	10
Specifications	12
Specifications for Installations without PDU	12
AC Input	12
AC Output	12
Recommended Current Rating of Feeder Circuit Breakers	13
Recommended Conductor Sizes	13
Recommended Bolt and Lug Sizes	14
Specifications for Installations with PDU or Maintenance Bypass	
Cabinet	14
AC Input	14
AC Output	15
PDU Subfeed Circuit Breaker Trip Currents Merlin Gerin NSJ400 -	
STR23SP Electronic Trip Unit (400 A frame)	15
L-Frame with Micrologic 3.3 S Trip Unit (Subfeed Breaker)	16
L-Frame with Micrologic 3.3 S Trip Unit (QB 600 V Canadian	
unit)	16
L-Frame Mission Critical with Micrologic 3.3 S-W 600 A Trip Unit	16
L-Frame Mission Critical with Micrologic 3.3 S-W 400 A Trip Unit	17
Recommended Current Rating of Supply OCPD	17
Inrush Currents	17
Recommended Conductor Sizes	17
Batteries	18
Heat Dissipation	19
Mechanical Assembly	20
Rearrange the Side Panels	20
Remove the Side Panels	20
Install the Side Panels	20
Install the Internal Conductors for Bottom Entry Systems in Installations with	
PDU without Transformer	21
Perform Equipotential Bonding	22
Interconnect and Level the Cabinets	22
Connect Power Conductors and Communication Cables	25
Procedure for System without PDU	25
Prepare for Cables – Systems without PDU	25
Connect Power Conductors – Systems without PDU	28
Connect Maintenance Bypass Cabinet (Option)	30
Connect Communication Wires – Systems without PDU	39
Procedure for Systems with PDU without Transformer	41
Overview of Single Utility System with Top Cable Entry	41
Overview of Single Utility System with Bottom Cable Entry	41
Overview of Dual Utility System with Top Cable Entry	42
Overview of Dual Utility System with Bottom Cable Entry	42

Prepare for Cables – Systems with PDU without Transformer.....	43
Connect Power Conductors – Systems with PDU without Transformer	
— Top Cable Entry	48
Connect Power Conductors – Systems with PDU without Transformer	
— Bottom Cable Entry.....	50
Connect Power Conductors between the UPS and the PDU.....	52
Connect Communication Wires in Installations with PDU	59
Procedure for Systems with PDU with Transformer	60
Overview of Single Utility System with Top Cable Entry	60
Overview of Single Utility System with Bottom Cable Entry.....	61
Overview of Dual Utility System with Top Cable Entry	61
Overview of Dual Utility System with Bottom Cable Entry	62
Prepare for Cables – Systems with PDU with Transformer	63
Connect Power Conductors – Systems with PDU with	
Transformer.....	69
Connect Power Conductors between the UPS and the PDU.....	71
Connect Communication Wires in Installations with PDU	79
Connect Network Communication Cable	80
Install the Symmetra PX Modular Battery Cabinet	81
Connect the Battery Cables between the Modular Battery Cabinets.....	81
Connect the Battery Cables to the UPS	85
Emergency Power Off (EPO) Switch	86
Options	89
Install Shunt Trip in Circuit Breaker QB in PDU (Option).....	89
Install Seismic Option	94
Replace the Side Panel Lock	94
Install the Rear Anchoring Brackets.....	97
Install the Front Anchoring Bracket.....	98
Install the Top Assembly Bracket.....	99
Install the Door Hinge Lock	99
Install the Battery Locks	101
Alternative Use of the Sidecar.....	101

Important Safety Information

Read these instructions carefully and look at the equipment to become familiar with it before trying to install, operate, service or maintain it. The following safety messages may appear throughout this manual or on the equipment to warn of potential hazards or to call attention to information that clarifies or simplifies a procedure.



The addition of this symbol to a “Danger” or “Warning” safety message indicates that an electrical hazard exists which will result in personal injury if the instructions are not followed.



This is the safety alert symbol. It is used to alert you to potential personal injury hazards. Obey all safety messages with this symbol to avoid possible injury or death.

⚠ DANGER
DANGER indicates a hazardous situation which, if not avoided, will result in death or serious injury.
Failure to follow these instructions will result in death or serious injury.
⚠ WARNING
WARNING indicates a hazardous situation which, if not avoided, could result in death or serious injury.
Failure to follow these instructions can result in death, serious injury, or equipment damage.
⚠ CAUTION
CAUTION indicates a hazardous situation which, if not avoided, could result in minor or moderate injury.
Failure to follow these instructions can result in injury or equipment damage.
NOTICE
NOTICE is used to address practices not related to physical injury. The safety alert symbol shall not be used with this type of safety message.
Failure to follow these instructions can result in equipment damage.

Please Note

Electrical equipment should only be installed, operated, serviced, and maintained by qualified personnel. No responsibility is assumed by Schneider Electric for any consequences arising out of the use of this material.

A qualified person is one who has skills and knowledge related to the construction, installation, and operation of electrical equipment and has received safety training to recognize and avoid the hazards involved.

Safety Precautions

⚠ DANGER

HAZARD OF ELECTRIC SHOCK, EXPLOSION, OR ARC FLASH

All safety instructions in this document must be read, understood and followed.

Failure to follow these instructions will result in death or serious injury.

⚠ DANGER

HAZARD OF ELECTRIC SHOCK, EXPLOSION, OR ARC FLASH

Read all instructions in the Installation Manual before installing or working on this UPS system.

Failure to follow these instructions will result in death or serious injury.

⚠ DANGER

HAZARD OF ELECTRIC SHOCK, EXPLOSION OR ARC FLASH

Do not install the UPS system until all construction work has been completed and the installation room has been cleaned.

Failure to follow these instructions will result in death or serious injury.

⚠ DANGER

HAZARD OF ELECTRIC SHOCK, EXPLOSION, OR ARC FLASH

- The product must be installed according to the specifications and requirements as defined by Schneider Electric. It concerns in particular the external and internal protections (upstream breakers, battery breakers, cabling, etc.) and environmental requirements. No responsibility is assumed by Schneider Electric if these requirements are not respected.
- After the UPS system has been electrically wired, do not start up the system. Startup must only be performed by Schneider Electric.

Failure to follow these instructions will result in death or serious injury.

⚠ DANGER**HAZARD OF ELECTRIC SHOCK, EXPLOSION, OR ARC FLASH**

The UPS System must be installed according to local and national regulations. Install the UPS according to:

- IEC 60364 (including 60364-4-41 - protection against electric shock, 60364-4-42 - protection against thermal effect, and 60364-4-43 - protection against overcurrent), **or**
- NEC NFPA 70, **or**
- Canadian Electrical Code (C22.1, Part 1)

depending on which one of the standards apply in your local area.

Failure to follow these instructions will result in death or serious injury.

⚠ DANGER**HAZARD OF ELECTRIC SHOCK, EXPLOSION OR ARC FLASH**

- Install the UPS system in a temperature controlled environment free of conductive contaminants and humidity.
- Install the UPS system on a non-inflammable, level and solid surface (e.g. concrete) that can support the weight of the system.

Failure to follow these instructions will result in death or serious injury.

⚠ DANGER**HAZARD OF ELECTRIC SHOCK, EXPLOSION OR ARC FLASH**

The UPS is not designed for and must therefore not be installed in the following unusual operating environments:

- Damaging fumes
- Explosive mixtures of dust or gases, corrosive gases, or conductive or radiant heat from other sources
- Moisture, abrasive dust, steam or in an excessively damp environment
- Fungus, insects, vermin
- Salt-laden air or contaminated cooling refrigerant
- Pollution degree higher than 2 according to IEC 60664-1
- Exposure to abnormal vibrations, shocks, and tilting
- Exposure to direct sunlight, heat sources, or strong electromagnetic fields

Failure to follow these instructions will result in death or serious injury.

⚠ DANGER**HAZARD OF ELECTRIC SHOCK, EXPLOSION, OR ARC FLASH**

Do not drill/punch holes for cables or conduits with the gland plates installed and do not drill/punch in close proximity to the UPS.

Failure to follow these instructions will result in death or serious injury.

⚠ WARNING**HAZARD OF ARC FLASH**

Do not make mechanical changes to the product (including removal of cabinet parts or drilling/cutting of holes) that are not described in the Installation Manual.

Failure to follow these instructions can result in death, serious injury, or equipment damage.

⚠ WARNING**HAZARD OF OVERHEATING**

Respect the space requirements around the UPS system and do not cover the product's ventilation openings when the UPS system is in operation.

Failure to follow these instructions can result in death, serious injury, or equipment damage.

⚠ WARNING**HAZARD OF EQUIPMENT DAMAGE**

Do not connect the UPS output to regenerative load systems including photovoltaic systems and speed drives.

Failure to follow these instructions can result in death, serious injury, or equipment damage.

Electrical Safety**⚠ DANGER****HAZARD OF ELECTRIC SHOCK, EXPLOSION OR ARC FLASH**

- Electrical equipment must be installed, operated, serviced, and maintained only by qualified personnel.
- The UPS system must be installed in a room with restricted access (qualified personnel only).
- Apply appropriate personal protective equipment (PPE) and follow safe electrical work practices.
- Turn off all power supplying the UPS system before working on or inside the equipment.
- Before working on the UPS system, check for hazardous voltage between all terminals including the protective earth.
- The UPS contains an internal energy source. Hazardous voltage can be present even when disconnected from the utility/mains supply. Before installing or servicing the UPS system, ensure that the units are OFF and that utility/mains and batteries are disconnected. Wait five minutes before opening the UPS to allow the capacitors to discharge.
- A disconnection device (e.g. disconnection circuit breaker or switch) must be installed to enable isolation of the system from upstream power sources in accordance with local regulations. This disconnection device must be easily accessible and visible.
- The UPS must be properly earthed/grounded and due to a high leakage current, the earthing/grounding conductor must be connected first.

Failure to follow these instructions will result in death or serious injury.

⚠ DANGER**HAZARD OF ELECTRIC SHOCK, EXPLOSION, OR ARC FLASH**

In systems where backfeed protection is not part of the standard design, an automatic isolation device (backfeed protection option or other device meeting the requirements of IEC/EN 62040-1 or UL1778 4th Edition – depending on which of the two standards apply to your local area) must be installed to prevent hazardous voltage or energy at the input terminals of the isolation device. The device must open within 15 seconds after the upstream power supply fails and must be rated according to the specifications.

Failure to follow these instructions will result in death or serious injury.

When the UPS input is connected through external isolators that, when opened, isolate the neutral or when the automatic backfeed isolation is provided external to the equipment or is connected to an IT power distribution system, a label must be fitted at the UPS input terminals, and on all primary power isolators installed remote from the UPS area and on external access points between such isolators and the UPS, by the user, displaying the following text (or equivalent in a language which is acceptable in the country in which the UPS system is installed):

⚠ DANGER**HAZARD OF ELECTRIC SHOCK, EXPLOSION, OR ARC FLASH**

Risk of Voltage Backfeed. Before working on this circuit: Isolate the UPS and check for hazardous voltage between all terminals including the protective earth.

Failure to follow these instructions will result in death or serious injury.

Battery Safety

⚠ DANGER**HAZARD OF ELECTRIC SHOCK, EXPLOSION OR ARC FLASH**

- Battery circuit breakers must be installed according to the specifications and requirements as defined by Schneider Electric.
- Servicing of batteries must only be performed or supervised by qualified personnel knowledgeable of batteries and the required precautions. Keep unqualified personnel away from batteries.
- Disconnect charging source prior to connecting or disconnecting battery terminals.
- Do not dispose of batteries in a fire as they can explode.
- Do not open, alter, or mutilate batteries. Released electrolyte is harmful to the skin and eyes. It may be toxic.

Failure to follow these instructions will result in death or serious injury.

⚠ DANGER**HAZARD OF ELECTRIC SHOCK, EXPLOSION, OR ARC FLASH**

Batteries can present a risk of electric shock and high short-circuit current. The following precautions must be observed when working on batteries

- Remove watches, rings, or other metal objects.
- Use tools with insulated handles.
- Wear protective glasses, gloves and boots.
- Do not lay tools or metal parts on top of batteries.
- Disconnect the charging source prior to connecting or disconnecting battery terminals.
- Determine if the battery is inadvertently grounded. If inadvertently grounded, remove source from ground. Contact with any part of a grounded battery can result in electric shock. The likelihood of such shock can be reduced if such grounds are removed during installation and maintenance (applicable to equipment and remote battery supplies not having a grounded supply circuit).

Failure to follow these instructions will result in death or serious injury.

⚠ DANGER**HAZARD OF ELECTRIC SHOCK, EXPLOSION, OR ARC FLASH**

When replacing batteries, always replace with the same type and number of batteries or battery packs.

Failure to follow these instructions will result in death or serious injury.

⚠ CAUTION**RISK OF EQUIPMENT DAMAGE**

- Wait until the system is ready to be powered up before installing batteries in the system. The time duration from battery installation until the UPS system is powered up must not exceed 72 hours or 3 days.
- Batteries must not be stored more than six months due to the requirement of recharging. If the UPS system remains de-energized for a long period, we recommend that you energize the UPS system for a period of 24 hours at least once every month. This charges the batteries, thus avoiding irreversible damage.

Failure to follow these instructions can result in injury or equipment damage.

Product Specific Safety Messages**⚠ DANGER****HAZARD OF ELECTRIC SHOCK, EXPLOSION, OR ARC FLASH**

The UPS system does not have built-in disconnection devices for AC input/output and DC input. The customer must provide AC input/output over-current protection and an AC output disconnect device.

Failure to follow these instructions will result in death or serious injury.

⚠ DANGER**HAZARD OF ELECTRIC SHOCK, EXPLOSION, OR ARC FLASH**

The sidecar (model PDPM100SC) is required for underfloor wiring into the PDU when the PDU contains a transformer. The sidecar does not contain a switch or circuit breaker, so a readily accessible disconnect device shall be incorporated external to the equipment.

Failure to follow these instructions will result in death or serious injury.

Specifications

NOTE: All current values are based on a 100 kW maximum configuration of the UPS.

Specifications for Installations without PDU

AC Input

NOTE: Delta input is not permitted.

	208 V UPS only
Connection type, single feed	3PH + N + G
Connection type, dual feed	Input: 3PH + G Bypass: 3PH + N + G
Input frequency (Hz)	50 or 60
Input frequency range (Hz)	40–70 with 10 Hz/sec slew rate
Nom. input current (A) ¹	296
Max. input current at low charge rate – 10% (A) ²	327
Max. input current at high charge rate – 20% (A) ²	332
Input current limit (A) ³	360
Nom. bypass input current (A)	278
Total Harmonic Distortion (THDI)	< 5% at full load (symmetrical)
Maximum short circuit withstand (kA) ⁴	30

AC Output

	208 V UPS only
Connection type	3PH + N + G or 3PH + G
Nominal output current (A)	278

1. Input current based on nominal voltage and rated load, batteries fully charged.
2. Input current based on full battery recharge, nominal voltage and rated load.
3. Current limitation through electronic current limiting is based on full rated load and limited battery recharge from -10% to -15% input voltage.
4. The maximum short circuit withstand was not evaluated by Underwriters Laboratories.

Recommended Current Rating of Feeder Circuit Breakers

⚠ DANGER

HAZARD OF ELECTRIC SHOCK, EXPLOSION OR ARC FLASH

Connect only to a circuit provided with (see below) amperes maximum branch circuit overcurrent protection in accordance with the National Electric Code, NSI/ NFPA 70.

Failure to follow these instructions will result in death or serious injury.

	208 V UPS only	
	Standard rated (80%)	100% rated
Input (A)	450	400
Bypass (A)	350	300
Battery (A)	350	300
Output (A)	350	300

Recommended Conductor Sizes

⚠ DANGER

HAZARD OF ELECTRIC SHOCK, EXPLOSION OR ARC FLASH

The product must be installed according to the specifications and requirements as defined by Schneider Electric. It concerns in particular the external and internal protections (upstream circuit breakers, battery circuit breakers, cabling, etc.) and environmental requirements. No responsibility is assumed by Schneider Electric if these requirements are not respected.

Failure to follow these instructions will result in death or serious injury.

NOTE: Maximum allowable conductor size: 500 kcmil.

Conductor sizing in this manual is based on Table 310-16 of the National Electrical Code (NEC) with the following assertions.

- 90°C conductors (THHN) for 75°C termination
- 3 current carrying conductors
- An ambient temperature of 30°C
- Use only copper conductors

If the ambient room temperature is greater than 30°C, larger conductors are to be selected in accordance with the correction factors of the NEC.

Equipment Grounding Conductors (EGC) are sized in accordance with NEC Article 250-122 and Table 250-122.

The conductor sizes are recommendations for maximum configurations. Even if the load is less than the maximum rating, it is wise to plan for future load increases. If the system is operated at a lower load than its rating and it is desired to supply the system with a lower rated breaker and smaller conductors, conductor ampacities are to be selected in accordance with the NEC.

	208 V UPS only	
	Standard rated (80%)	100% rated
Input	2 x 4/0 AWG	500 kcmil

	208 V UPS only	
	Standard rated (80%)	100% rated
Bypass	500 kcmil	300 kcmil
Battery	500 kcmil	300 kcmil
Output	500 kcmil	300 kcmil
Equipment Grounding Conductor	3 AWG	3 AWG

Recommended Bolt and Lug Sizes

Cable	Terminal Bolt Diameter	Cable Lug Type		Crimping tool CT-720 Crimping Die:	
		80% rated	100% rated	80% rated	100% rated
Input	M10	LCA4/0-12H-X	LCA500-12H-X	CD-720-3	CD-720-7
Bypass	M10	LCA500-12H-X	LCA300-12H-X	CD-720-7	CD-720-4
Battery 1	M10	–	LCA300-12H-X	–	CD-720-4
Battery 2	M10	–	LCA300-12H-X	–	CD-720-4
Output	M10	LCA500-12H-X	LCA300-12H-X	CD-720-7	CD-720-4

Specifications for Installations with PDU or Maintenance Bypass Cabinet

AC Input

	208 V : 208 V	480 V : 208 V	600 V : 208 V	Maintenance bypass cabinet or PDU without transformer
Connection type	3PH + G + GEC			L1 + L2 + L3 + N + G
Nom. input frequency (Hz)	57-63			40-70
Nom. input current (A) ⁵	302	131	104	297
Max. input current at low charge rate – 10% (A) ⁶	332	144	115	327
Max. input current at high charge rate – 20% (A) ⁶	337	146	117	332
Input current limit (A) ⁷	366	165	127	360

5. Input current based on nominal voltage and rated load, batteries fully charged.

6. Input current based on full battery recharge, nominal voltage and rated load.

7. Current limitation through electronic current limiting is based on full rated load and limited battery recharge from -10% to -15% input voltage.

	208 V : 208 V	480 V : 208 V	600 V : 208 V	Maintenance bypass cabinet or PDU without transformer
Nom. bypass input current (A)	282	122	98	278
Maximum short circuit withstand (kA) ⁸	65	65	25	30

AC Output

	208 V : 208 V	480 V : 208 V	600 V : 208 V	Maintenance bypass cabinet or PDU without transformer
Connection type	4-wire (3PH + N + G) or 3-wire (3PH + G)			
Output voltage	3 x 208/120 V			
Nom. output current (A)	278	278	278	278
Power distribution modules (not included)	20 A, 30 A, 50 A, 60 A			
Subfeed	278 A maximum (included) see following table			

PDU Subfeed Circuit Breaker Trip Currents Merlin Gerin NSJ400 - STR23SP Electronic Trip Unit (400 A frame)

NOTE: This breaker is 100% rated.

Io Setting	Ir Setting							
	1	0.98	0.95	0.93	0.90	0.88	0.85	0.8
0.9	NA	NA	NA	NA	NA	NA	NA	288
0.8	NA	NA	NA	297.6 ⁹	288	281.6	272	256
0.7	280	274.4	266	260.4	252	246.4	238	224
0.63	252	247	239.4	234.4	226.8	221.8	214.2	201.6
0.5	200	196	190	186	180	176	170	160
Long-time (LT) overload protection = $I_n \times I_o \times I_r$ - Example: $400 \times 0.5 \times 0.8 = 160$ A. See NEC-2008 Art. 240.6 (C) for additional information.								

8. The maximum available fault current was not evaluated by Underwriters Laboratories.

9. Factory default: $400 \times 0.93 \times 0.8 = 297.6$ A or ~ 300 A. The maximum Subfeed Output Loading must not be greater than 278 A/phase.

L-Frame with Micrologic 3.3 S Trip Unit (Subfeed Breaker)

NOTE: This breaker is 100% rated.

NOTE: The maximum subfeed output loading must not be greater than 278 A per phase.

In = 400 A		Value depending on sensor rating (In) and setting on rotary switch								
L Long time protection										
Pick-up (A) Tripping between 1.05 and 1.20 In	Ir =	125	150	175	200	225	250	300	N/A	N/A
S Short time protection										
Pick-up (A) accuracy ± 10%	Isd = Ir x...	1.5	2	3	4	5	6	7	8	10
I Instantaneous										
Pick-up (A) accuracy ± 15%	Ii = In x...	1.5	2	3	4	5	6	8	10	12

L-Frame with Micrologic 3.3 S Trip Unit (QB 600 V Canadian unit)

NOTE: This breaker is 100% rated.

In = 250 A		Value depending on sensor rating (In) and setting on rotary switch								
L Long time protection										
Pick-up (A) Tripping between 1.05 and 1.20 In	Ir =	70	80	100	125	150	175	200	225	250
S Short time protection										
Pick-up (A) accuracy ±10%	Isd = Ir x ...	1.5	2	3	4	5	6	7	8	10
I Instantaneous										
Pick-up (A) accuracy ±15%	Ii = In x ...	1.5	2	3	4	5	6	8	10	12

L-Frame Mission Critical with Micrologic 3.3 S-W 600 A Trip Unit

NOTE: This breaker is 80% rated.

In=600 A										
S short time protection										
Pick-up (A) accuracy ± 10%	Isd = Ir x...	1.5	2	3	4	5	6	7	8	10

I Instantaneous										
Pick-up (A) accuracy ± 15%	$I_i = I_n \times \dots$	1.5	2	3	4	5	6	8	10	11

L-Frame Mission Critical with Micrologic 3.3 S-W 400 A Trip Unit

NOTE: This breaker is 80% rated.

In=400 A										
S short time protection										
Pick-up (A) accuracy ± 10%	$I_{sd} = I_r \times \dots$	1.5	2	3	4	5	6	7	8	10
I Instantaneous										
Pick-up (A) accuracy ± 15%	$I_i = I_n \times \dots$	1.5	2	3	4	5	6	8	10	12

Recommended Current Rating of Supply OCPD

	208 V : 208 V	480 V : 208 V	600 V : 208 V	Maintenance bypass cabinet or PDU without transformer
	Standard rated ¹⁰			
Input (A)	500	225	175	450

Inrush Currents

The supply overcurrent protective device must be able to handle the below transformer inrush currents.

	208 V : 208 V	480 V : 208 V	600 V : 208 V
Inrush current (A)	4500	2000	1500

Recommended Conductor Sizes

⚠ DANGER

HAZARD OF ELECTRIC SHOCK, EXPLOSION OR ARC FLASH

The product must be installed according to the specifications and requirements as defined by Schneider Electric. It concerns in particular the external and internal protections (upstream circuit breakers, battery circuit breakers, cabling, etc.) and environmental requirements. No responsibility is assumed by Schneider Electric if these requirements are not respected.

Failure to follow these instructions will result in death or serious injury.

10. Standard circuit breakers are rated to carry 80% of their current rating continuously.

NOTE: All wiring must comply with all applicable national and/or local electrical codes. Maximum allowable conductor size: 2x350 kcmil.

Conductor sizing in this manual is based on Table 310-16 of the 2008 National Electrical Code (NEC) with the following assertions:

- 90°C conductors (THHN) for 75°C termination
- 3 Current Carrying Conductors
- An ambient temperature of 30°C

If the ambient room temperature is greater than 30°C, larger conductors are to be selected in accordance with the correction factors of the NEC.

Equipment Grounding Conductors (EGC) are sized in accordance with NEC Article 250-122 and Table 250-122.

Grounding Electrode Conductors (GEC) are sized in accordance with NEC Article 250-66 and Table 250-66.

The conductor sizes are recommendations for maximum configurations. Even if the load is less than the maximum rating, Schneider Electric recommends to plan for future load increases. If the system is operated at a lower load than its rating and it is desired to supply the system with a lower rated breaker and smaller conductors, conductor capacities are to be selected in accordance with the NEC. The transformer inrush must be taken into account when sizing conductors.

		208 V : 208 V	480 V : 208 V	600 V : 208 V	Maintenance bypass cabinet or PDU without transformer ¹¹
Input (phase and neutral)	Copper	(2) ¹² 4/0	4/0	2/0	(2) 4/0
	Aluminum	(2) ¹² 300 kcmil	300 kcmil	4/0	(2) 300 kcmil
Grounding Electrode Conductor (GEC)	Copper	2 AWG			NA
	Aluminum	1/0			NA
Equipment Grounding Conductor (EGC)	Copper	2 AWG	4 AWG	6 AWG	2 AWG
	Aluminum	1/0	2 AWG	4 AWG	1/0
Output	Supplied with power distribution modules except for maintenance bypass				
Subfeed output	Copper	(2) 2/0 Phase and Neutral, 4 AWG EGC, GEC not required ¹³			
	Aluminum	(2) 4/0 Phase and Neutral, 2 AWG EGC, GEC not required ¹³			

Batteries

Battery Input	
Nom. voltage (VDC)	2 x 192
Connection	BAT+, CT, BAT-
Nom. battery discharge ¹⁴ (A)	276

11. The PDU without a transformer requires a neutral and does not require GEC.

12. Two conductors per phase and neutral (when neutral is required)

13. Subfeed is required to have two conductors per phase and neutral for full output due to limited wire bend space.

14. Based on rated load and nominal battery voltage (2.0 V/cell)

Battery Input	
Max. battery discharge ¹⁵ (A)	344
End of discharge voltage	1.6-1.75 V/cell (automatic, depending on load)
Ah rating	Unlimited
Nom. output charge current (A)	52

Heat Dissipation

	Without PDU	With PDU			
	208 V	208 V: 208 V	480 V: 208 V	600 V: 208 V	208 V no transformer
Heat dissipation at 100% load and charging batteries (BTU/hr)	22,687	34,572	34,231	32,525	28,771

15. Based on rated load at the end of the discharge (1.6 V/cell)

Mechanical Assembly

Rearrange the Side Panels

⚠ DANGER

HAZARD OF ELECTRIC SHOCK, EXPLOSION, OR ARC FLASH

The UPS side panels must always be installed on the right side of the PDU even though it is placed up against the UPS.

Failure to follow these instructions will result in death or serious injury.

NOTE: The type of installation determines the need to re-arrange the side panels. The side panels are installed on the UPS and should be moved to the end of row cabinets.

Remove the Side Panels

⚠ DANGER

HAZARD OF ELECTRIC SHOCK, EXPLOSION, OR ARC FLASH

- The side panels must be locked with the red key to avoid unintended access to live parts.
- Ensure that all bonding clips are in place on the lower edge on the side panel.

Failure to follow these instructions will result in death or serious injury.

1. Unlock the side panels with the red key (provided).
2. Press down on the lock and then pull out and up.

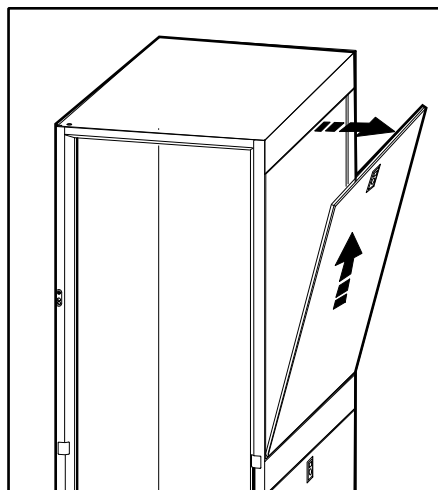

Install the Side Panels

1. Set the base of the panel at an angle and push the panel in.

2. Lock the side panels with the red key.

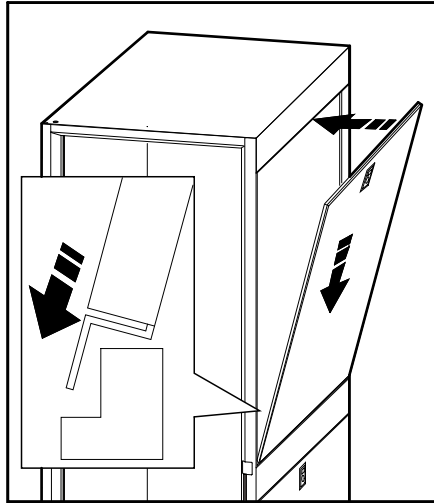

Install the Internal Conductors for Bottom Entry Systems in Installations with PDU without Transformer

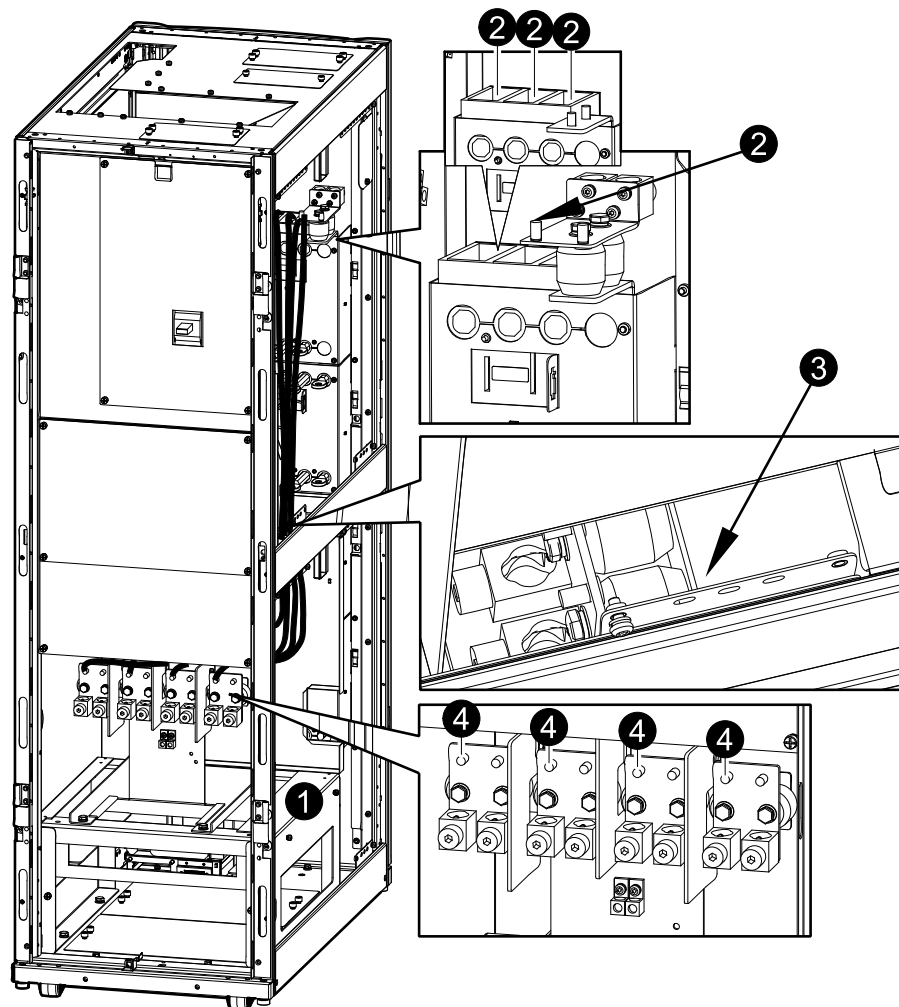

1. Remove the sidepanel from the PDU.
2. Connect the N, L1, L2, L3 conductors (supplied in the bottom of the cabinet) to the input terminals.
3. Route the cables to the bottom terminal, through the hole in the right side.

4. Connect the N, L1, L2, L3 conductors to the bottom terminals.

Perform Equipotential Bonding

NOTE: It might be necessary to move some of the equipotential bonding wires to fit your system configuration.

Rear view of the System

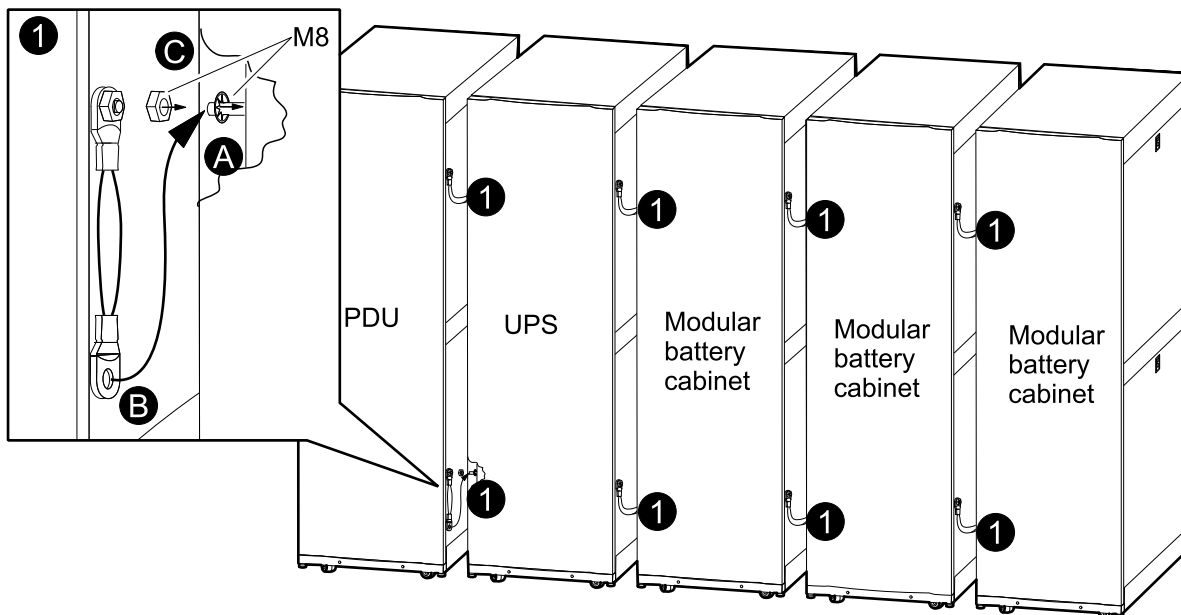

1. Connect the two equipotential bonding conductors between adjacent cabinets in the system. The bonding conductors are pre-connected to the PDU, sidecar, maintenance bypass cabinet, and all the modular battery cabinets. The M8 nuts and washers are supplied in the accessory kit.

Interconnect and Level the Cabinets

⚠ CAUTION
TIP HAZARD
The system must be installed on a level floor. The leveling feet will stabilize the cabinet, but will not account for a badly sloped floor.
Failure to follow these instructions can result in injury or equipment damage.

1. Align the cabinets.

2. Turn the joining brackets right and secure with screw to interconnect the cabinets.

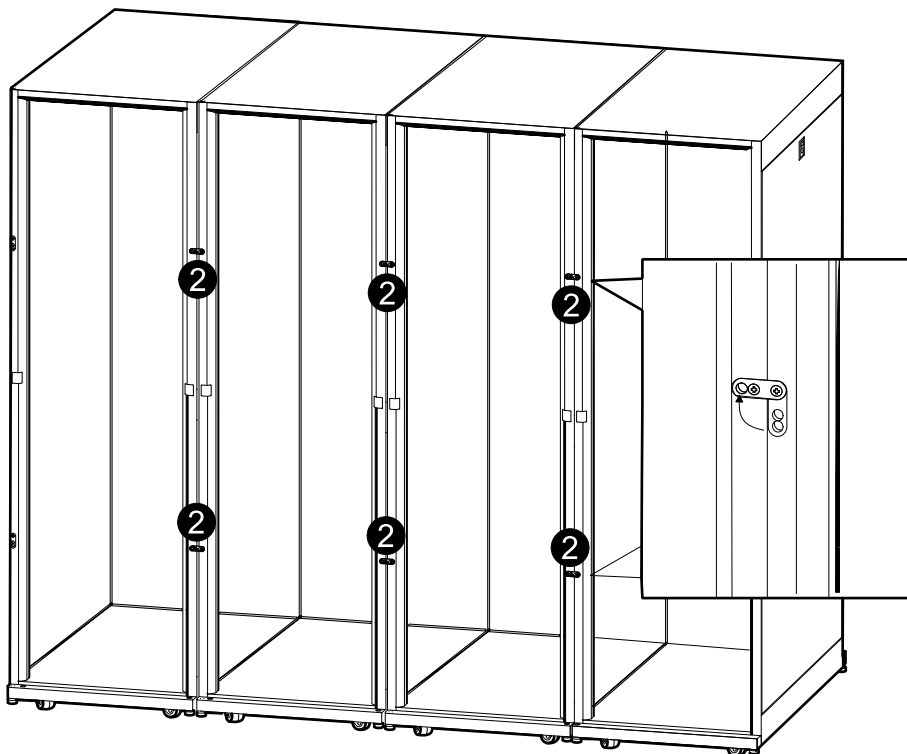

3. Use a screwdriver to lower the four leveling feet.

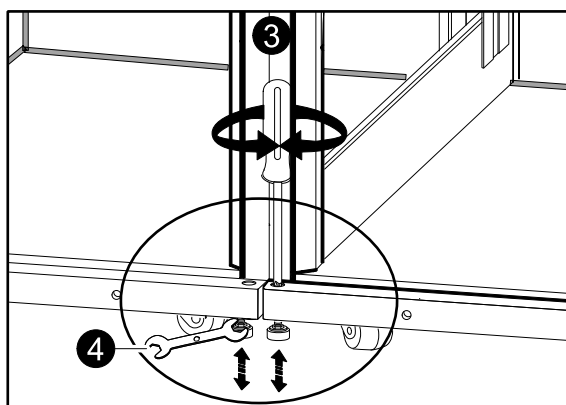

4. Use a 13/17 mm wrench to adjust the leveling feet.

▲ CAUTION

TIP HAZARD

Do not move the cabinet after the leveling feet have been lowered.

Failure to follow these instructions can result in injury or equipment damage.

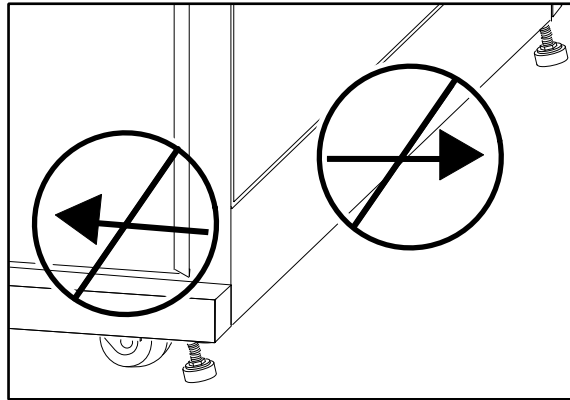

Connect Power Conductors and Communication Cables

The connection of power conductors and communication cables varies depending on configuration. Therefore this section is divided in three parts. Use the procedure specific to your configuration:

- *Procedure for System without PDU, page 25*
- *Procedure for Systems with PDU without Transformer, page 41*
- *Procedure for Systems with PDU with Transformer, page 60*

Procedure for System without PDU

System Overview

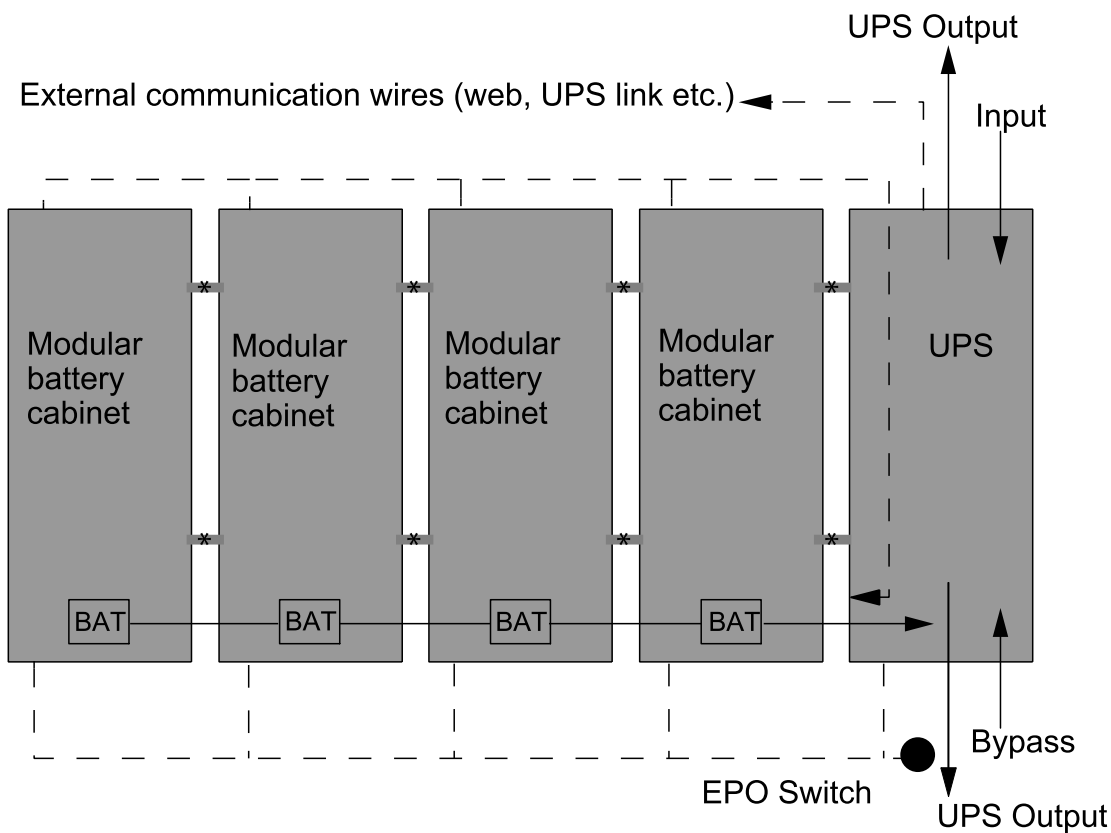

Prepare for Cables – Systems without PDU

1. Open the rear door of the UPS.
2. Remove all four covers, starting from the top, by loosening the two screws in each cover. Note the orientation of the covers.

3. Lift the cover up and out.

Rear view of the UPS

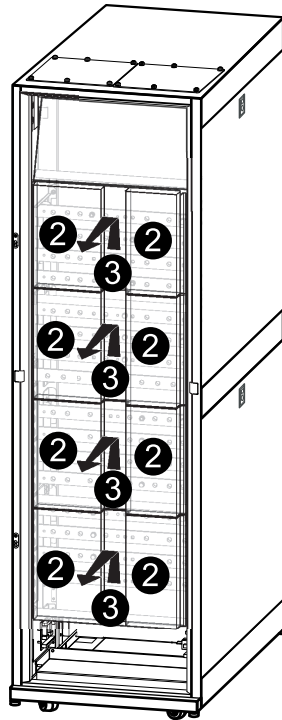

Make Holes in the Top of the UPS

⚠ DANGER

HAZARD OF ELECTRIC SHOCK, EXPLOSION, OR ARC FLASH

Do not drill or cut holes for cables or conduits with the covers installed and do not drill in close proximity to the UPS.

Failure to follow these instructions will result in death or serious injury.

1. Remove the cover plates.

Rear view of the UPS

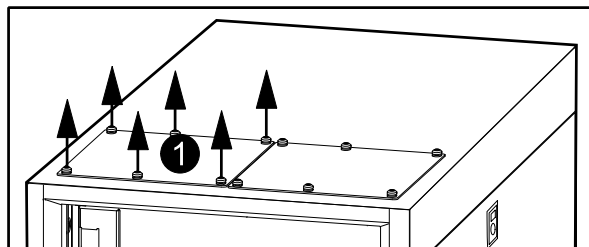

2. Drill as many holes as necessary in the solid plate and install the conduits.
Reinstall the plate with the conduits installed.

Rear view of the UPS

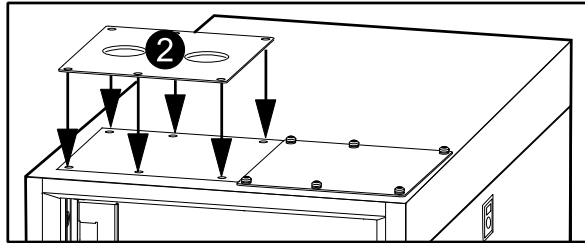

Make Holes in the Bottom of the UPS

⚠ DANGER

HAZARD OF ELECTRIC SHOCK, EXPLOSION, OR ARC FLASH

Do not drill or cut holes for cables or conduits with the covers installed and do not drill in close proximity to the UPS.

Failure to follow these instructions will result in death or serious injury.

1. Disconnect the grounding cable.
2. Remove the screws in front of the bottom plate.
3. Lift the plate to remove it.
4. Drill holes in the plate and install the conduits.

Rear view of the UPS

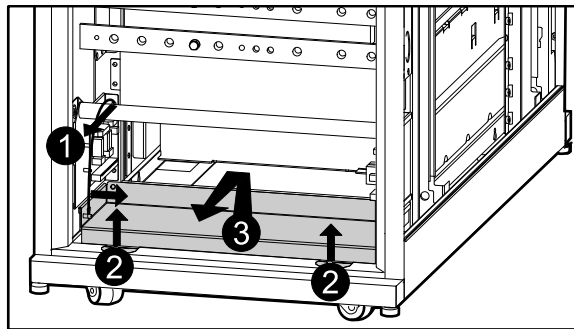

5. Reinstall the plate with the conduits installed.
6. Reinstall the screws in front of the plate.
7. Reconnect the grounding cable. The required torque value is 8 Nm (5.9 lb-ft).

Rear view of the UPS

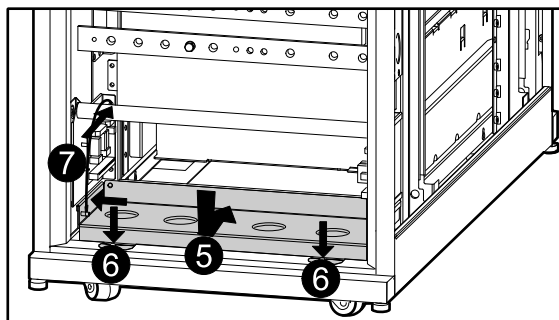

Connect Power Conductors – Systems without PDU

⚠ CAUTION

HAZARD OF EXCESSIVE TERMINAL TEMPERATURE

Ensure clockwise phase rotation and neutral location. The power terminal bolt diameter is 10 mm. The required torque value is 26 Nm (19.18 lb-ft).

Failure to follow these instructions can result in injury or equipment damage.

1. Route the conductors through top or bottom of the cabinet.
2. In single utility systems, connect the three cables (0W3617) included with the unit. Connect bypass L3 to input L3, bypass L2 to input L2 and bypass L1 to input L1.
3. Connect the input conductors to the input busbars (L1, L2, L3, N).
4. Connect the output conductors to the output busbars (L1, L2, L3, N).
5. In dual utility systems, connect the bypass conductors to the bypass busbars (L1, L2, L3).

6. Connect the PE cable in the UPS according to the symbol on the grounding rail.

Rear view of the UPS

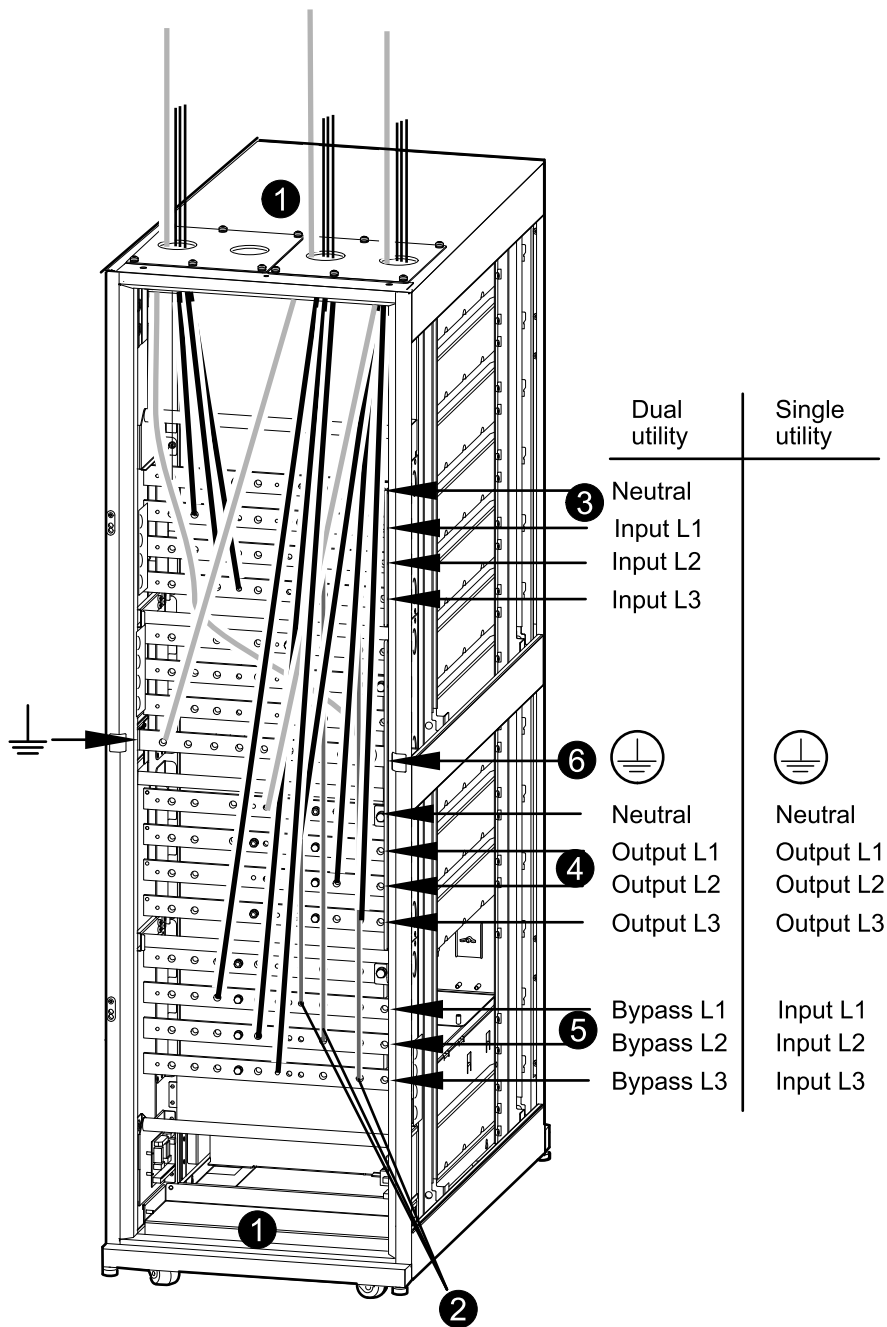

Connect Maintenance Bypass Cabinet (Option)

Remove the Breaker Cover Panel from the Maintenance Bypass Cabinet

1. Remove the front panel by pushing the two latches in the top of the panel.
2. Remove the breaker cover panel by removing the four mounting screws.
3. Perform equipotential bonding and interconnect and level the maintenance bypass cabinet with the other cabinets – see *Perform Equipotential Bonding*, page 22 and *Interconnect and Level the Cabinets*, page 22 on how to do this.

Maintenance Bypass Field Wiring Specification

Input wiring		
Ambient temperature	Max. input current	Wire size
30°C	332 A	2 x 4/0
40°C	332 A	2 x 300 Kcmil

Output wiring		
Ambient temperature	Max. input current	Wire size
30°C	278 A	2 x 4/0
40°C	278 A	2 x 250 Kcmil

Front view of the maintenance bypass cabinet

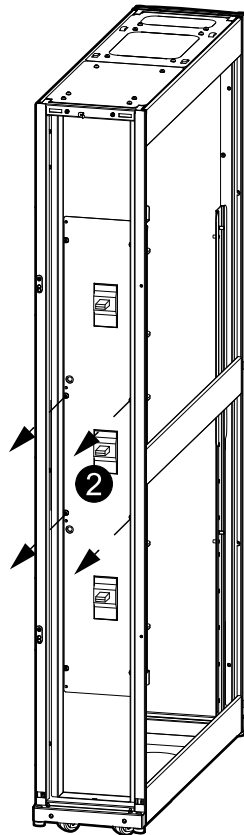

Prepare the Maintenance Bypass Cabinet for Cables in Bottom Entry Systems

⚠ CAUTION

HAZARD OF EQUIPMENT DAMAGE

Ensure sharp edges from drilling are properly covered to prevent damaging cable insulation.

Failure to follow these instructions can result in injury or equipment damage.

⚠ CAUTION

HAZARD OF EQUIPMENT DAMAGE

Remove the cover plates from the cabinet. Drilling or cutting of plates must not take place over the top or inside the cabinet or while parts are installed in the cabinet.

Failure to follow these instructions can result in injury or equipment damage.

1. Remove the dedicated bottom cover plate for power cables.

Front view of the maintenance bypass cabinet

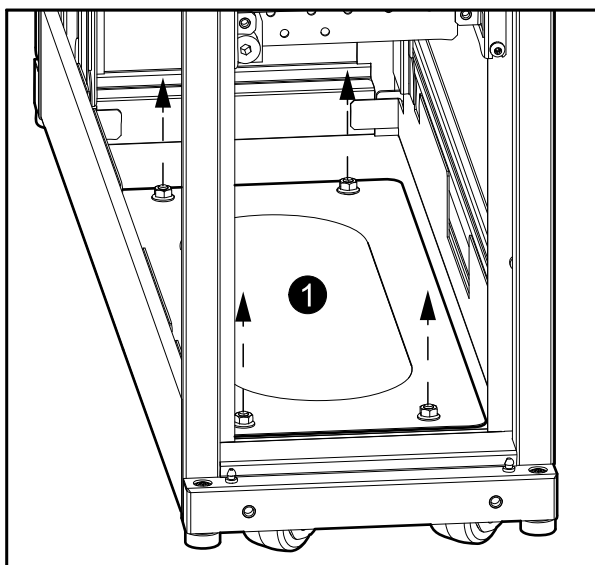

2. Drill holes as needed in the plate for conduits and reinstall the plate with the conduits installed.

Front view of the maintenance bypass cabinet

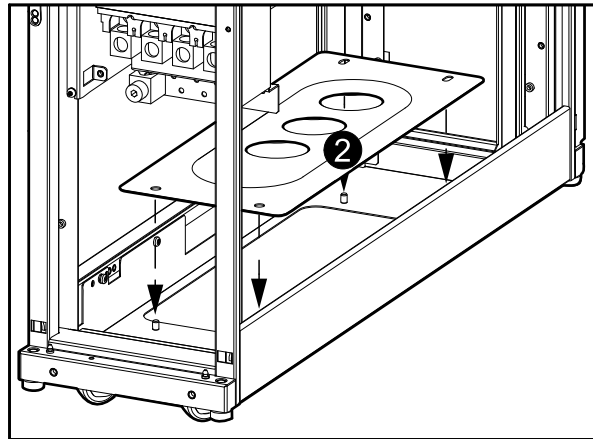

Prepare the Maintenance Bypass Cabinet for Cables in Top Cable Entry Systems

⚠ CAUTION

HAZARD OF EQUIPMENT DAMAGE

Ensure sharp edges from drilling are properly covered to prevent damaging cable insulation.

Failure to follow these instructions can result in injury or equipment damage.

⚠ CAUTION

HAZARD OF EQUIPMENT DAMAGE

Remove the cover plates from the cabinet. Drilling or cutting of plates must not take place over the top or inside the cabinet or while parts are installed in the cabinet.

Failure to follow these instructions can result in injury or equipment damage.

1. Remove the dedicated top cover plate for power cables.

Front view of the maintenance bypass cabinet

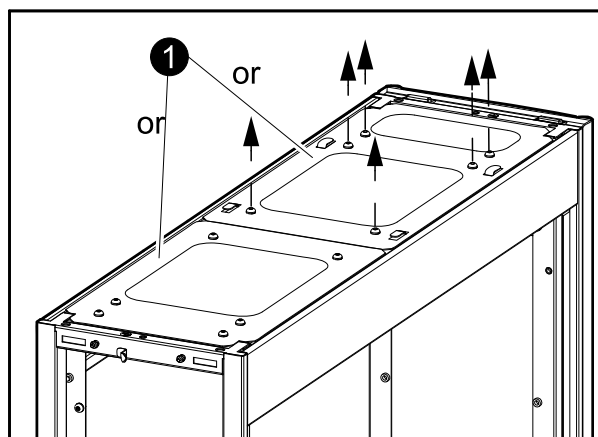

2. Drill holes as needed in the plate for conduits and reinstall the plate with the conduits installed.

Front view of the maintenance bypass cabinet

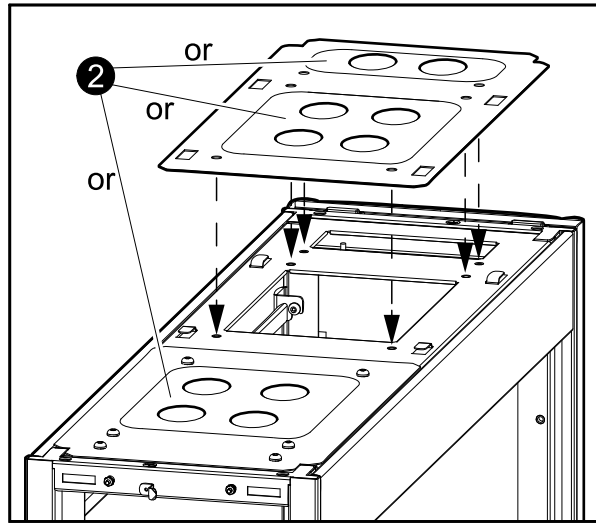

Connect Power Conductors Between the UPS and the Maintenance Bypass Cabinet

⚠ CAUTION

HAZARD OF EQUIPMENT DAMAGE

Ensure sharp edges from drilling are properly covered to prevent damaging cable insulation.

Failure to follow these instructions can result in injury or equipment damage.

NOTE: The connection can be done from the left or right side of the maintenance bypass cabinet.

1. Untie/cut the zip ties to uncoil the cables.
2. Route the output and bypass/input conductors through the side of the maintenance bypass cabinet and through the cable relief in the UPS.
3. Connect L1, L2 and L3 from maintenance bypass cabinet Q1 bottom and N from maintenance bypass cabinet Q3 top to the UPS bypass input.
4. Connect L1, L2, L3 and N from maintenance bypass cabinet Q2 top to the UPS output.
5. Route the signal cable through the side of the maintenance bypass cabinet and into the UPS.
6. Remove the jumper wire harness between J1 and J2 on the maintenance bypass interface board (0P3199) in the UPS. See an illustration of the maintenance bypass interface board here: *Maintenance Bypass Interface Board*, page 40 for reference.

- Connect the signal cable to J1 and J8 on the maintenance interface board (0P3199) in the UPS.

NOTE: Leave the jumper pin between J2 pins 13 and 14.

NOTE: Explanation: For third party switchgear without surveillance, remove the jumper pin between J2 pins 13 and 14. For wallmounted switchgear with surveillance interconnected to the maintenance bypass interface board, leave the jumper pin installed between J2 pins 13 and 14.

Right side view of the maintenance bypass cabinet

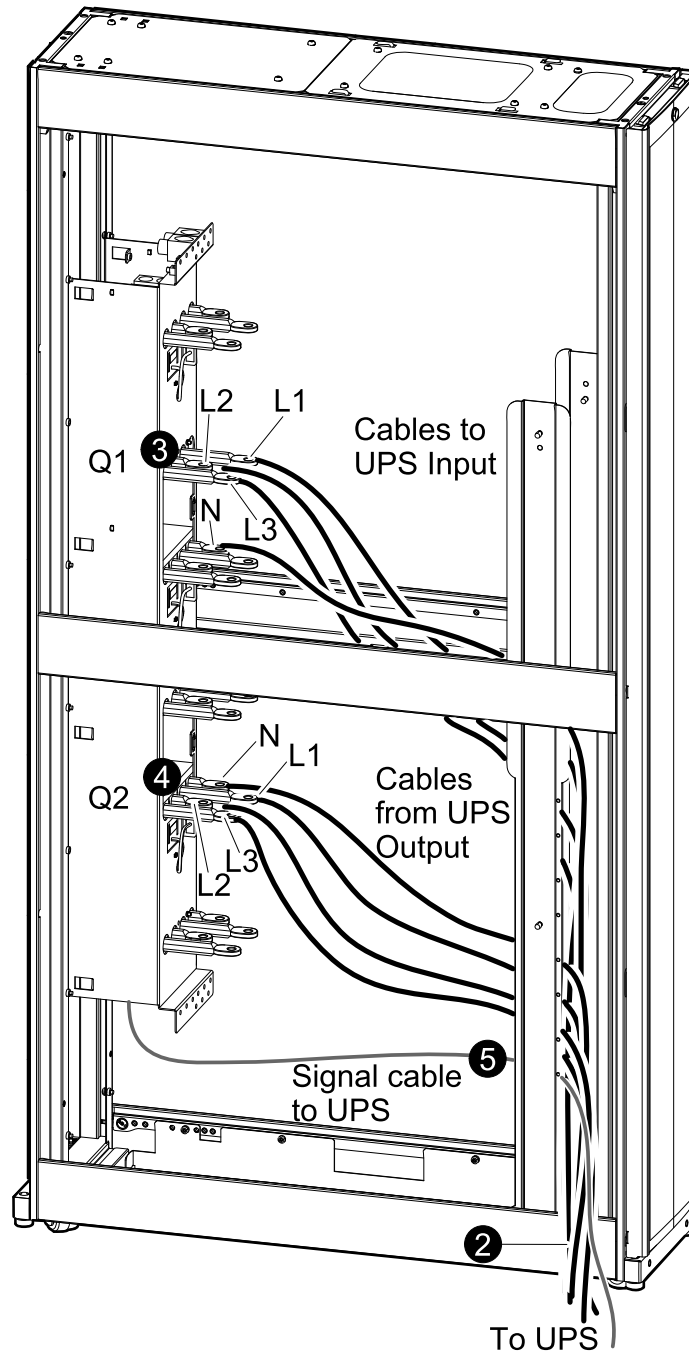

NOTE: Factory-installed conductors are not shown on the image.

Connect Input and Output Power Conductors to the Maintenance Bypass Cabinet

⚠ CAUTION

HAZARD OF EXCESSIVE TERMINAL TEMPERATURE

Ensure clockwise phase rotation. The required torque value for the dual-lug breaker input connector is 31 Nm (22.86 lb-ft). Use the long set screws for the input cable range of AWG 2 minimum to 4/0 maximum. Use the short set screws, supplied with maintenance bypass cabinet, for the input cable range of 250 kcmil minimum to 500 kcmil maximum. Ensure that the plastic cover is installed over the breaker terminals.

Failure to follow these instructions can result in injury or equipment damage.

1. Route the input conductors through the top or bottom of the maintenance bypass cabinet to the Q1 input. Remove the plastic cover from the top breaker terminals.
2. Connect the input conductors to the L1, L2, L3, N, EGC (Equipment Grounding Conductor) terminals. Install the plastic cover on the top breaker terminals.
3. Route the output conductors through the top or bottom of the maintenance bypass cabinet to the Q2 output. Remove the plastic cover from the bottom breaker terminals.

4. Connect the output conductors to the L1, L2, L3, N, EGC terminals. Install the plastic cover on the bottom breaker terminals.

Front view of the maintenance bypass cabinet

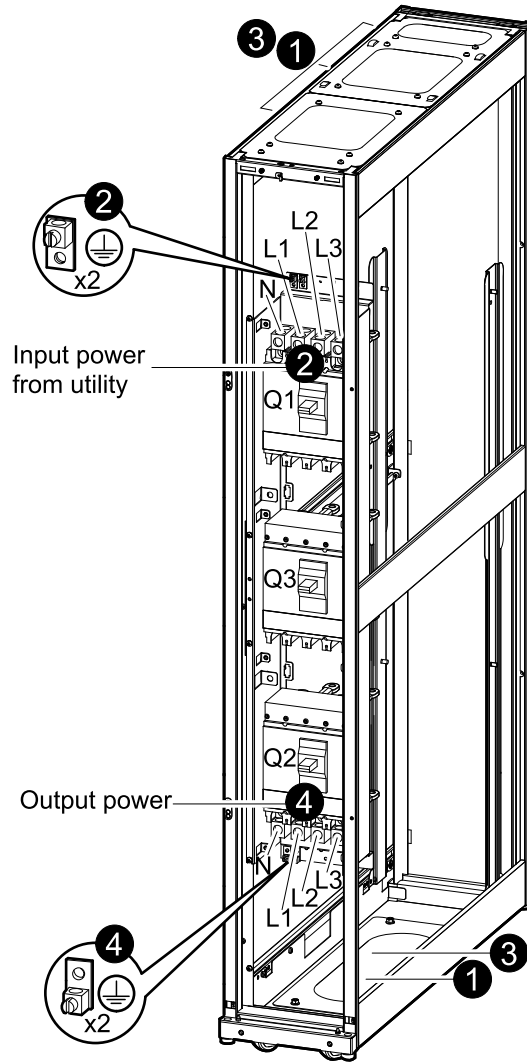

Connect Input and Output Power Conductors from the 150 kVA InfraStruxure PDU (Option) to the Maintenance Bypass Cabinet

⚠ CAUTION

HAZARD OF EXCESSIVE TERMINAL TEMPERATURE

Ensure clockwise phase rotation. The required torque value for the dual-lug breaker input connector is 31 Nm (22.86 lb-ft). Use the long set screws for the input cable range of AWG 2 minimum to 4/0 maximum. Use the short set screws, supplied with the maintenance bypass cabinet, for the input cable range of 250 kcmil minimum to 500 kcmil maximum. Ensure that the plastic cover is installed over the breaker terminals.

Failure to follow these instructions can result in injury or equipment damage.

1. Route the transformer output conductors from the chase nipple in the PDU, through the upper open side on the maintenance bypass cabinet to the Q1 input. Remove the plastic cover from the top breaker terminals.
2. Connect the input conductors to the L1, L2, L3, N, EGC (Equipment Grounding Conductor) terminals. Install the plastic cover on the top breaker terminals.
3. Route the PDU distribution busbar conductors from the chase nipple in PDU, through the upper open side on the maintenance bypass cabinet to the Q2 output. Remove the plastic cover from the bottom breaker terminals.

4. Connect the output conductors to the L1, L2, L3, N, EGC terminals. Install the plastic cover on the bottom breaker terminals.

Front view of the maintenance bypass cabinet

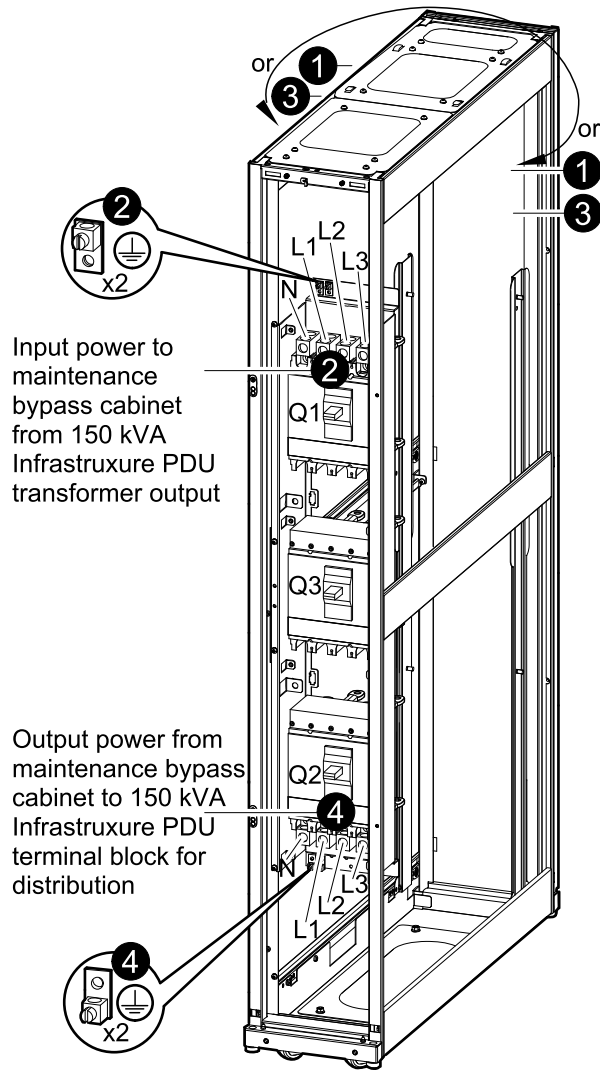

Connect Communication Wires – Systems without PDU

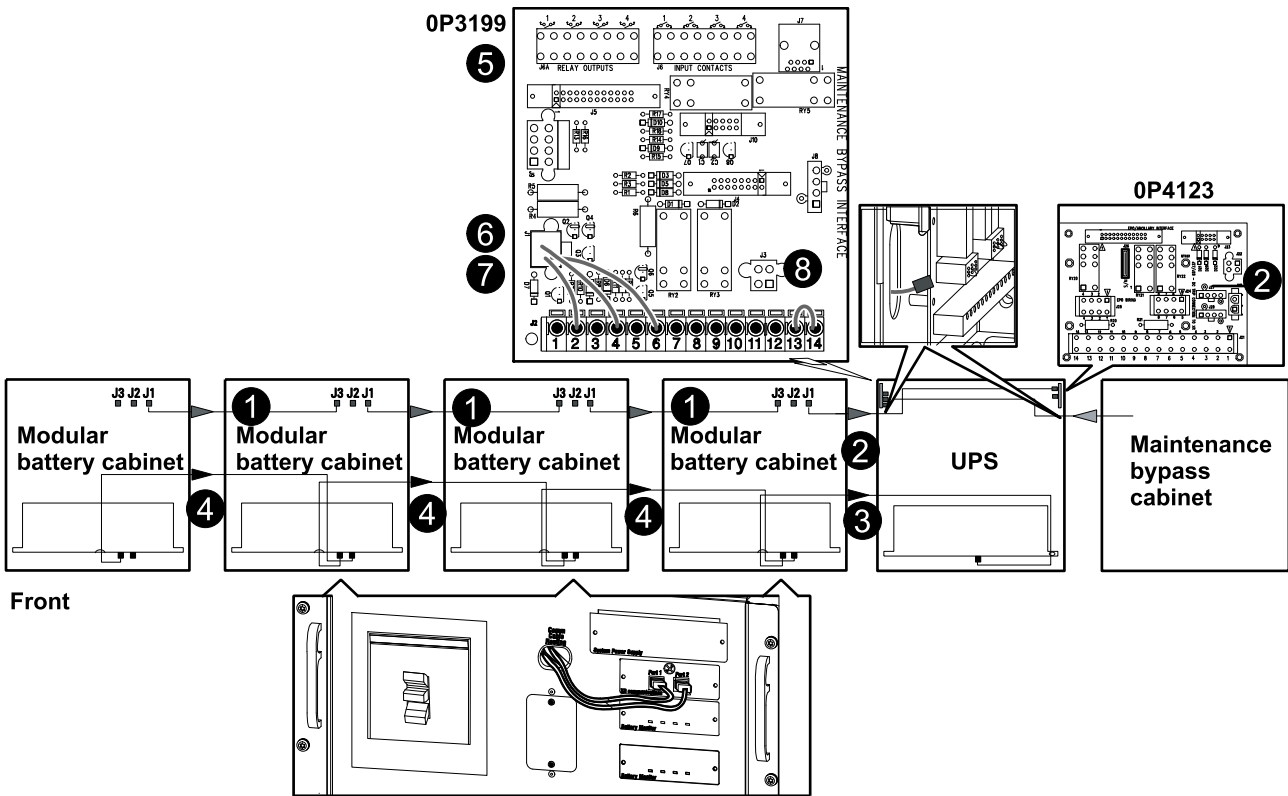

1. Route the battery breaker trip cable from J1 in the first modular battery cabinet to J3 in the next modular battery cabinet. Repeat the procedure for all modular battery cabinets.
2. Route the battery breaker trip cable from J1 in the last modular battery cabinet to J27 on the EPO/ancillary interface board (0P4123) in the UPS (for remote modular battery cabinet the length of the cable must not exceed 50 m).
3. Route the communication cable from the UPS XR Communications port 1 to port 2 in the first modular battery cabinet nearest the UPS in the row (for remote modular battery cabinets, the length of the communications cable from the UPS must not exceed 50 m).
4. Route the communication cable from XR Communications port 1 in each modular battery cabinet to port 2 in the next modular battery cabinet. Remove the terminator when necessary.
5. Route the communication cables from the maintenance bypass cabinet to the maintenance bypass interface board (0P3199) in the UPS. Refer to the wiring diagram on the next page for connection information.
6. In installations with external switchgear, remove jumper wire harness between J1 and J2.
7. In installations without any switchgear, install jumper wire harness between J1 and J2.
8. Remove the jumper between pins 13 and 14 in J2 in installations without external switchgear/PDU.

NOTE: For third party switchgear without surveillance, remove the jumper pin between J2 pins 13 and 14. For wallmounted switchgear with surveillance interconnected to the maintenance bypass interface board, leave the jumper pin installed between J2 pins 13 and 14.

Maintenance Bypass Interface Board

⚠ DANGER

HAZARD OF ELECTRIC SHOCK, EXPLOSION OR ARC FLASH

Ensure that the wires are properly retained and kept away from high-voltage lines and breakers.

Failure to follow these instructions will result in death or serious injury.

Make contact closure connections (N/O or N/C) to monitor dry contacts. Up to eight connections can be made - four input contacts and four output relays.

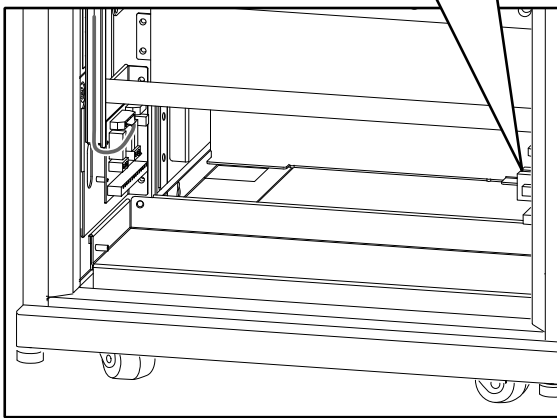
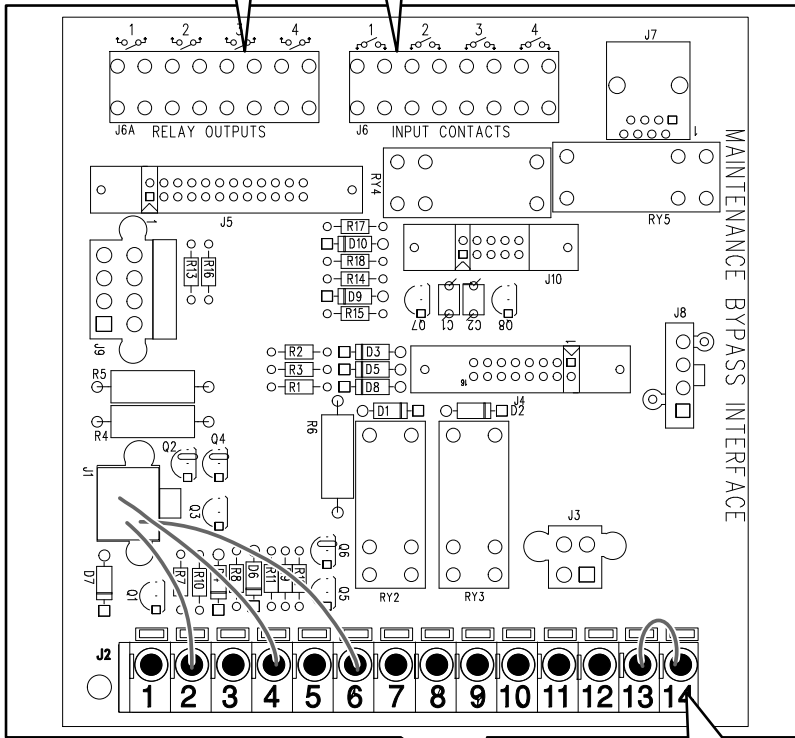

Output relays:

240 V / 8 A 0.3 VA / 1.9 kW

Input signals: Contact load: TTL

- 1/2 Q001 UPS input switch (N/O position)
- 3/4 Q002 UPS output switch (N/O position)
- 5/6 Q003 UPS service bypass switch (N/C position)
- 7/8 OK to operate UPS output switch Q002
- 9/10 OK to operate service bypass switch Q003
- 11/12 Not used
- 13/14 External switchgear present

NOTE: For third party switchgear without surveillance, remove the jumper pin between J2 pins 13 and 14. For wallmounted switchgear with surveillance interconnected to the maintenance bypass interface board, leave the jumper pin installed between J2 pins 13 and 14.

Procedure for Systems with PDU without Transformer

Overview of Single Utility System with Top Cable Entry

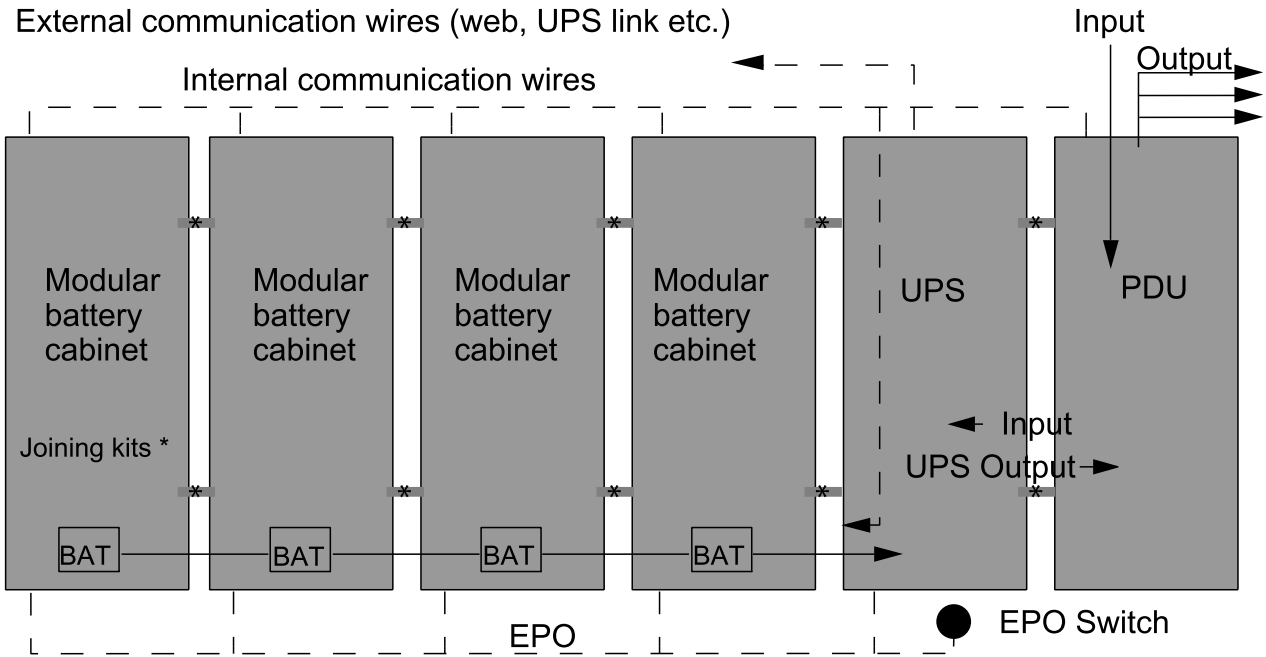

Overview of Single Utility System with Bottom Cable Entry

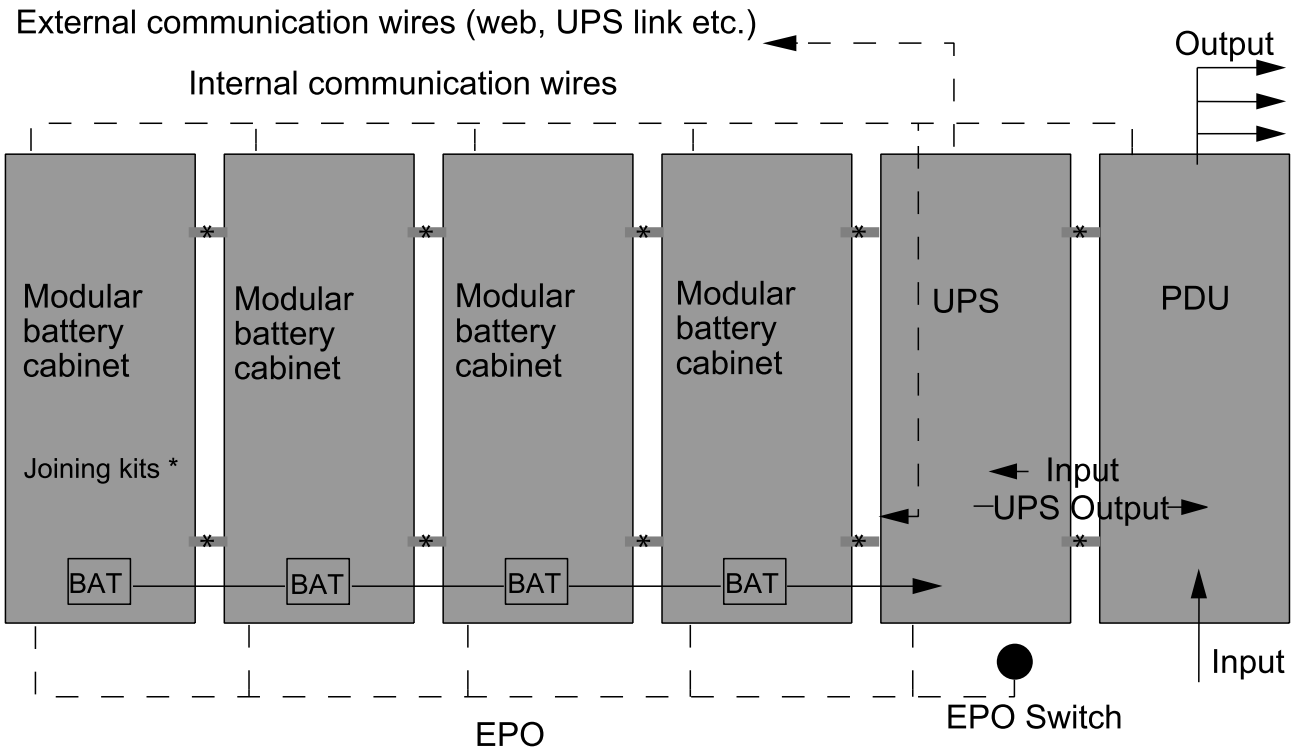

Overview of Dual Utility System with Top Cable Entry

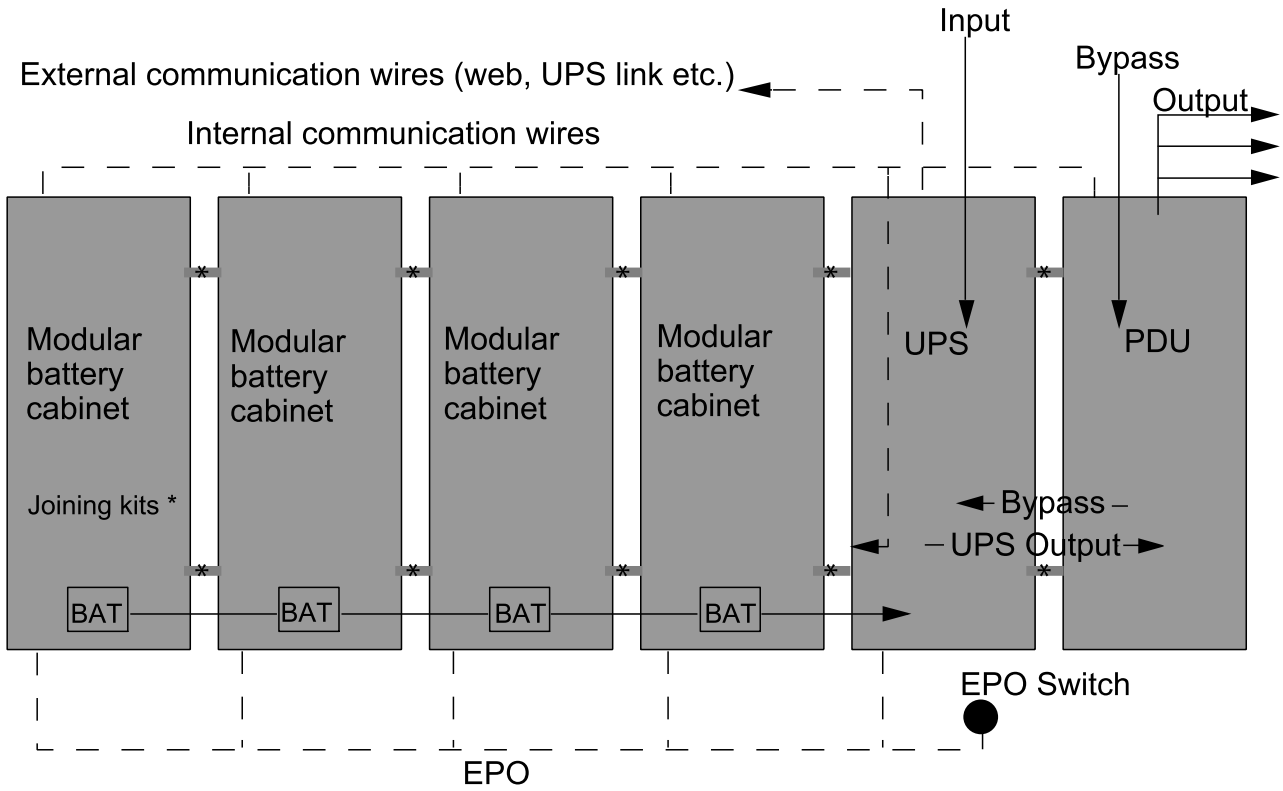

Overview of Dual Utility System with Bottom Cable Entry

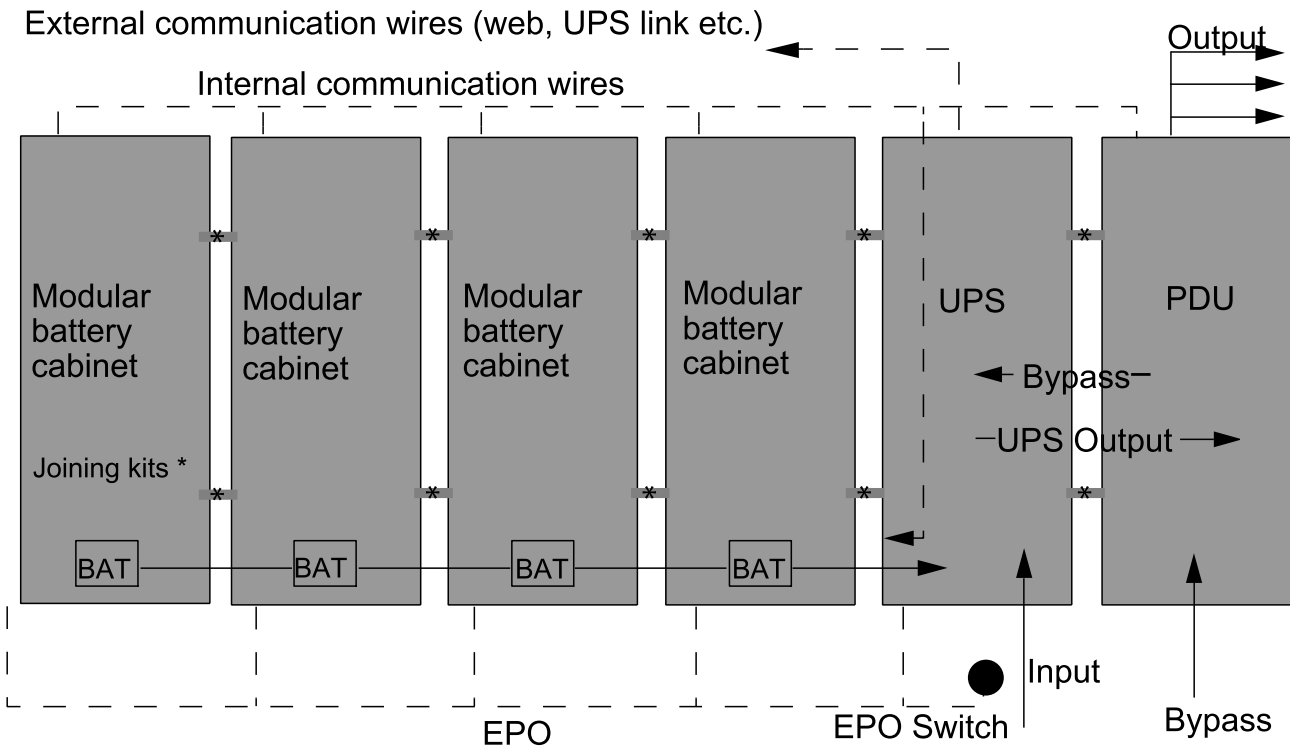

Prepare for Cables – Systems with PDU without Transformer

⚠ DANGER

HAZARD OF ELECTRIC SHOCK, EXPLOSION, OR ARC FLASH

Do not drill or cut holes for cables or conduits with the covers installed and do not drill in close proximity to the UPS.

Failure to follow these instructions will result in death or serious injury.

1. Open the rear door of the UPS.
2. Remove all four covers, starting from the top, by loosening the two screws in each cover. Note the orientation of the covers.
3. Lift the cover up and out.

Rear view of the UPS

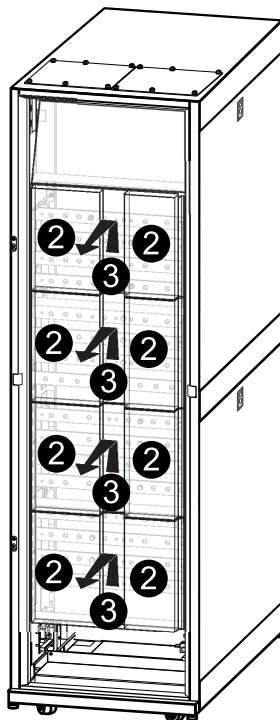

The following steps are only applicable to systems with the PDU placed to the left of the UPS (front view):

4. Remove the two top cable reliefs from the left side and save for step 7.
5. Remove the bottom cable relief from the right side and save for step 8.
6. Remove the neutral busbar from the right side (rear view) of the UPS by loosening the four bolts, and mount the busbar on the left side of the UPS.
7. Mount the cable reliefs from step 4 on the right side (rear view).

8. Mount the cable relief from step 5 on the left side (rear view).

Rear view of the UPS

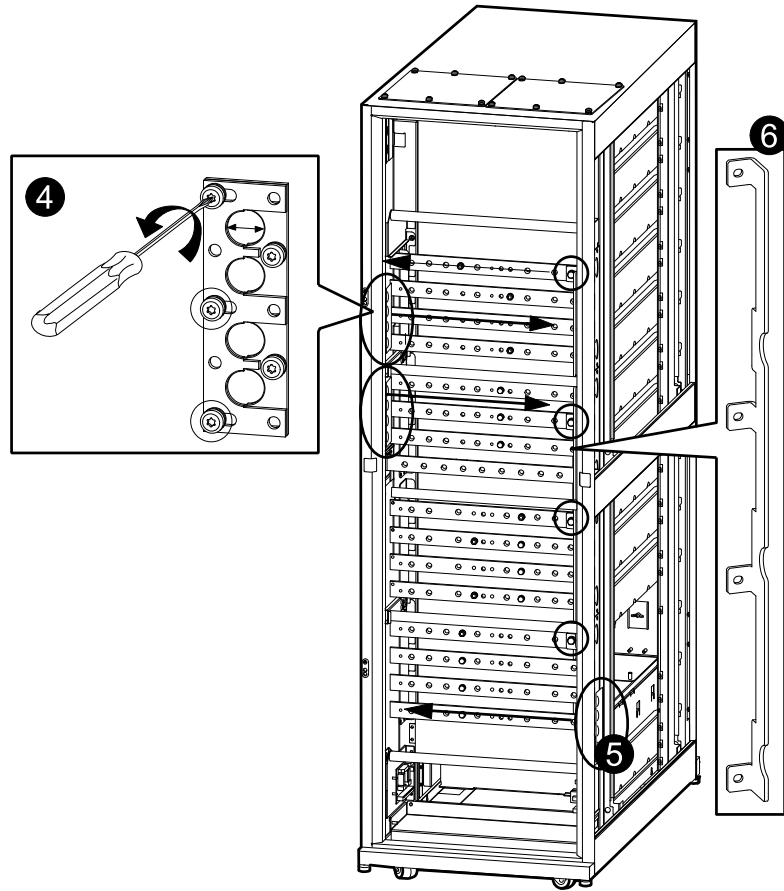

9. For top entry systems, remove the bottom cover on the rear side of the PDU and throw away or recycle the coil of conductors.

Rear view of the PDU

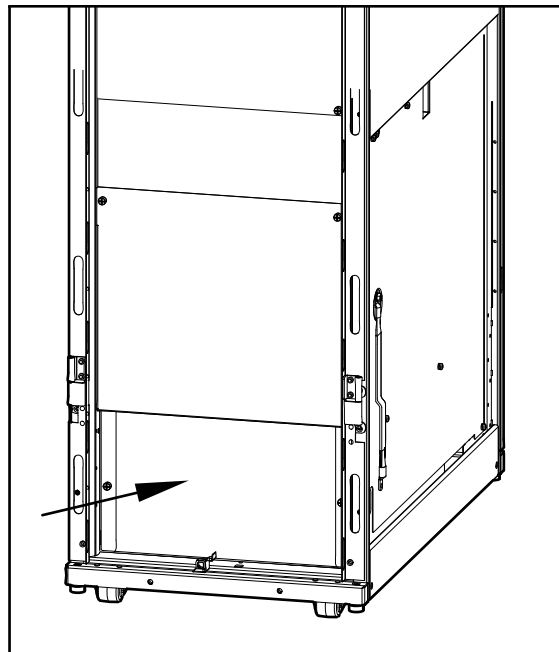

10. Open the front door of the PDU.

11. Remove the upper cover. Use a Phillips screwdriver to remove the captive panel fasteners.

Front view of the PDU

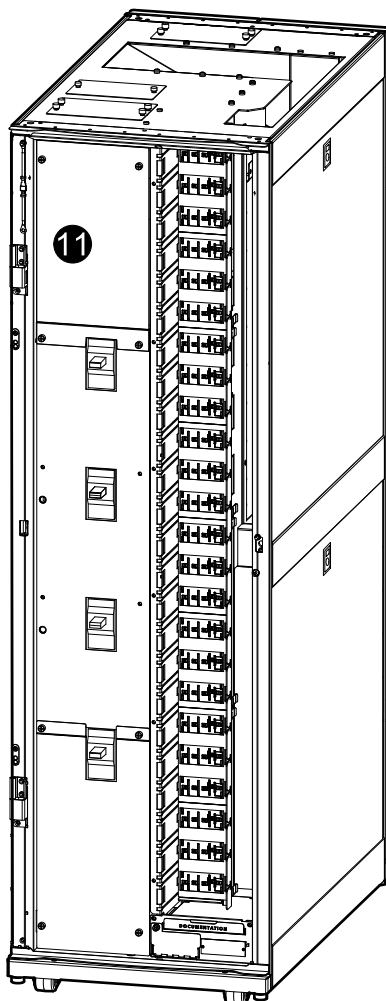

Make Holes in the Top Cover of the PDU

⚠ DANGER

HAZARD OF ELECTRIC SHOCK, EXPLOSION, OR ARC FLASH

Do not drill or cut holes for cables or conduits with the covers installed and do not drill in close proximity to the UPS.

Failure to follow these instructions will result in death or serious injury.

1. Remove the dedicated cover plate for power cables.

Front view of the PDU

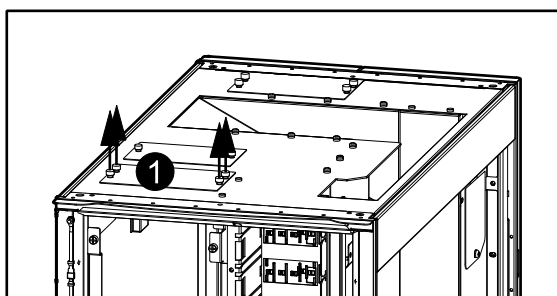

2. Drill holes in the plate for conduits. Reinstall the plate with the conduits installed.

Front view of the PDU

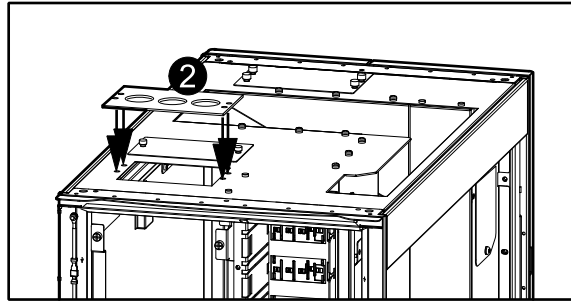

3. Remove the dedicated cover plate for subfeed breaker cables.

Rear view of the PDU

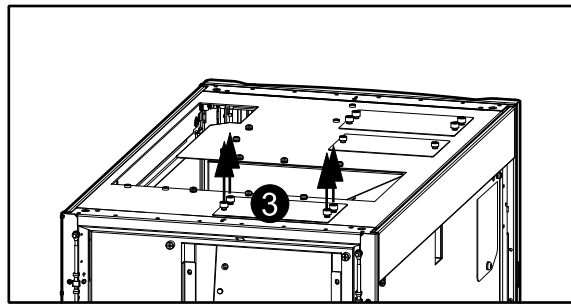

4. Drill holes in the plate for conduits and reinstall the plate with the conduits installed.

Rear view of the PDU

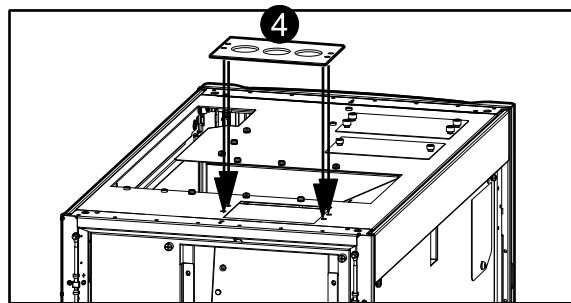

Make Holes in the Bottom and Top of the PDU

⚠ DANGER

HAZARD OF ELECTRIC SHOCK, EXPLOSION, OR ARC FLASH

Do not drill or cut holes for cables or conduits with the covers installed and do not drill in close proximity to the UPS.

Failure to follow these instructions will result in death or serious injury.

NOTE: The subfeed breaker cables only allow top entry cable routing in the PDU cabinet.

1. Remove the bottom two plates on the rear side of the PDU.

Rear view of the PDU

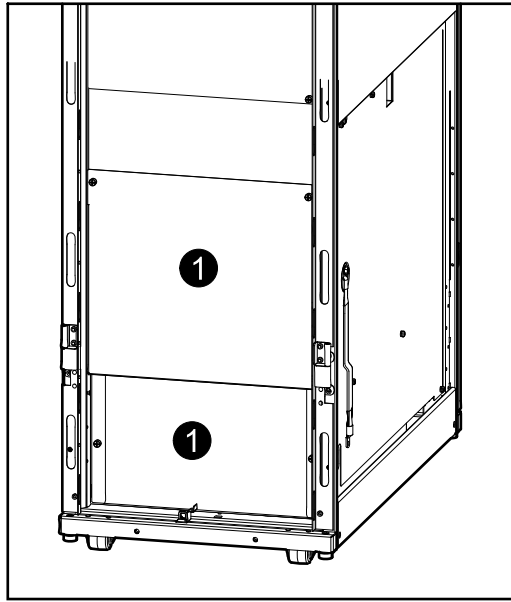

2. Remove the dedicated cover plate for power cables.

Rear view of the PDU

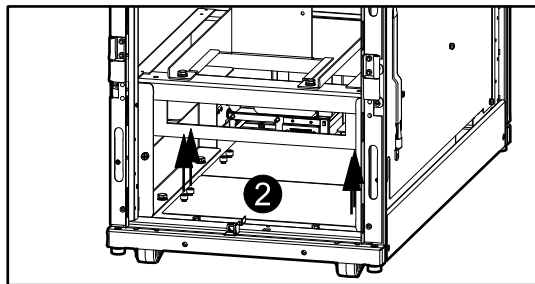

3. Drill holes in the plate for conduits and reinstall the plate with the conduits installed.

Rear view of the PDU

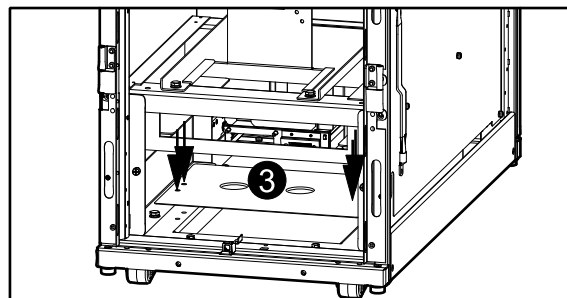

- Remove the dedicated cover plate for subfeed breaker cables.

Rear view of the PDU

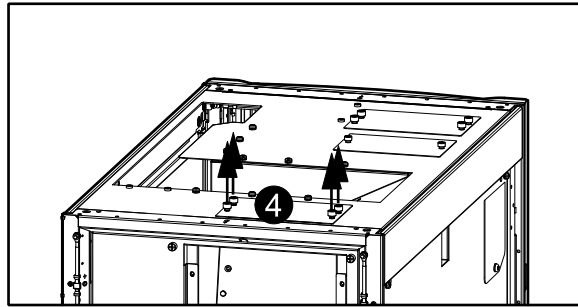

- Drill holes in the plate for conduits. Reinstall the plate with the conduits installed.

Rear view of the PDU

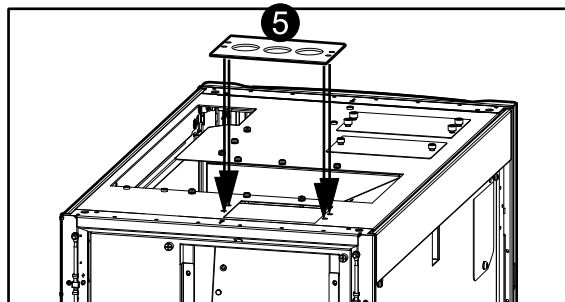

Connect Power Conductors – Systems with PDU without Transformer — Top Cable Entry

⚠ CAUTION

HAZARD OF EXCESSIVE TERMINAL TEMPERATURE

Ensure clockwise phase rotation and neutral location of the power terminal bolt. The required torque values are: 62 Nm (45.73 lb-ft) for the Neutral, 31 Nm (22.86 lb-ft) for the 3 phases in the NSJ breaker, 50 Nm (36.88 lb-ft) for the 3 phases in the L-frame and L-frame Mission Critical breaker, 5.6 Nm (4.13 lb-ft) for the EGC.

Failure to follow these instructions can result in injury or equipment damage.

Front view of the PDU

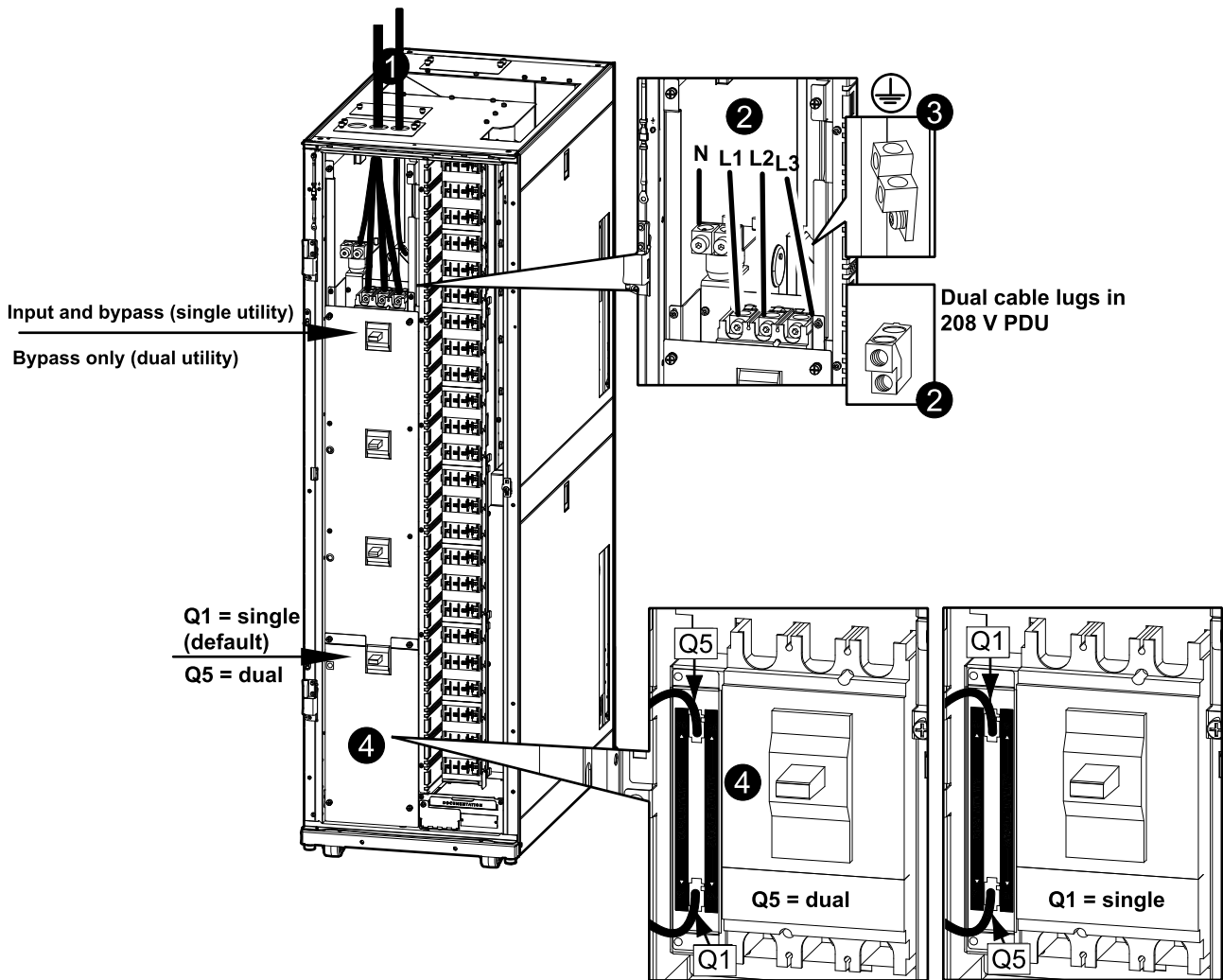

1. Route the conductors (input conductors in single utility systems or bypass conductors in dual utility systems) through the top of the PDU.
2. Connect the input/bypass conductors to the L1, L2, L3, N terminals.
NOTE: For a 208 V PDU, install the cables on the front hole of the dual cable lugs.
3. Connect the Equipment Ground Conductor (EGC) to the EGC terminal.
4. In dual utility systems, remove the plate and switch the cables around to have Q1 in the bottom and Q5 at the top. Use a Phillips screwdriver to remove the captive panel fasteners. Reinstall the plate.

Connect Power Conductors – Systems with PDU without Transformer — Bottom Cable Entry

⚠ CAUTION

HAZARD OF EXCESSIVE TERMINAL TEMPERATURE

Ensure clockwise phase rotation and neutral location of the power terminal bolt. The required torque values are: 62 Nm (45.73 lb-ft) for the Neutral, 31 Nm (22.86 lb-ft) for the 3 phases in the NSJ breaker, 50 Nm (36.88 lb-ft) for the 3 phases in the L-frame and L-frame Mission Critical breaker, 5.6 Nm (4.13 lb-ft) for the EGC.

Failure to follow these instructions can result in injury or equipment damage.

1. Route the conductors (input conductors in single utility systems and bypass conductors in dual utility systems) through the bottom of the PDU.
2. Connect the input/bypass conductors to the N, L1, L2, L3 terminals.
3. Connect the Equipment Ground Conductor (EGC) to the terminal.

4. In dual utility systems, remove the plate and switch the cables around to have Q1 in the bottom and Q5 at the top. Use a Phillips screwdriver to remove the captive panel fasteners. Reinstall the plate.

Rear view of the PDU

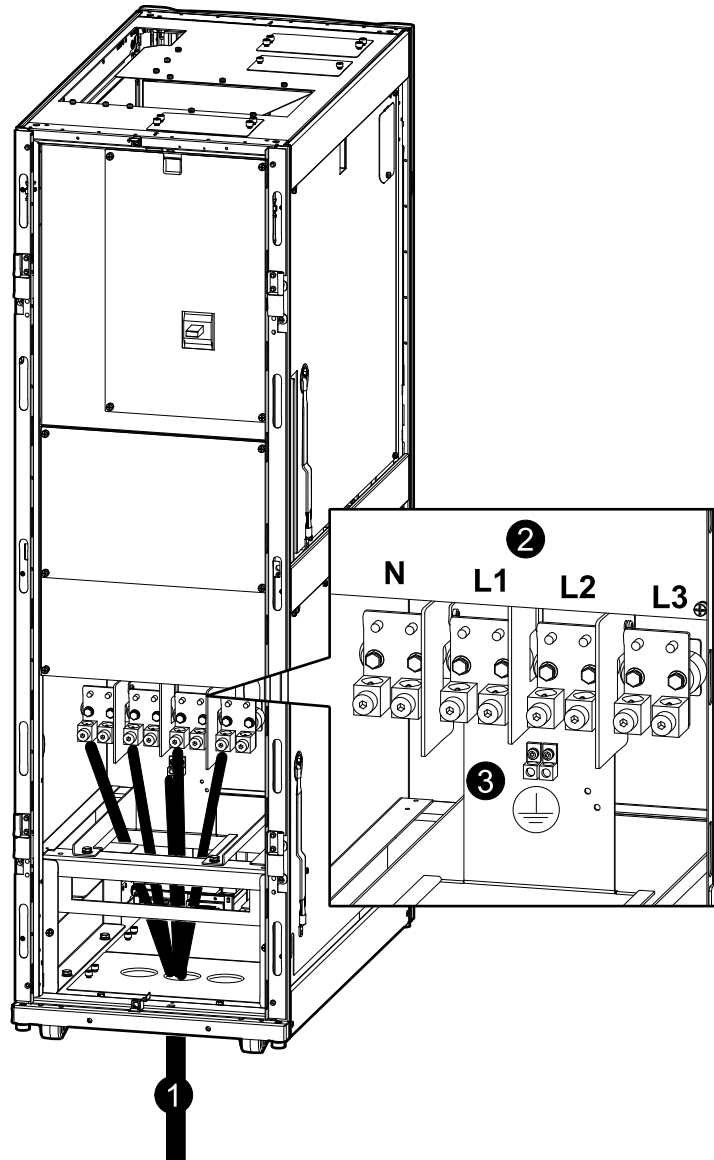

Front view of the PDU

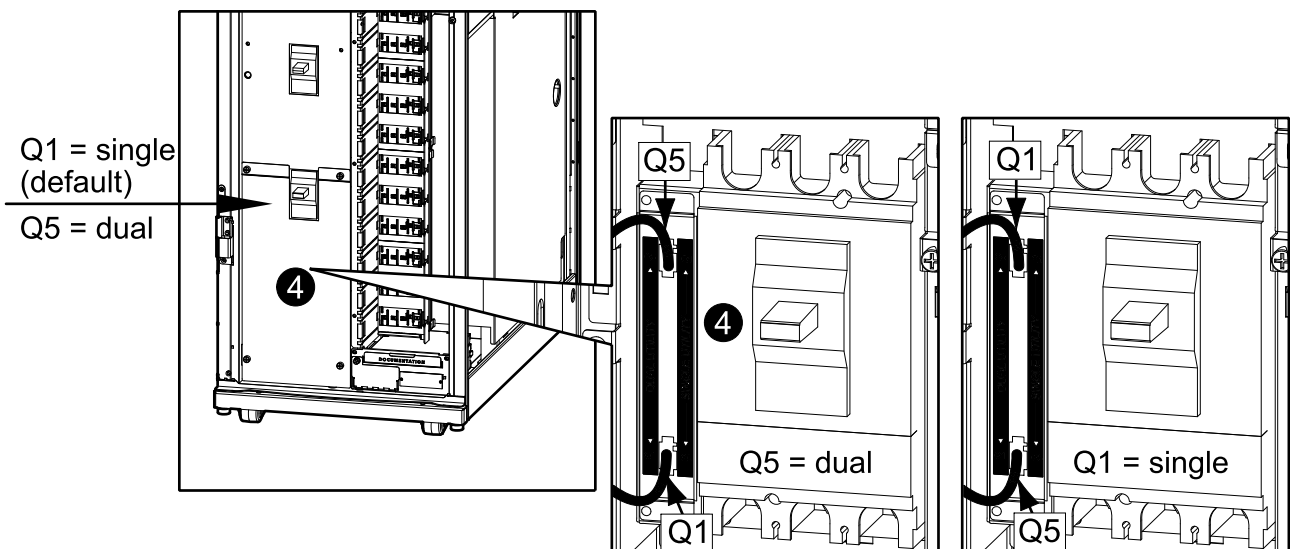

Connect Power Conductors between the UPS and the PDU

1. Open the rear doors of the PDU and the UPS.
2. Remove the cover from the PDU to get access to the power conductors. Use a Phillips screwdriver to remove the captive panel fasteners.

Rear view of the PDU

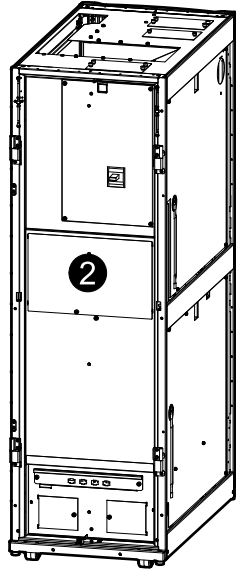

3. Before running the conductors, loosen the three fasteners on each UPS conductor relief next to the PDU.
4. Cut the conductor ties and route the output and bypass/input conductors (input in single utility systems and bypass in dual utility systems) to the UPS through the conductor reliefs. Lay the conductors neatly to minimize conductor build-up.

Rear view of the System

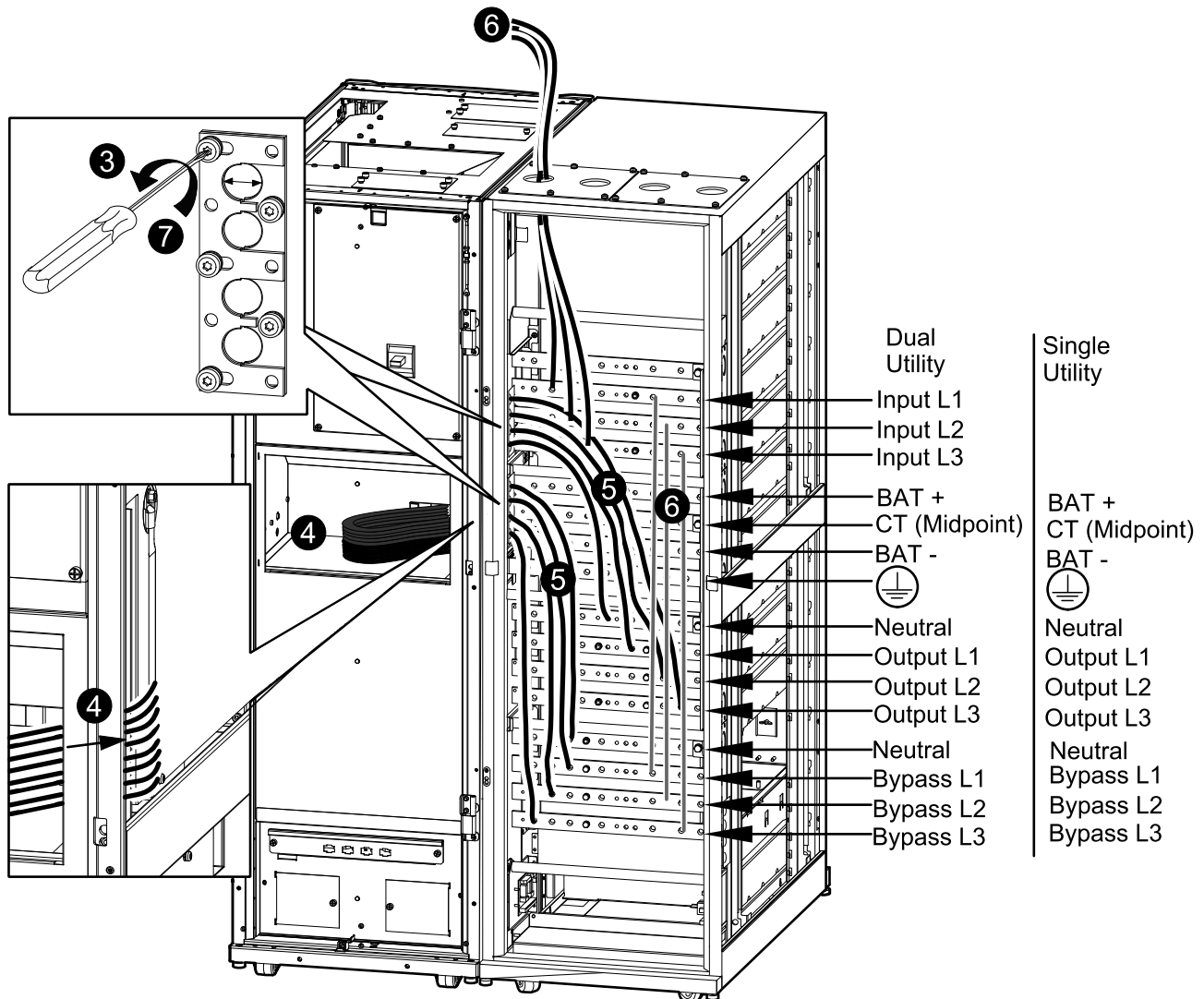

5. Connect the output and bypass/input conductors from the PDU.
6. Do one of the following:
 - In dual utility systems, connect the input conductors to the bypass busbars (L1, L2, L3).
 - In single utility systems, install the three cables (0W3617) included with the unit. Connect bypass L3 to input L3, bypass L2 to input L2 and bypass L1 to input L1.
7. Tighten the three fasteners on each conductor relief.
8. Reinstall the cover in the PDU and close the rear doors.

Connect Output Cables to the Subfeed Breaker

⚠ CAUTION

HAZARD OF EXCESSIVE TERMINAL TEMPERATURE

Ensure clockwise phase rotation and neutral location of the power terminal bolt. Wire size and torque are specified on breaker.

Failure to follow these instructions can result in injury or equipment damage.

1. Loosen the four bolts and remove the inner cover to get access to the subfeed breaker.

Rear view of the PDU

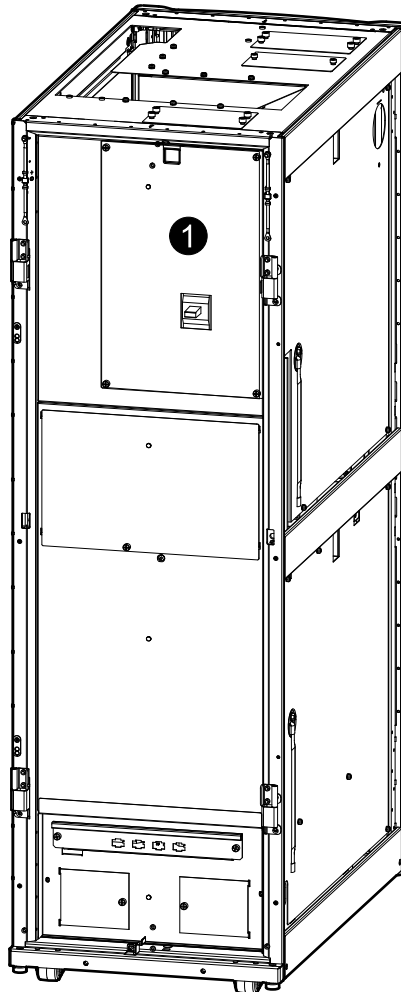

2. Route the output cables through the top of the PDU and connect them to the subfeed breaker.

Rear view of the PDU

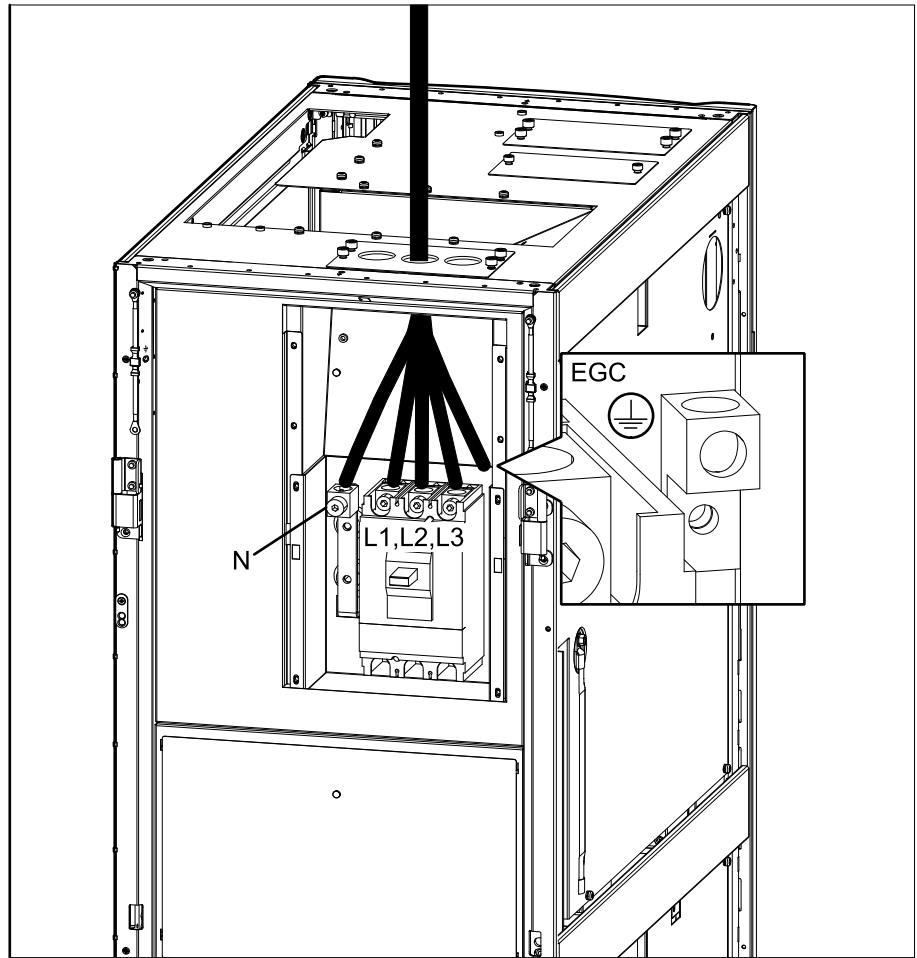

Install the Power Distribution Module

⚠ DANGER

HAZARD OF ELECTRIC SHOCK

Turn off all power supplying this equipment before working on the equipment or before installing or removing a power distribution module.

Failure to follow these instructions will result in death or serious injury.

⚠ CAUTION

RISK OF INJURY OR EQUIPMENT DAMAGE

- Install only Schneider Electric power distribution modules with matching output voltage.
- Install power distribution modules starting from the bottom of the panel to avoid cable congestion.
- Save filler plates for future reuse. If a module is removed, a filler plate must be installed to cover the open busbar.
- Slot locks (attached together in pairs) must always be installed on all power distribution module positions in the panel whether filled by a power distribution module or a filler plate.
- Make sure all breakers on the power distribution modules being installed are in the OFF (open) position.

Failure to follow these instructions can result in injury or equipment damage.

NOTE: Power distribution modules and backplanes are color-coded: black for 120/208 V and grey for 240/415 V. The color of the backplane and the color of the rear of the power distribution module must be black for 120/208 V. The slot lock key can be stored in the documentation tray.

1. Insert the slot key in the slot lock.

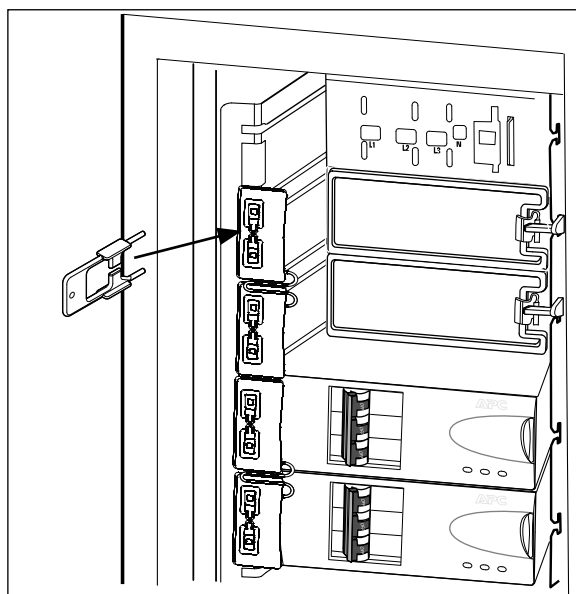

2. Squeeze the sides of the key inwards to grasp the slot lock firmly.

3. Pull the slot key out while squeezing to extract the slot lock from the slot.

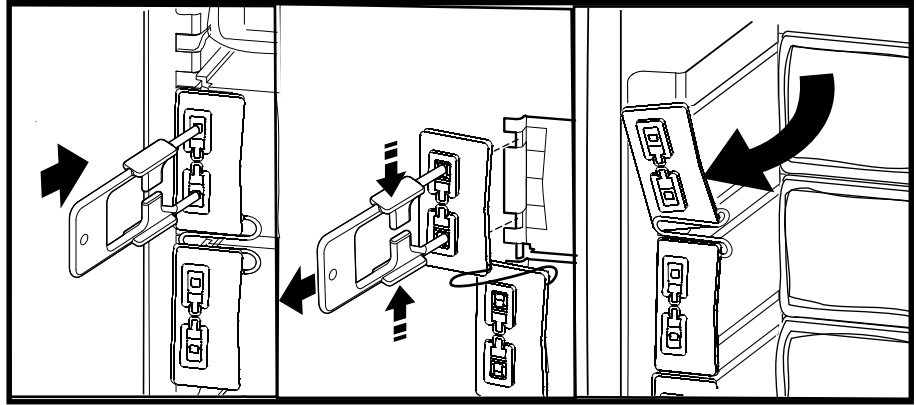

4. To remove a filler plate: Press down on the filler plate clip to release the locking mechanism and pull the filler plate directly towards you and along the slot until it is free of the slot.

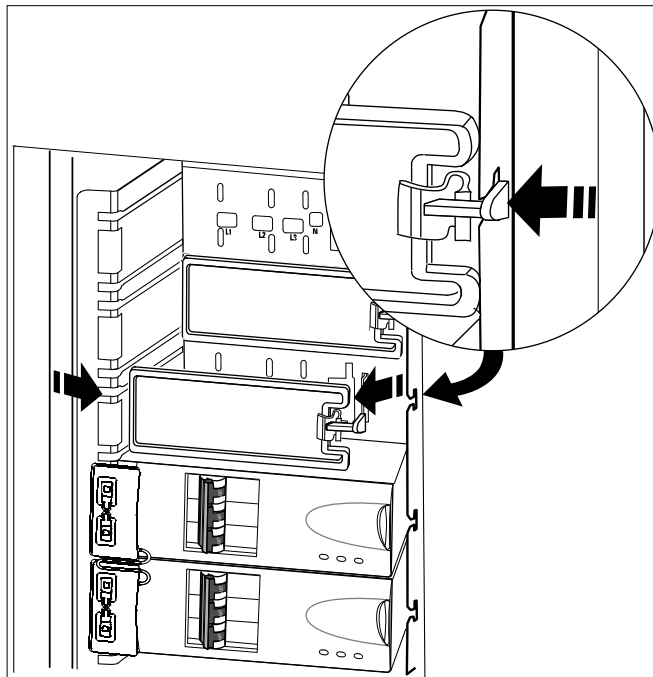

5. Press down on the red button to open the latch on the front of the power distribution module.
6. Route the cable on the power distribution module through the top of the cabinet.

NOTE: Leave a minimum of 178 mm of slack in the cable behind the module. The slack is useful in case the module is ever removed or replaced. (254 to 508 mm (10 to 20 in) is recommended, but space restrictions in the PDU and cable diameter size will cause the amount of slack to necessarily vary.)

NOTE: When installing power distribution modules near the top of the panel, feed the cable first, pull up the slack, and then secure the module to the busbar to avoid cable congestion between the panel and the slot.

7. Slide the power distribution module into the panel via the slots. Make sure that you slide it all the way in, so it connects with the busbar.

- Secure the latch to lock the power distribution module onto the busbar.

Front view of the PDU

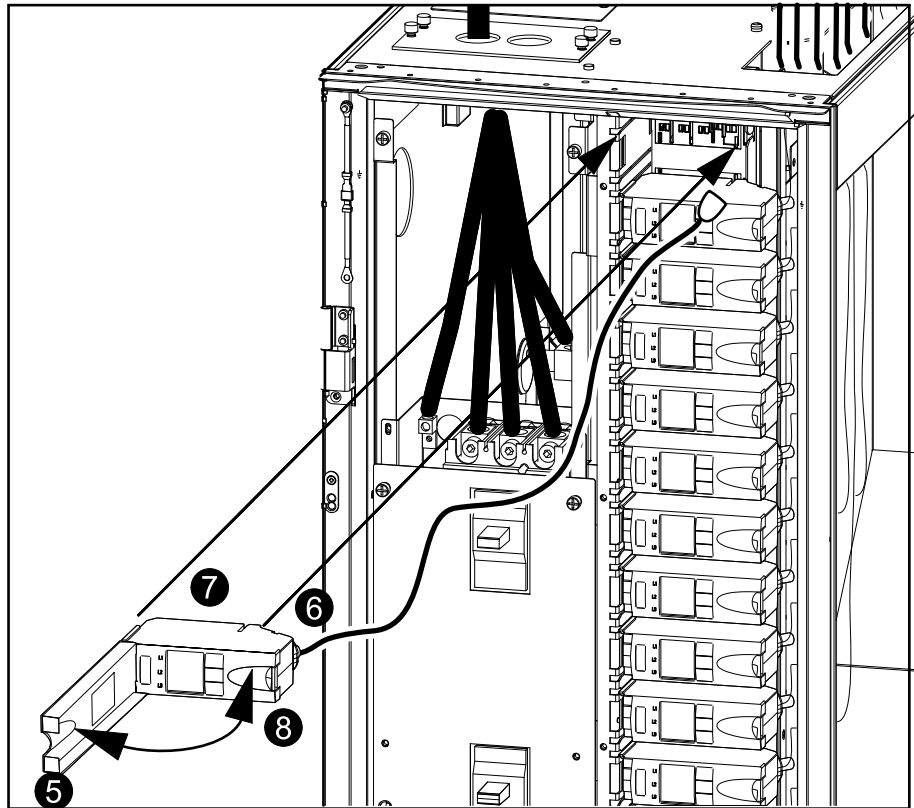

- Set the required breakers on the new power distribution module to the ON (closed) position.
- Only for power distribution positions that are empty:
 - Insert the bottom tab of the filler plate into the slot and slide the filler plate towards the busbar.
 - Snap the filler plate into position and check that the latch is secure.

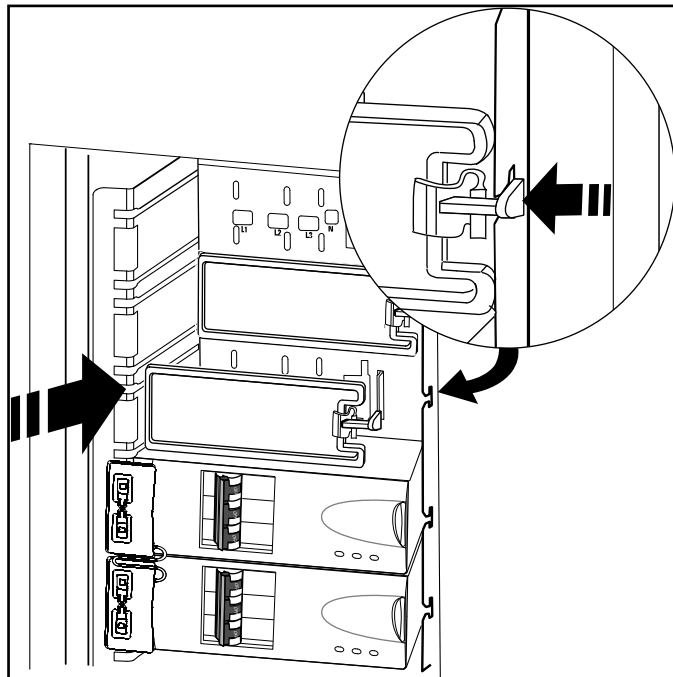

11. Install the slot lock by pressing it into the slots.

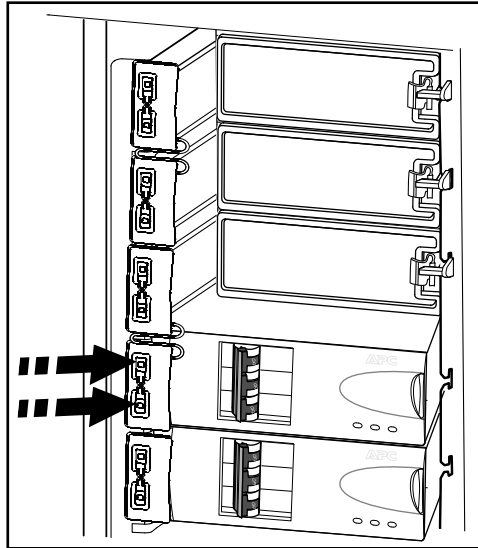

12. Connect the power distribution module cable to the appropriate equipment.

Connect Communication Wires in Installations with PDU

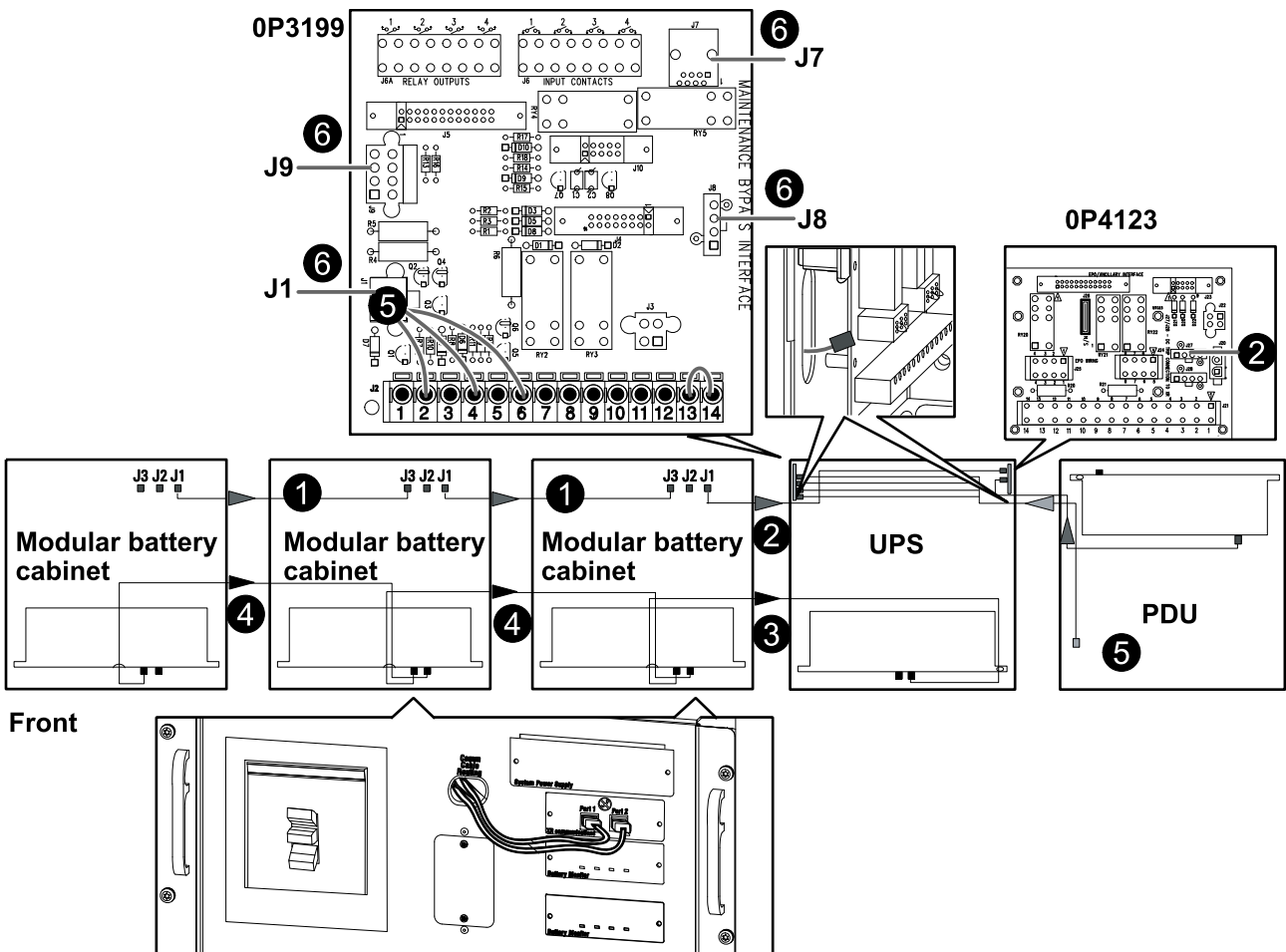

1. Route the battery breaker trip cable from J1 in the first modular battery cabinet to the J3 port in the next modular battery cabinet. Repeat the procedure for all modular battery cabinets.
2. Route the battery breaker trip cable from J1 in the last modular battery cabinet to J27 on the EPO/ancillary interface board (0P4123) in the UPS (for remote modular battery cabinet the length of the cable must not exceed 50 m).

3. Route the communication cable from the UPS XR Communications port 1 to port 2 in the first modular battery cabinet nearest the UPS in the row (for remote modular battery cabinets, the length of the communications cable from the UPS must not exceed 50 m).
4. Route the communication cable from XR Communications port 1 in each modular battery cabinet to port 2 in the next modular battery cabinet. Remove the terminator when necessary.
5. In installations with PDU, remove jumper wire harness between J1 and J2.
6. Route the four PDU communication cables from the PDU to J7, J8, J9, and J1 on the maintenance bypass interface board (0P3199) in the UPS.

Procedure for Systems with PDU with Transformer

NOTE: For bottom cable entry systems, make sure to follow *Install the Internal Conductors for Bottom Entry Systems in Installations with PDU without Transformer*, page 21 before proceeding to *Perform Equipotential Bonding*, page 22.

Overview of Single Utility System with Top Cable Entry

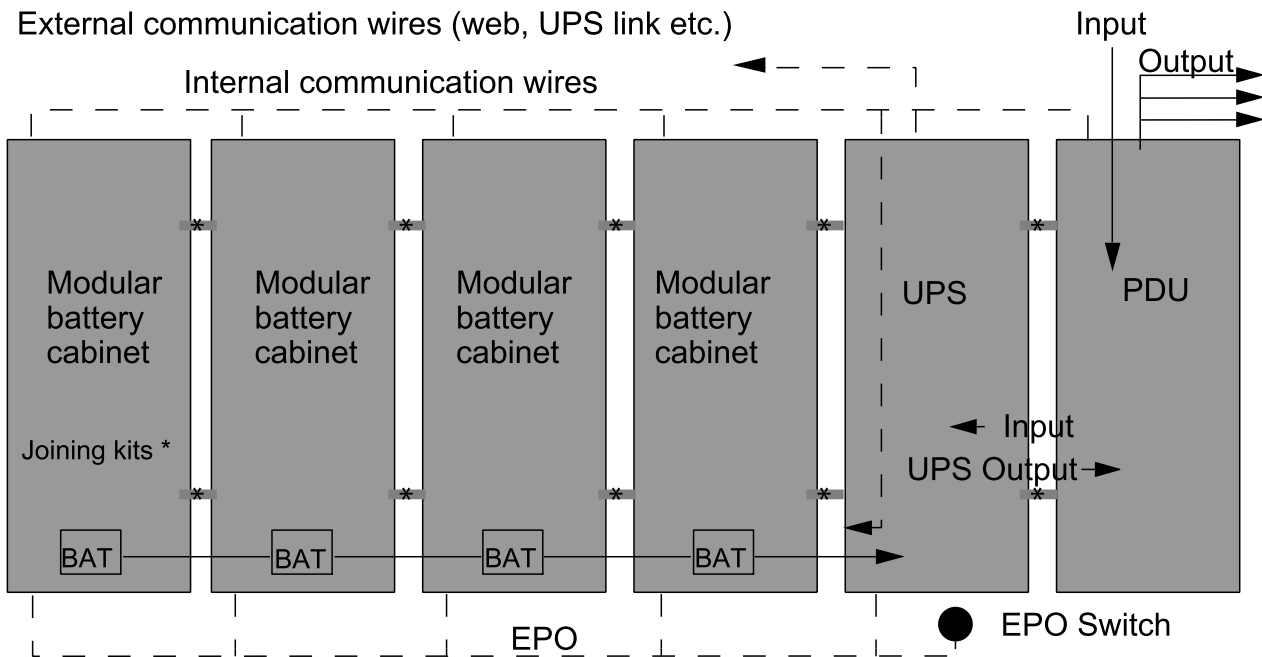

Overview of Single Utility System with Bottom Cable Entry

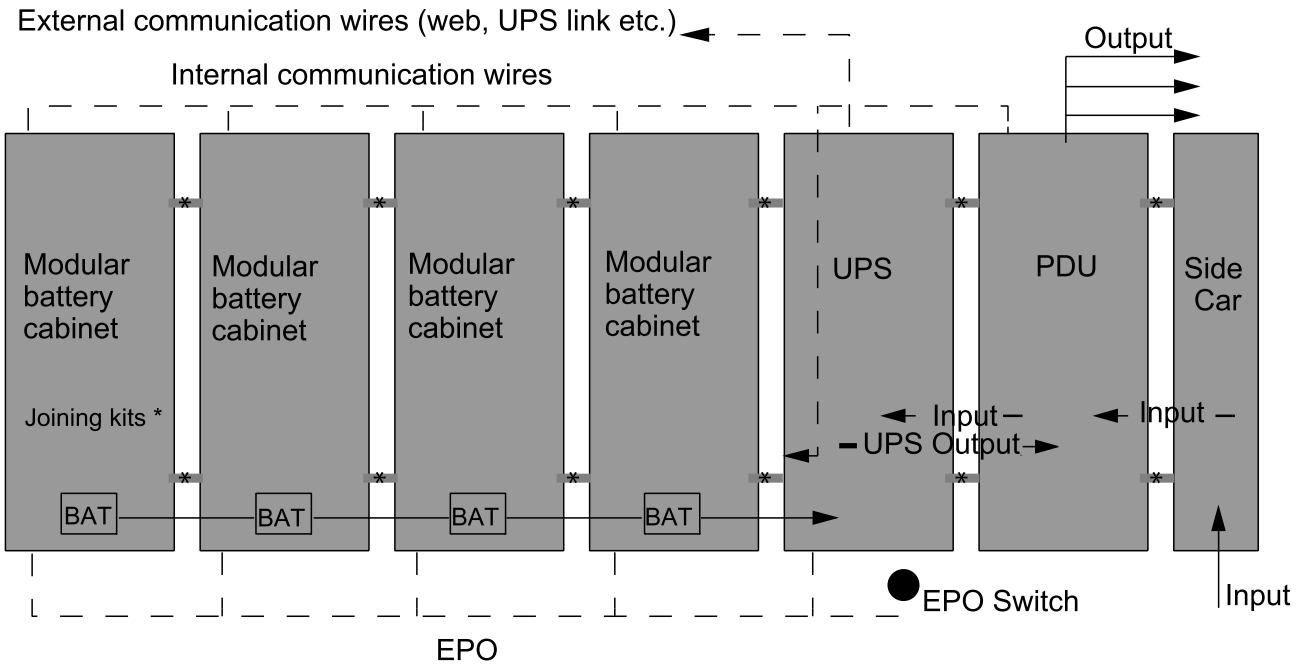

Overview of Dual Utility System with Top Cable Entry

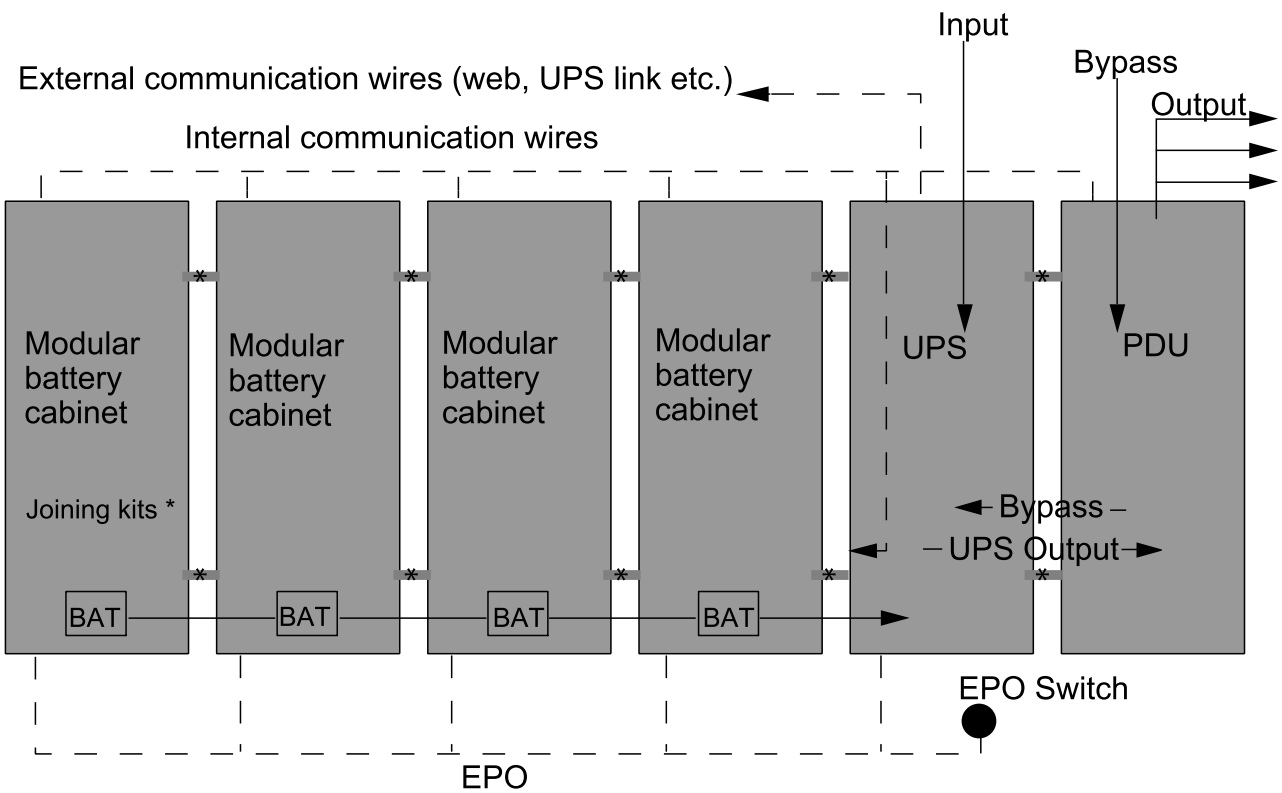

Overview of Dual Utility System with Bottom Cable Entry

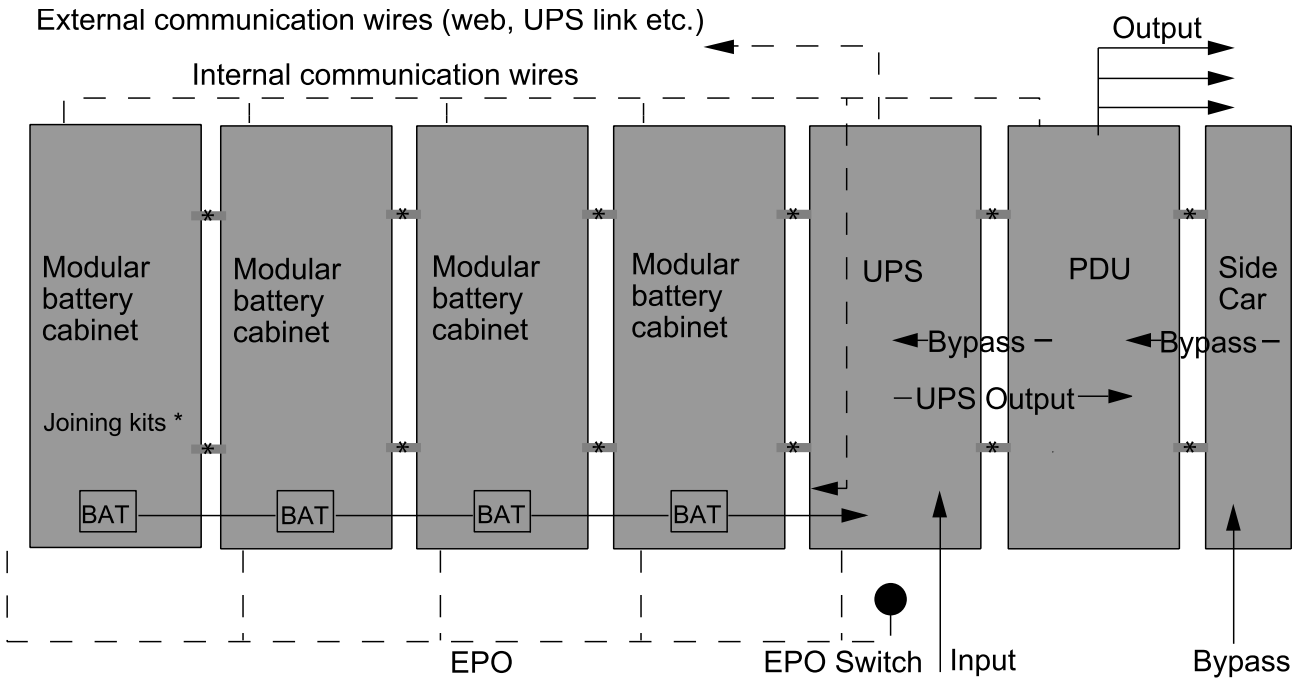

Prepare for Cables – Systems with PDU with Transformer

1. Open the rear door of the UPS.
2. Remove all four covers, starting from the top, by loosening the two screws in each cover. Note the orientation of the covers.
3. Lift the cover up and out.

Rear view of the UPS

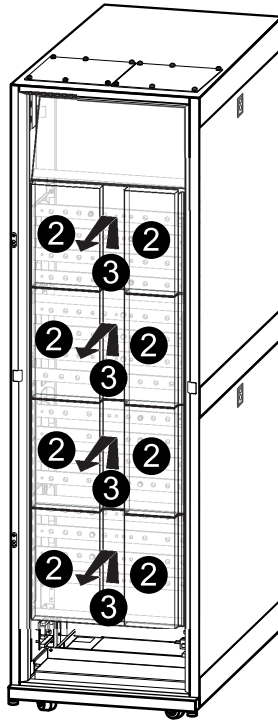

The following steps are only applicable to systems with the PDU placed to the left of the UPS (front view):

4. Remove the two top cable reliefs from the left side and save for step 7.
5. Remove the bottom cable relief from the right side and save for step 8.
6. Remove the neutral busbar from the right side (rear view) of the UPS by loosening the four bolts, and mount the busbar on the left side of the UPS.
7. Mount the cable reliefs from step 4 on the right side (rear view).

8. Mount the cable relief from step 5 on the left side (rear view).

Rear view of the UPS

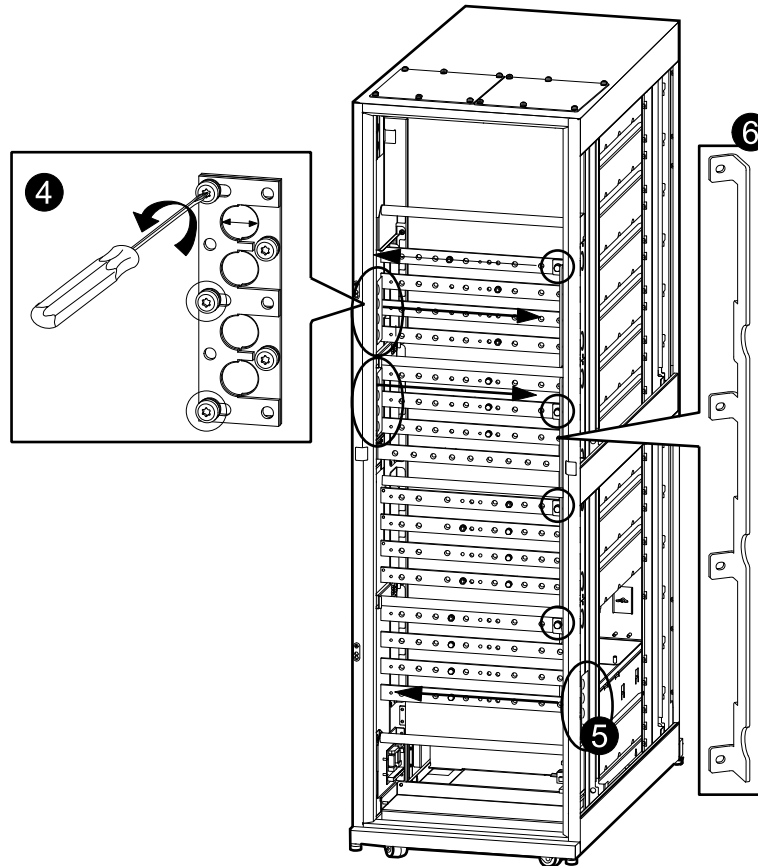

9. Open the front door of the PDU.
10. Remove the upper cover. Use a Phillips screwdriver to remove the captive panel fasteners.

11. In bottom entry systems, open the front door and remove the inner door of the sidecar.

Front View

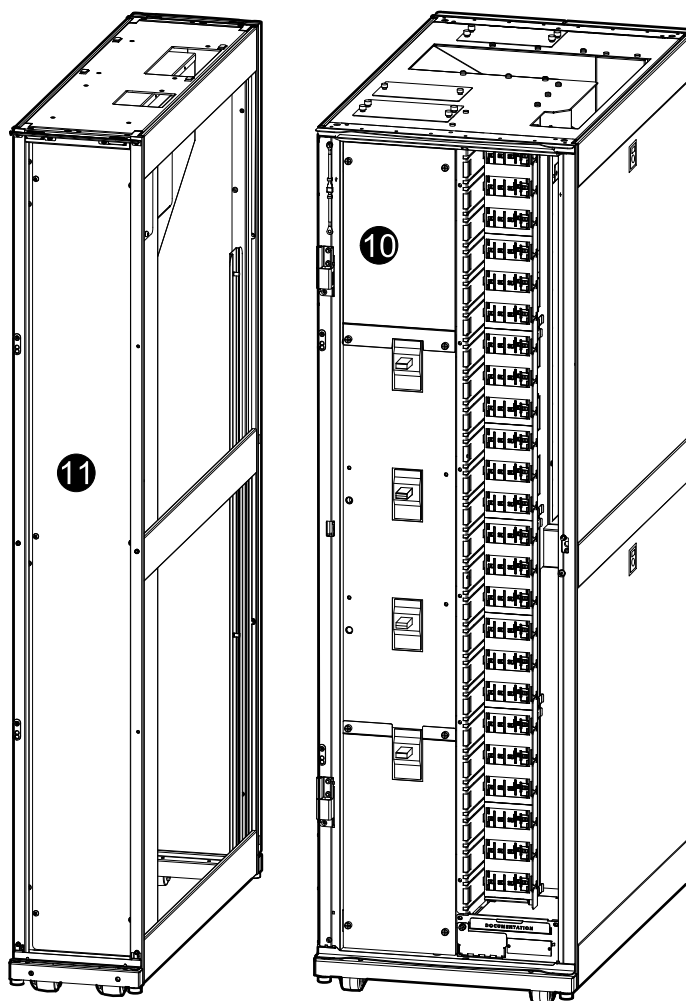

12. In bottom entry systems, exchange the chase nipple and the cover plate (if necessary) to have the chase nipple placed on the side against the PDU.
13. In bottom entry systems, remove the PDU side panel from the side placed against the sidecar.

Front view of sidecar

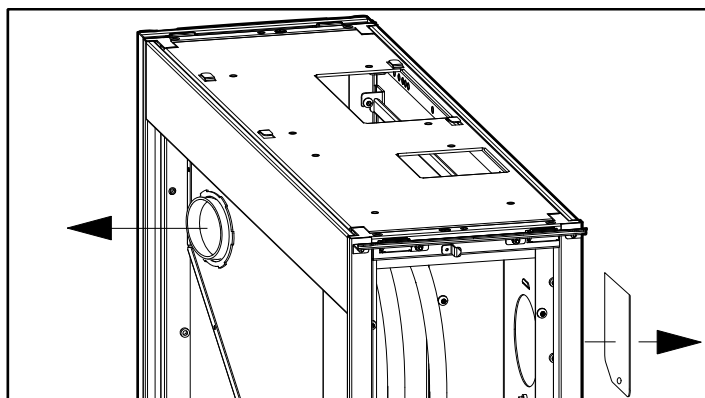

Make Holes in the Top Cover of the PDU

⚠ DANGER

HAZARD OF ELECTRIC SHOCK, EXPLOSION, OR ARC FLASH

Do not drill or cut holes for cables or conduits with the covers installed and do not drill in close proximity to the UPS.

Failure to follow these instructions will result in death or serious injury.

1. Remove the dedicated cover plate for power cables.

Front view of the PDU

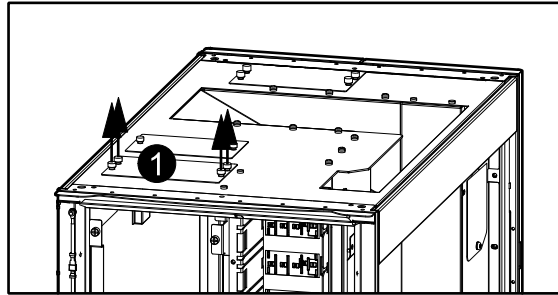

2. Drill holes in the plate for conduits. Reinstall the plate with the conduits installed.

Front view of the PDU

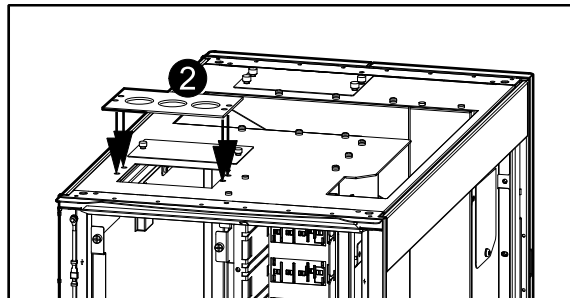

3. Remove the dedicated cover plate for subfeed breaker cables.

Rear view of the PDU

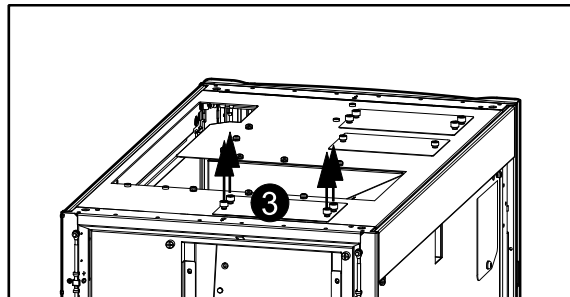

4. Drill holes in the plate for conduits and reinstall the plate with the conduits installed.

Rear view of the PDU

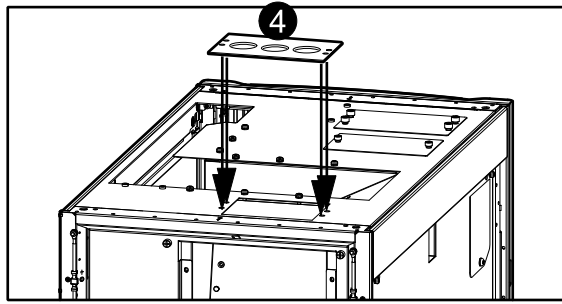

Make Holes in the Bottom of the Sidecar

⚠ DANGER

HAZARD OF ELECTRIC SHOCK, EXPLOSION, OR ARC FLASH

Do not drill or cut holes for cables or conduits with the covers installed and do not drill in close proximity to the UPS.

Failure to follow these instructions will result in death or serious injury.

1. Remove the dedicated cover plate.

Front view of the sidecar

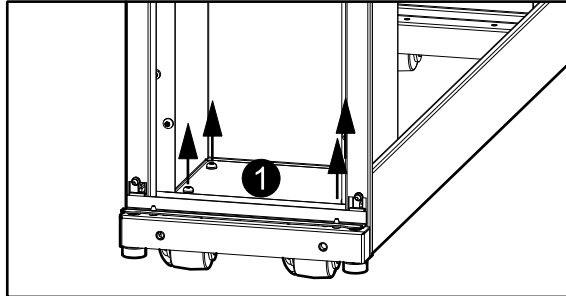

2. Drill holes in the plate for conduits and reinstall the plate with the conduits installed.

Front view of the sidecar

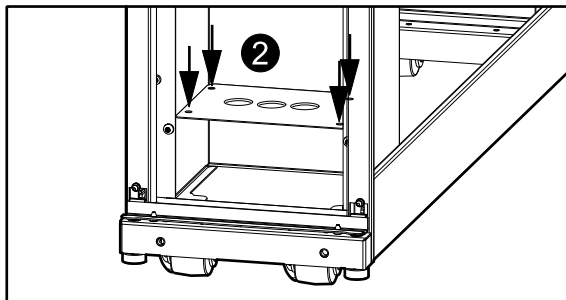

Open Holes in the Side of the PDU

⚠ DANGER

HAZARD OF ELECTRIC SHOCK, EXPLOSION, OR ARC FLASH

Do not drill or cut holes for cables or conduits with the covers installed and do not drill in close proximity to the UPS.

Failure to follow these instructions will result in death or serious injury.

1. Loosen the bolt and remove the cover plate for side access in either the left or right side of the PDU (depending on system configuration).

Front view of the PDU

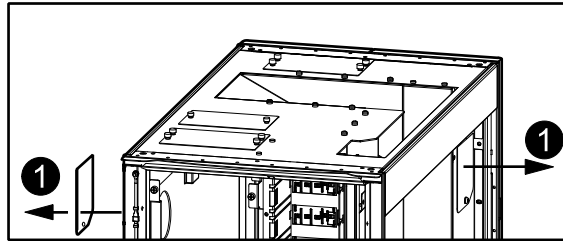

2. Install the chase nipple (from the sidecar kit) in either the left or right side of the PDU (depending on system configuration). If the chase nipple protrudes beyond the side plane of the cabinet, then reverse the direction so that it does not interfere with the chase nipple from the sidecar.

Front view of the PDU

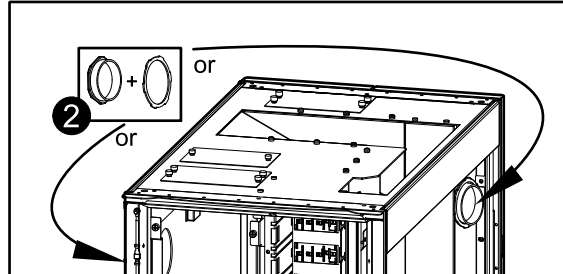

Connect Power Conductors – Systems with PDU with Transformer

⚠ CAUTION

HAZARD OF EXCESSIVE TERMINAL TEMPERATURE

Ensure clockwise phase rotation. The required torque value is 56.5 Nm (41.67 lb-ft).

Failure to follow these instructions can result in injury or equipment damage.

NOTE: For top entry systems, go directly to step 4.

1. In bottom entry systems: Route the conductors (input conductors in single utility systems or bypass conductors in dual utility systems) through the bottom of the sidecar.
2. In bottom entry systems: Connect the input/bypass conductors to the L1, L2, L3, EGC, and GEC terminals and torque to specifications on label.

Front view of the sidecar

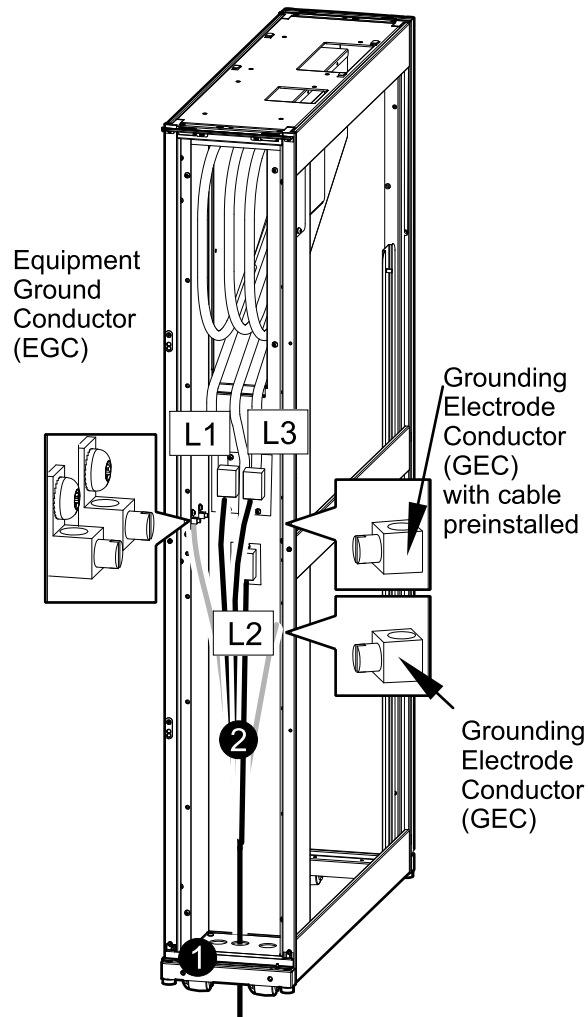

3. In bottom entry systems: Take the cables that are preinstalled in the sidecar and route them through the left or right side (depending on configuration) into the PDU.

Front view of the sidecar

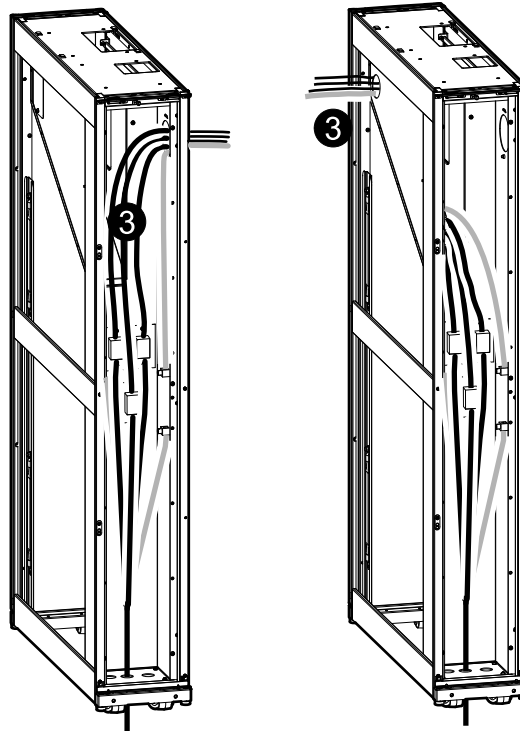

4. Route the conductors (input conductors in single utility systems or bypass conductors in dual utility systems) through the top of the PDU in top cable entry systems or through the side from the sidecar in bottom cable entry systems.
5. Connect the input/bypass conductors to the L1, L2, L3, Grounding Electrode Conductor (GEC) terminals.
NOTE: For a 208 V PDU, install the cables on the front hole of the dual cable lugs.
6. Connect the Equipment Ground Conductor (EGC) to the terminal.

7. In dual utility systems, remove the plate and switch the cables around to have Q1 in the bottom and Q5 at the top. Use a Phillips screwdriver to remove the captive panel fasteners. Reinstall the plate.

Front view of the PDU

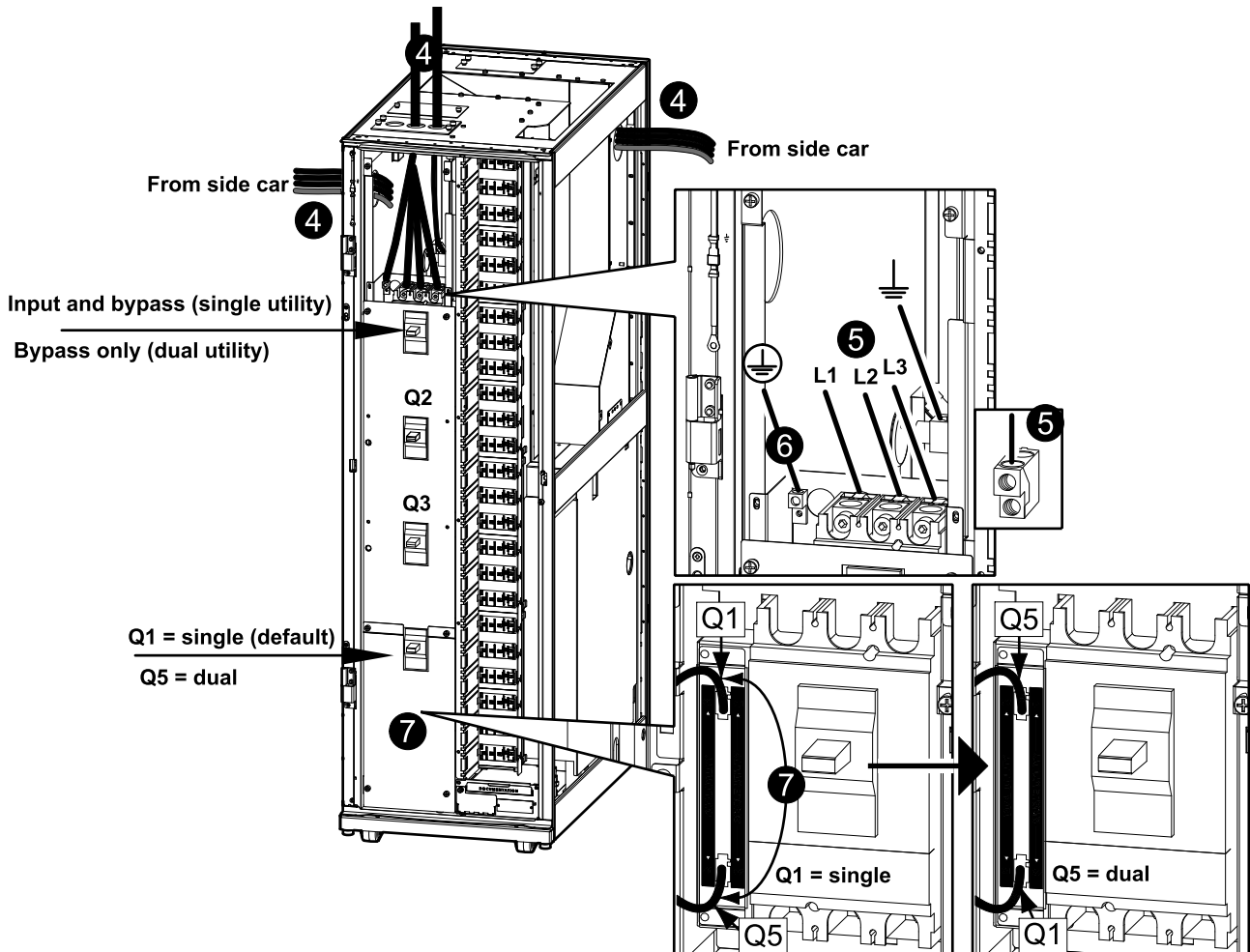

Connect Power Conductors between the UPS and the PDU

1. Open the rear doors of the PDU and the UPS.

2. Remove the cover from the PDU to get access to the power conductors. Use a Phillips screwdriver to remove the captive panel fasteners.

Rear view of the PDU

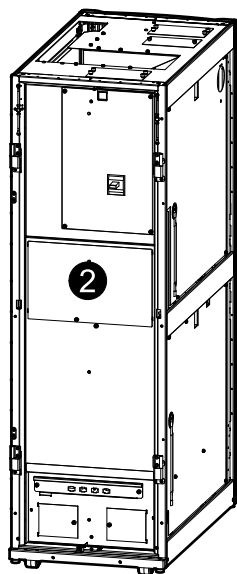

3. Before running the conductors, loosen the three fasteners on each UPS conductor relief next to the PDU.
4. Cut the conductor ties and route the output and bypass/input conductors (input in single utility systems and bypass in dual utility systems) to the UPS through the conductor reliefs. Lay the conductors neatly to minimize conductor build-up.

Rear view of the System

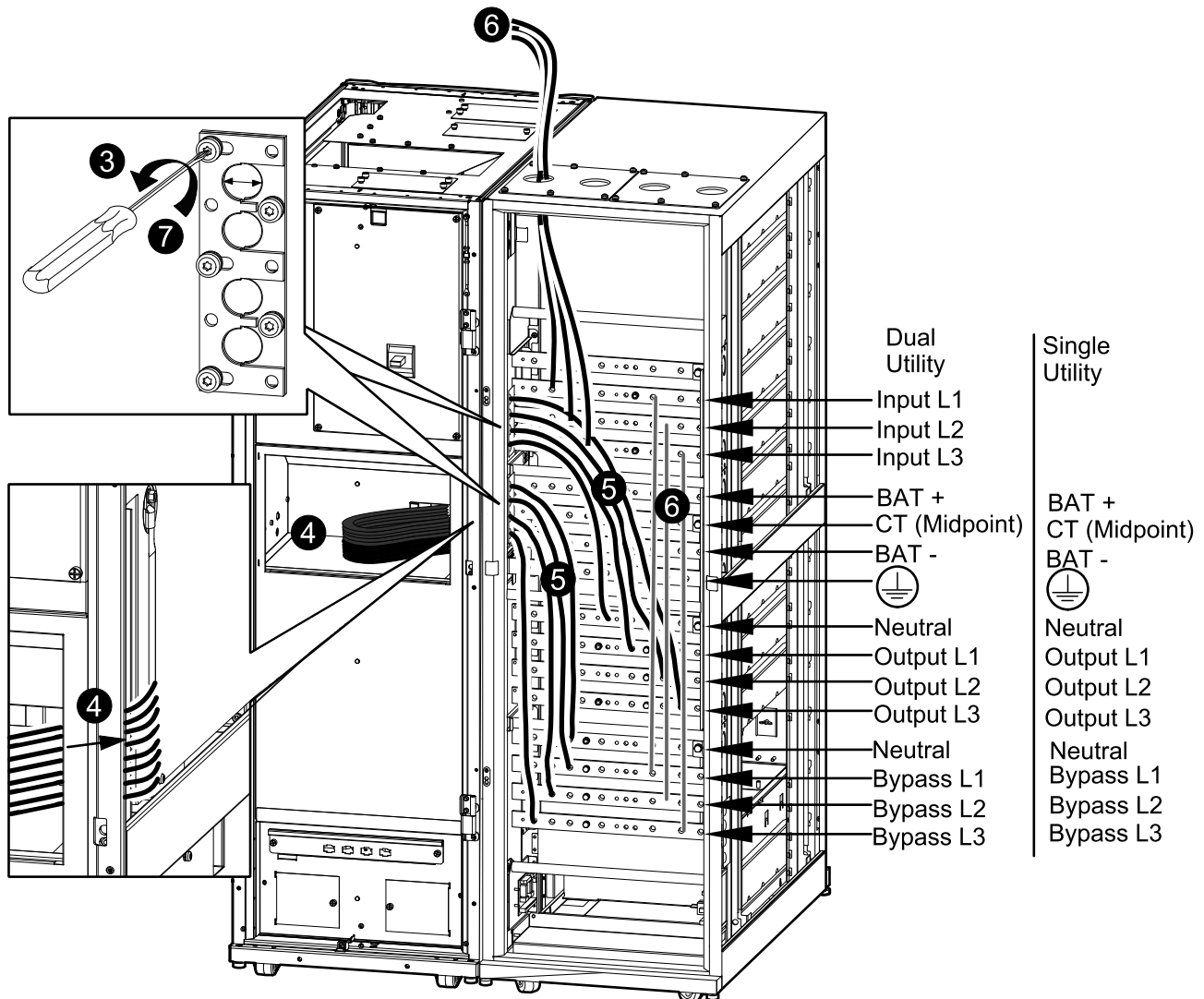

5. Connect the output and bypass/input conductors from the PDU.
6. Do one of the following:
 - In dual utility systems, connect the input conductors to the bypass busbars (L1, L2, L3).
 - In single utility systems, install the three cables (0W3617) included with the unit. Connect bypass L3 to input L3, bypass L2 to input L2 and bypass L1 to input L1.
7. Tighten the three fasteners on each conductor relief.
8. Reinstall the cover in the PDU and close the rear doors.

Connect Output Cables to the Subfeed Breaker

⚠ CAUTION

HAZARD OF EXCESSIVE TERMINAL TEMPERATURE

Ensure clockwise phase rotation and neutral location of the power terminal bolt. Wire size and torque are specified on breaker.

Failure to follow these instructions can result in injury or equipment damage.

1. Loosen the four bolts and remove the inner cover to get access to the subfeed breaker.

Rear view of the PDU

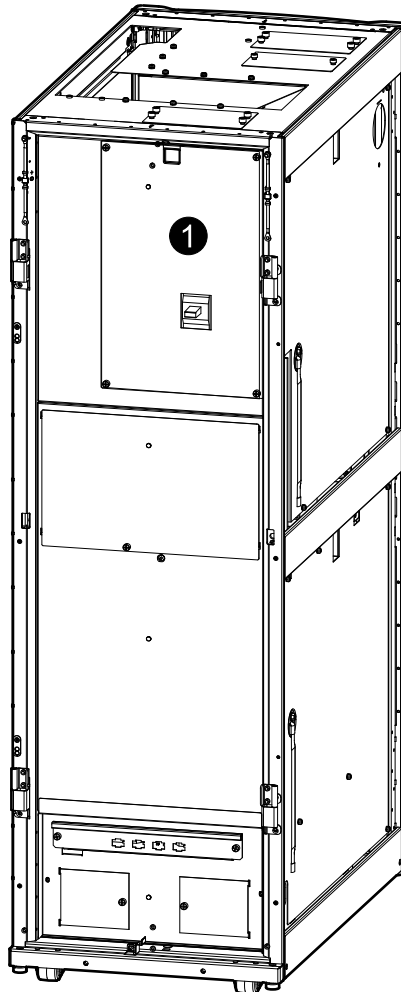

2. Route the output cables through the top of the PDU and connect them to the subfeed breaker.

Rear view of the PDU

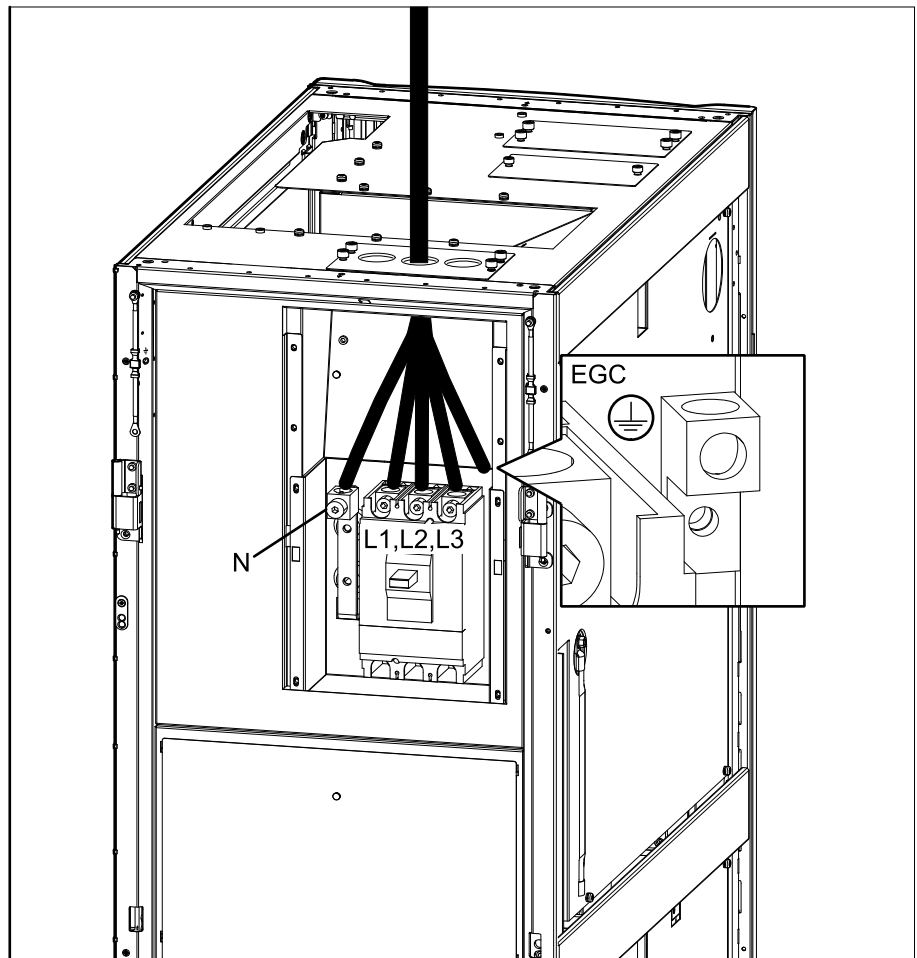

Install the Power Distribution Module

⚠ DANGER

HAZARD OF ELECTRIC SHOCK

Turn off all power supplying this equipment before working on the equipment or before installing or removing a power distribution module.

Failure to follow these instructions will result in death or serious injury.

⚠ CAUTION

RISK OF INJURY OR EQUIPMENT DAMAGE

- Install only Schneider Electric power distribution modules with matching output voltage.
- Install power distribution modules starting from the bottom of the panel to avoid cable congestion.
- Save filler plates for future reuse. If a module is removed, a filler plate must be installed to cover the open busbar.
- Slot locks (attached together in pairs) must always be installed on all power distribution module positions in the panel whether filled by a power distribution module or a filler plate.
- Make sure all breakers on the power distribution modules being installed are in the OFF (open) position.

Failure to follow these instructions can result in injury or equipment damage.

NOTE: Power distribution modules and backplanes are color-coded: black for 120/208 V and grey for 240/415 V. The color of the backplane and the color of the rear of the power distribution module must be black for 120/208 V. The slot lock key can be stored in the documentation tray.

1. Insert the slot key in the slot lock.

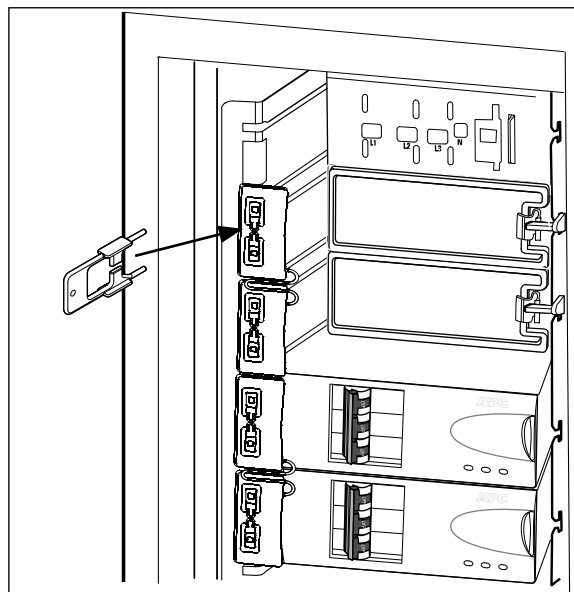

2. Squeeze the sides of the key inwards to grasp the slot lock firmly.

3. Pull the slot key out while squeezing to extract the slot lock from the slot.

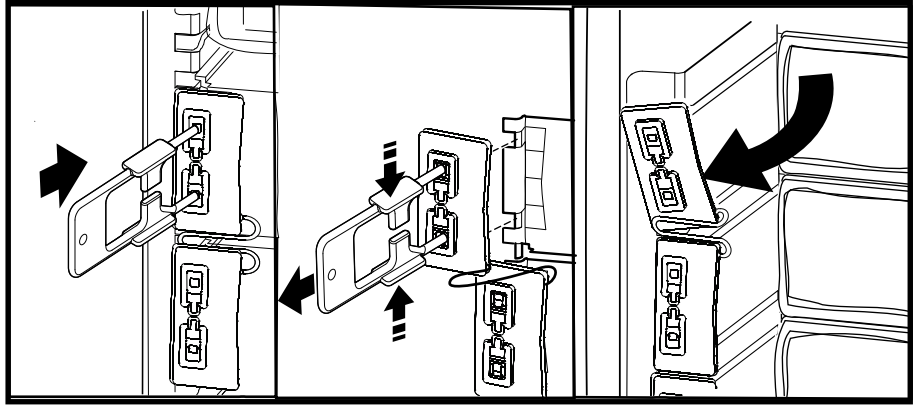

4. To remove a filler plate: Press down on the filler plate clip to release the locking mechanism and pull the filler plate directly towards you and along the slot until it is free of the slot.

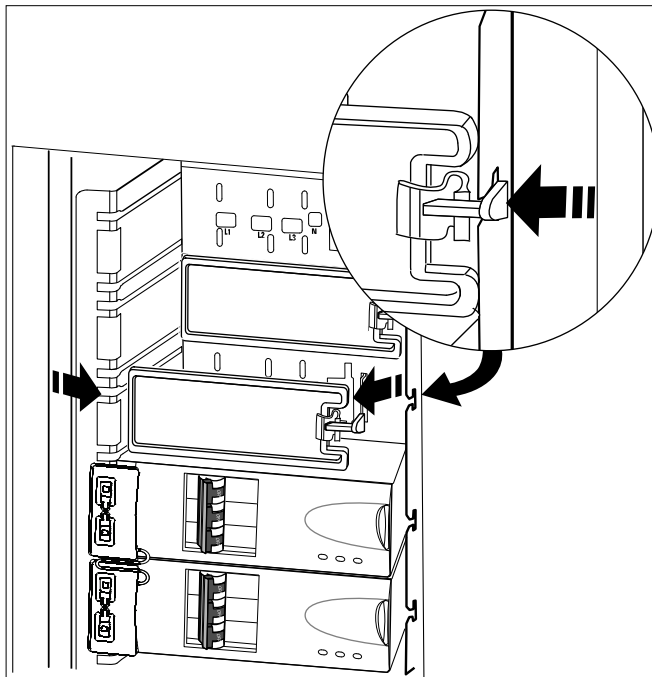

5. Press down on the red button to open the latch on the front of the power distribution module.
6. Route the cable on the power distribution module through the top of the cabinet.

NOTE: Leave a minimum of 178 mm of slack in the cable behind the module. The slack is useful in case the module is ever removed or replaced. (254 to 508 mm (10 to 20 in) is recommended, but space restrictions in the PDU and cable diameter size will cause the amount of slack to necessarily vary.)

NOTE: When installing power distribution modules near the top of the panel, feed the cable first, pull up the slack, and then secure the module to the busbar to avoid cable congestion between the panel and the slot.

7. Slide the power distribution module into the panel via the slots. Make sure that you slide it all the way in, so it connects with the busbar.

8. Secure the latch to lock the power distribution module onto the busbar.

Front view of the PDU

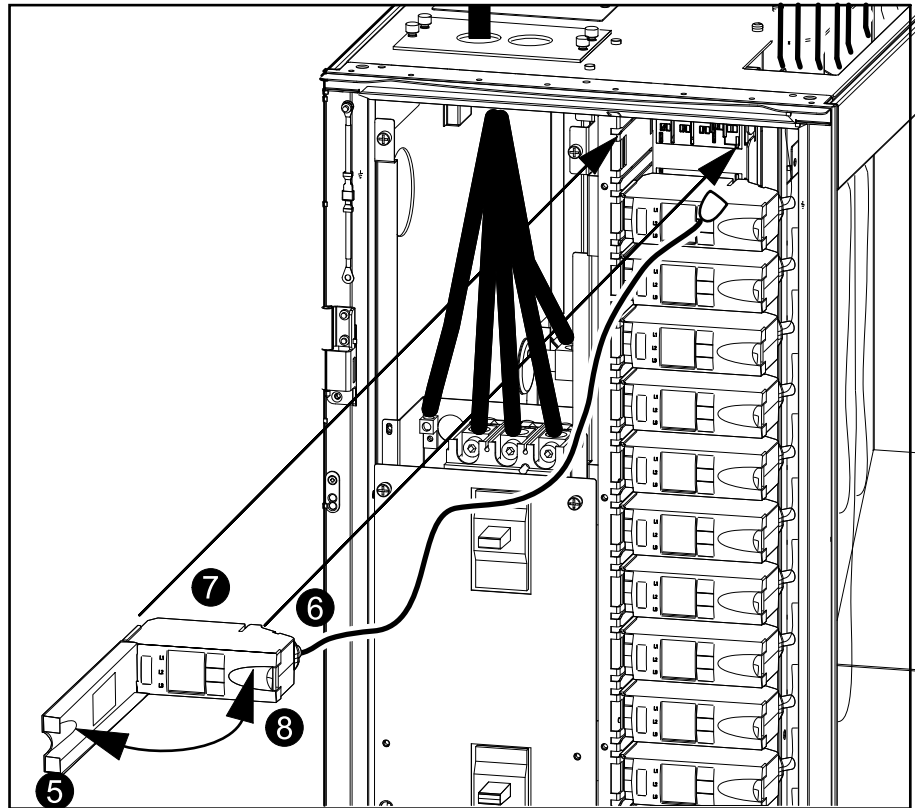

9. Set the required breakers on the new power distribution module to the ON (closed) position.
10. Only for power distribution positions that are empty:
 - a. Insert the bottom tab of the filler plate into the slot and slide the filler plate towards the busbar.
 - b. Snap the filler plate into position and check that the latch is secure.

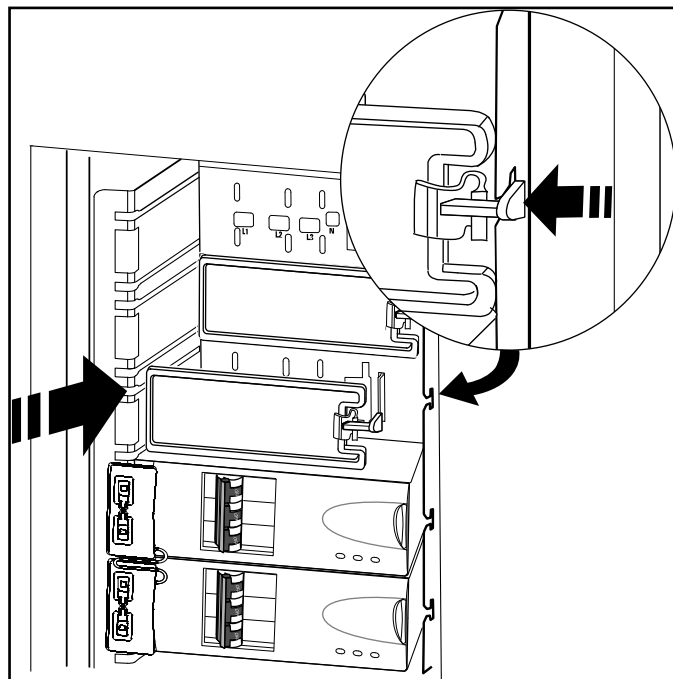

11. Install the slot lock by pressing it into the slots.

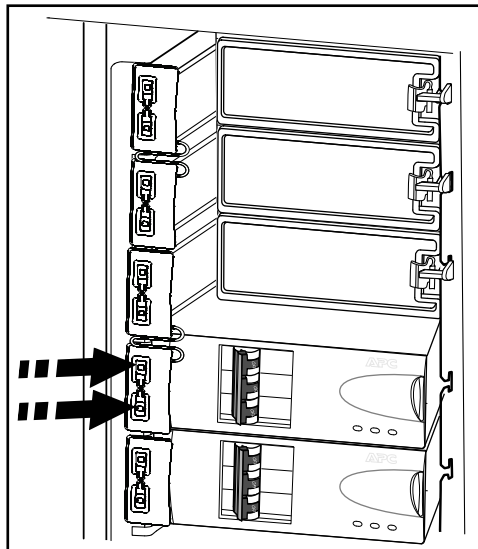

12. Connect the power distribution module cable to the appropriate equipment.

Connect Communication Wires in Installations with PDU

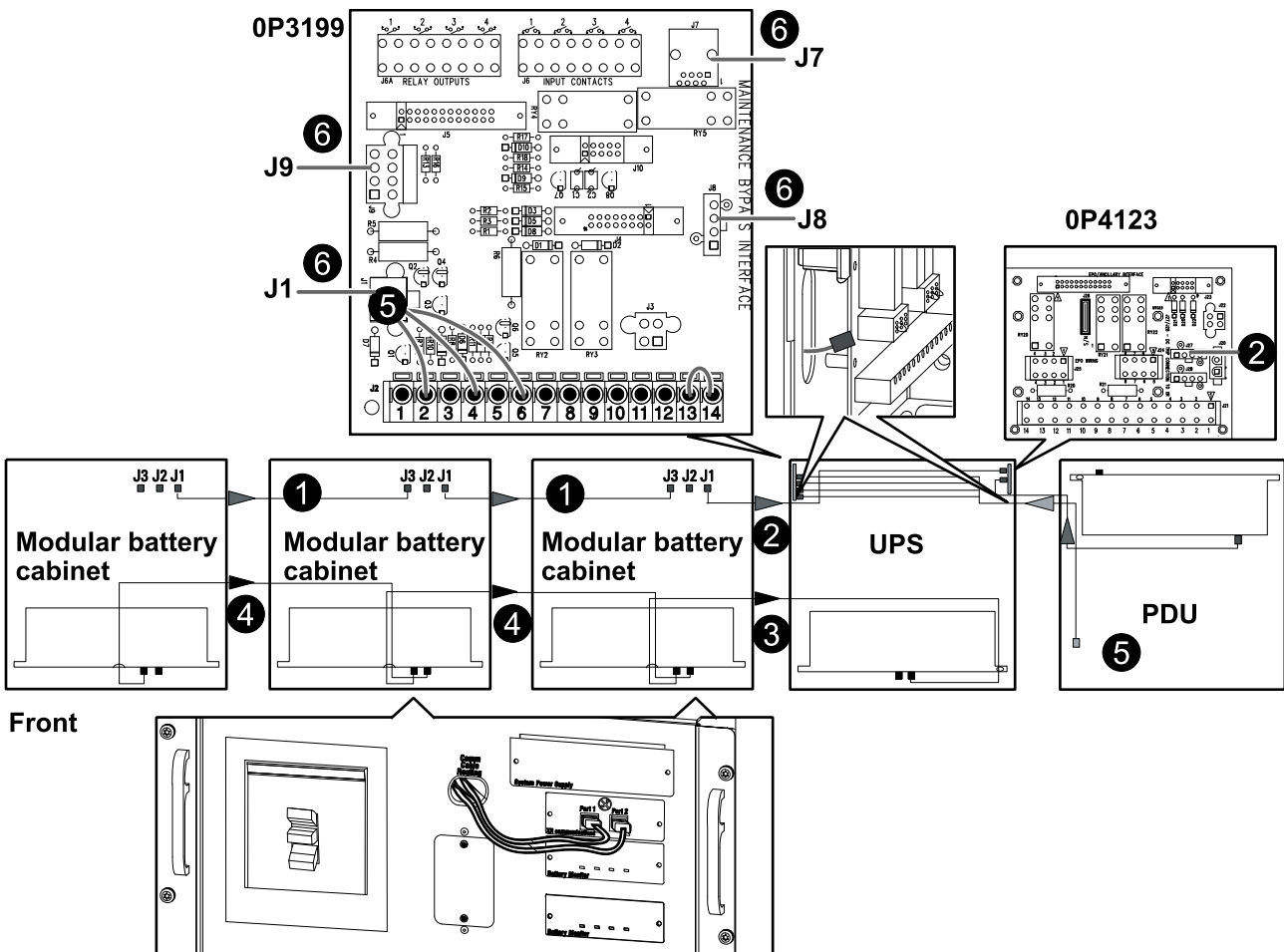

1. Route the battery breaker trip cable from J1 in the first modular battery cabinet to the J3 port in the next modular battery cabinet. Repeat the procedure for all modular battery cabinets.
2. Route the battery breaker trip cable from J1 in the last modular battery cabinet to J27 on the EPO/ancillary interface board (0P4123) in the UPS (for remote modular battery cabinet the length of the cable must not exceed 50 m).

3. Route the communication cable from the UPS XR Communications port 1 to port 2 in the first modular battery cabinet nearest the UPS in the row (for remote modular battery cabinets, the length of the communications cable from the UPS must not exceed 50 m).
4. Route the communication cable from XR Communications port 1 in each modular battery cabinet to port 2 in the next modular battery cabinet. Remove the terminator when necessary.
5. In installations with PDU, remove jumper wire harness between J1 and J2.
6. Route the four PDU communication cables from the PDU to J7, J8, J9, and J1 on the maintenance bypass interface board (0P3199) in the UPS.

Connect Network Communication Cable

1. The network communication cable (supplied) has been preconnected to the UPS and is located on the top of the cabinet. Connect the cable to your local area network.

Top view of the UPS

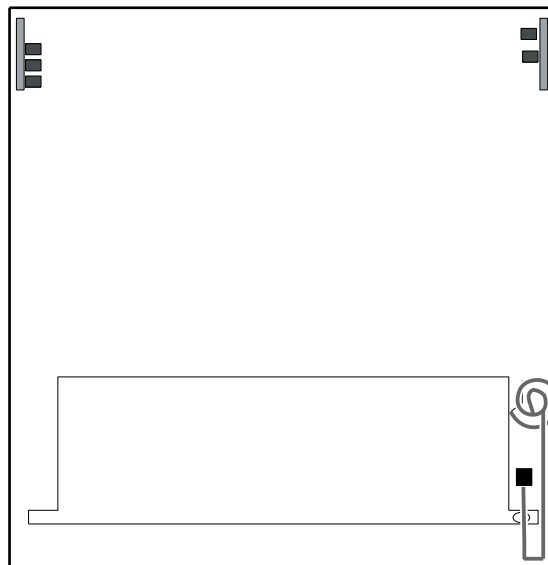

Front

Install the Symmetra PX Modular Battery Cabinet

The Symmetra PX 100 kW UPS can monitor up to four modular battery cabinets.

NOTICE
RISK OF EQUIPMENT DAMAGE
The system accepts up to 300 kcmil cables. The power terminal bolt diameter is 10 mm and the required torque value is 26 Nm (19.18 lb-ft).
Failure to follow these instructions can result in equipment damage.

NOTE: In installations with third party batteries, follow the documentation provided with the batteries.

NOTE: In remote installations, panels should be installed on free ends (part number 0M-7171D).

Connect the Battery Cables between the Modular Battery Cabinets

NOTE: For remote modular battery cabinets, the length of the signal cables must not exceed 50 m for the cable that connects the modular battery cabinet to the UPS. The length of the power cables must not exceed 200 m for the cable that connects the modular battery cabinet to the UPS. For power cables between 50 and 200 m, the voltage drop must be taken into account when the cable size is chosen. If the cables exceed the length limit this will result in erratic operation and reduced runtime.

1. In top entry systems, loosen the two top bolts and remove the eight lower bolts from the upper cover plate on the modular battery cabinet. Lift the plate to remove it.
2. Loosen the two top bolts and remove the eight lower bolts from the lower cover plate. Lift the plate to remove it.

Rear view of the modular battery cabinet

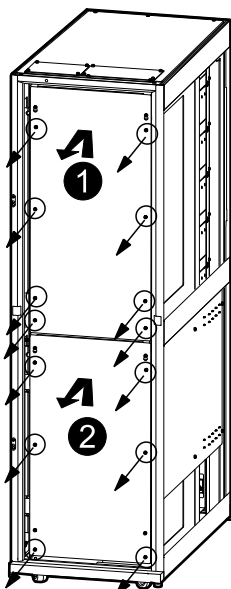

- Unwind the cables included in each modular battery cabinet. Remove the cable lugs from the cables that will connect to other modular battery cabinets. For the cables that will connect to the UPS, cut off the cable lug on the end that will be mounted in the modular battery cabinet.

Rear view of the modular battery cabinet

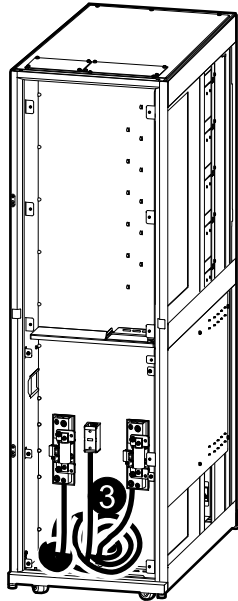

- Connect the ground cable first, and then connect BAT+, BAT-, and CT (midpoint) cables between the modular battery cabinets. Up to three modular battery cabinets can be connected in a daisy chain.

NOTICE

RISK OF LOAD DROP

If a fourth modular battery cabinet is present, it must be connected separately to the UPS. Four modular battery cabinets connected in a daisy chain at 100% load creates risk of load drop.

Failure to follow these instructions can result in equipment damage.

5. Route the ground cable and the BAT+, BAT-, and CT (midpoint) cables from the first modular battery cabinet to the UPS through the side, top, or bottom of the modular battery cabinet.

Rear view of the modular battery cabinets

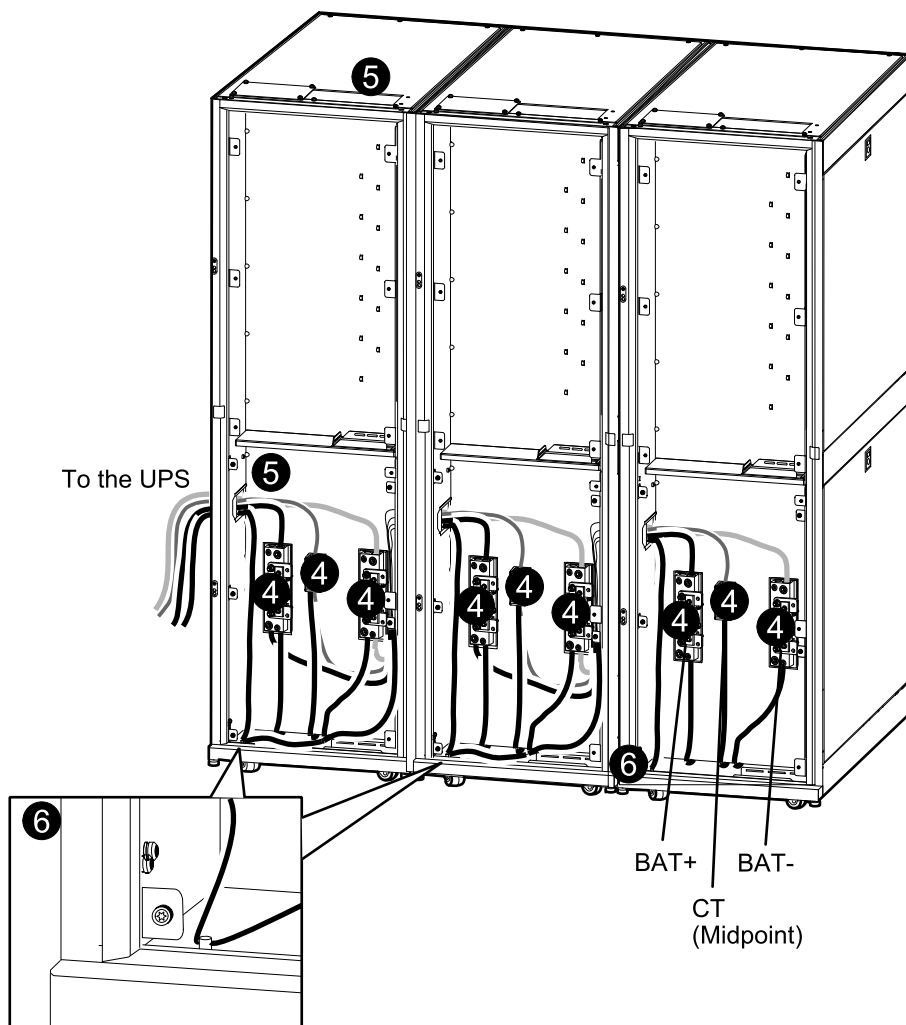

- Connect the equipment grounding cable in the modular battery cabinet that is farthest from the UPS. Route it through the other modular battery cabinets by connecting it from modular battery cabinet to modular battery cabinet to the UPS through the side, top, or bottom of the modular battery cabinet.

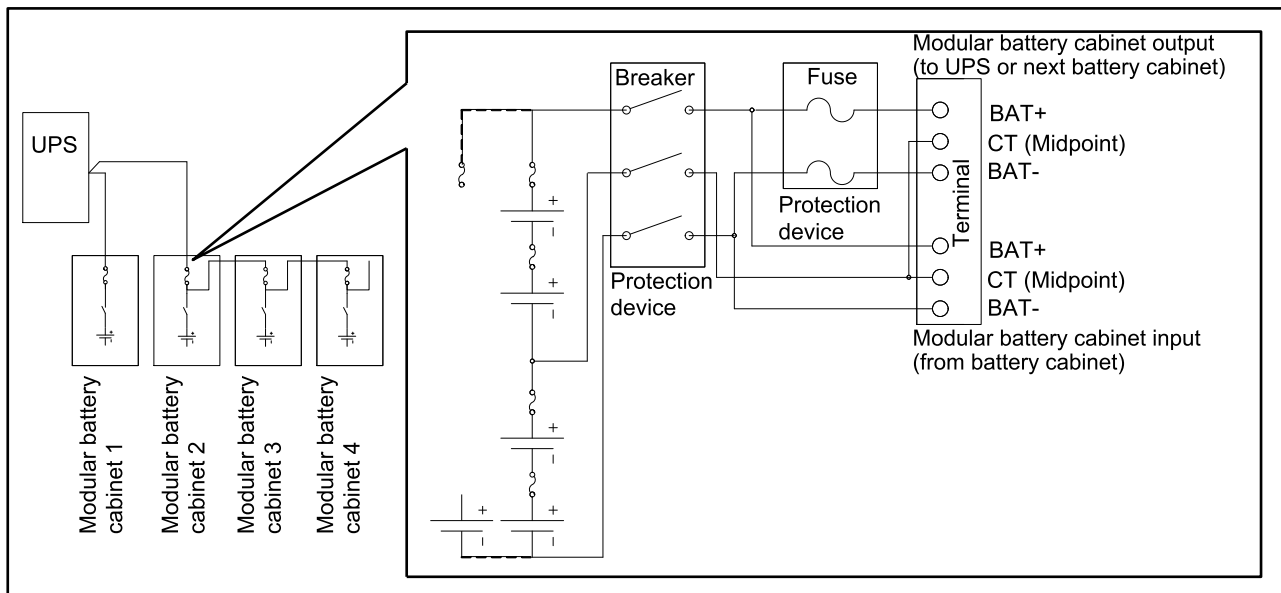

Fuse rating	300 A Class J
Breaker rating	320 A with thermal and magnetic trip-unit

- Place the cabinet address on the front of each modular battery cabinet and PDU with modular batteries (if present).

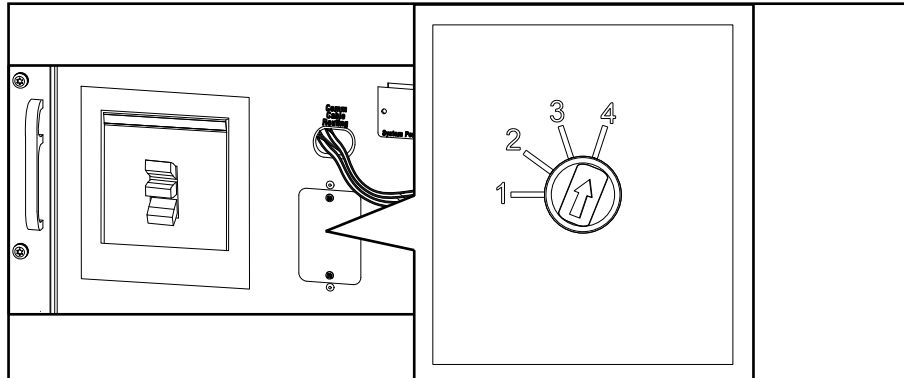

Cabinet address	UPS containing modular batteries ¹⁶	UPS not containing modular batteries
1	Modular battery cabinet 1	PDU with modular batteries/Modular battery cabinet 1
2	Modular battery cabinet 2	Modular battery cabinet 2
3	Modular battery cabinet 3	Modular battery cabinet 3
4	Modular battery cabinet 4	Modular battery cabinet 4

16. Modular batteries inside a UPS are called mainframe batteries in the display, so a UPS with modular batteries does not have a separate cabinet address.

Connect the Battery Cables to the UPS

The cables can be routed through the side, top, or bottom.

Schneider Electric recommends using a 45° cable lug. If you use straight cable lugs, install a busbar safety bracket between each busbar and cable lug to ensure a safe measure of separation. The brackets are provided with the UPS.

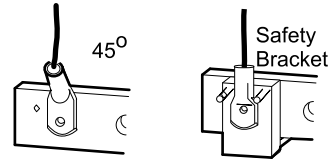

NOTE: Do not remove the 12 pcs M10 nylon hex bolts from the busbars. Mount the cables in the open holes.

NOTE: The M10 bolts, washers, and cable ties are supplied in the UPS accessory kit.

NOTE: The procedure below shows how to connect the battery cables in systems with side cable entry. In top or bottom cable entry systems, run the cables to either the top or the bottom and connect them to the busbars according to the labels.

1. Before running the cables through the side, loosen the three bolts on the cable relief next to the modular battery cabinet.
2. Route the battery cables to the UPS through the holes in the cable relief.
3. Mount the cables to the busbars according to the labels.
4. Tighten the three bolts on the cable relief.

Rear view of the UPS

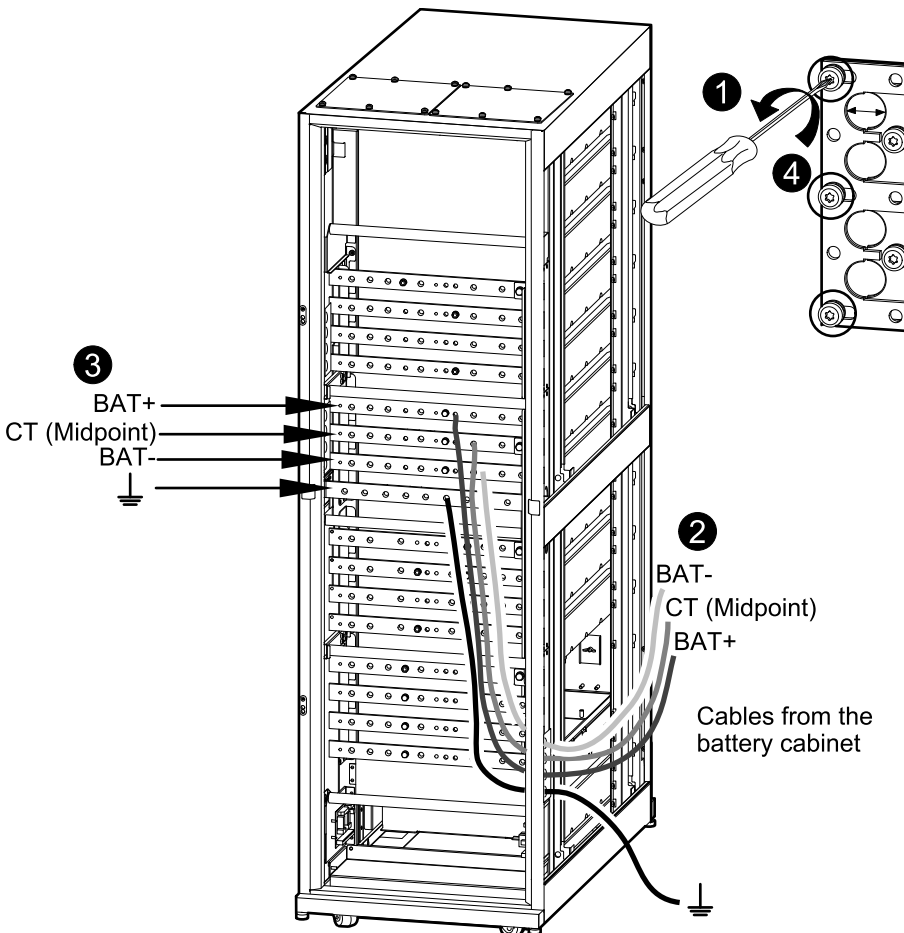

Emergency Power Off (EPO) Switch

⚠ DANGER

HAZARD OF ELECTRIC SHOCK, EXPLOSION, OR ARC FLASH

- EPO switch wiring must comply with local and national Code wiring rules. Review the planned EPO installation and operation with the local Authority Having Jurisdiction (AHJ) before proceeding with the final installation.
- Connection in spring push connectors has to be made by single solid core or multiple stranded wire terminated with a cable ferrule.
- The UPS can continue to supply AC power to the load until all AC and DC sources have been disconnected. The built-in EPO function disconnects only the internal DC sources. To fully de-energize all AC and DC power in the UPS, the upstream circuit breaker protecting the input feeder circuit to the UPS must be provided (by others) with a tripping mechanism (usually a shunt trip). The status of the upstream external circuit breaker can be monitored via the circuit breaker's aux. switch at the maintenance bypass panel interface board.
- The remote disconnect control (EPO station) must provide a dry contact signal (normally open or normally closed) to the UPS and simultaneously provide a signal to the trip mechanism on the upstream external circuit breaker feeding the UPS.

Failure to follow these instructions will result in death or serious injury.

The UPS can be connected to either a dry contact or an external 24 VDC source.

The EPO circuit is considered Class 2 and SELV (Safety Extra Low voltage). A SELV circuit is isolated from primary circuitry through an isolating transformer and designed so that under normal conditions, the voltage is limited to 42.4 V peak or 60 VDC. SELV and Class 2 circuits must be isolated from all primary circuitry. Do not connect any circuit to the EPO terminal block unless it can be confirmed that the circuit is SELV or Class 2.

Installations in the US:

- CL2Class 2 cable for general purpose use
- CL2Plenum cable for use in a vertical shaft or from floor to floor
- CL2R Racer cable for use in dwellings and raceways
- CL2XLimited use cable for dwellings and raceways

Installations in Canada:

- CL2RCertified, type ELC (Extra-Low-Voltage Control Cable)
- CL2XCertified, type ELC (Extra-Low-Voltage Control Cable)

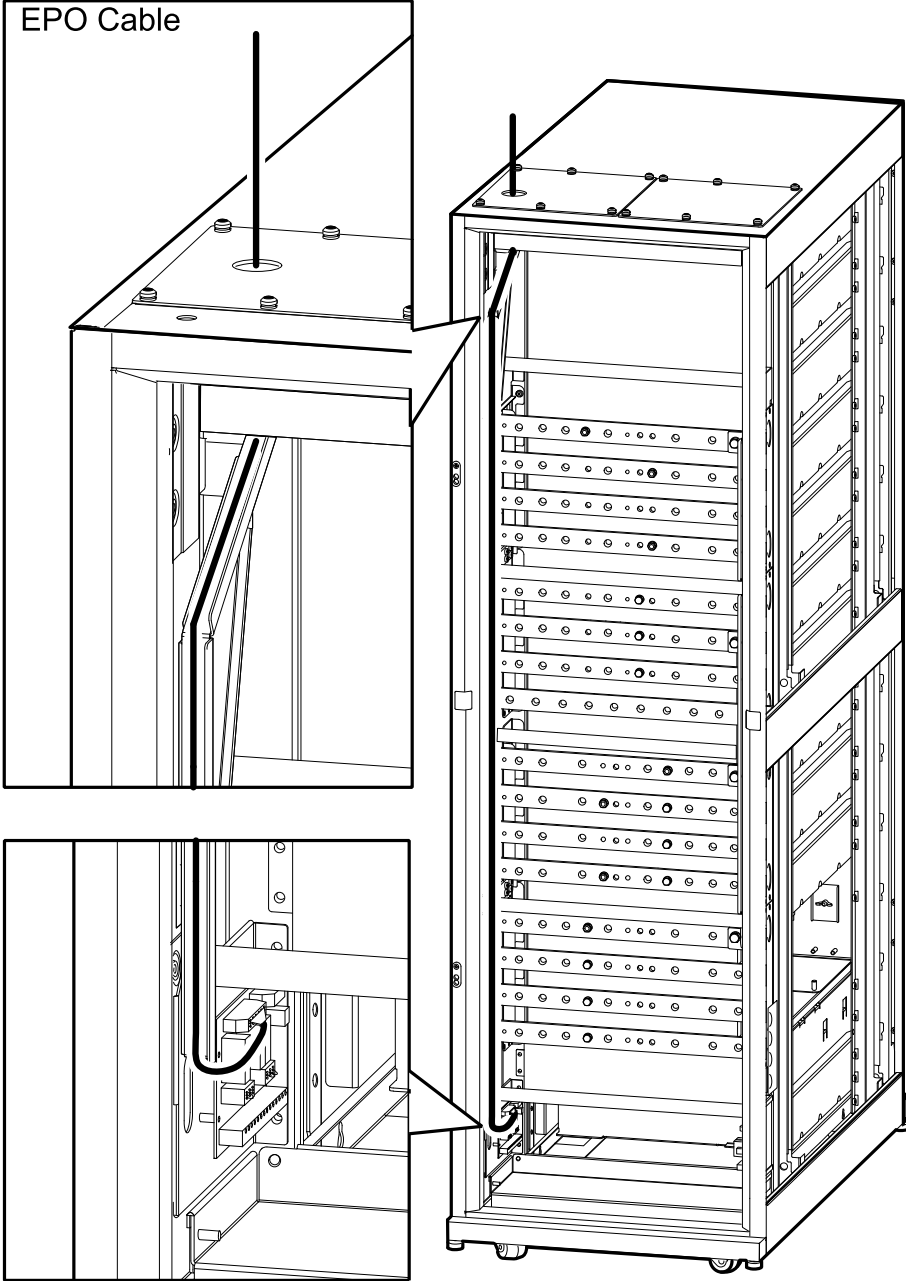

EPO and AUX Switch Wiring Diagram

NOTE: The system is configured for installations without EPO. In systems with N/O EPO, connect the EPO to J25 pin 1 and 2. In systems with N/C EPO, remove the jumper from J24 pin 5 and 6 and connect the EPO to J24 pin 5 and 6.

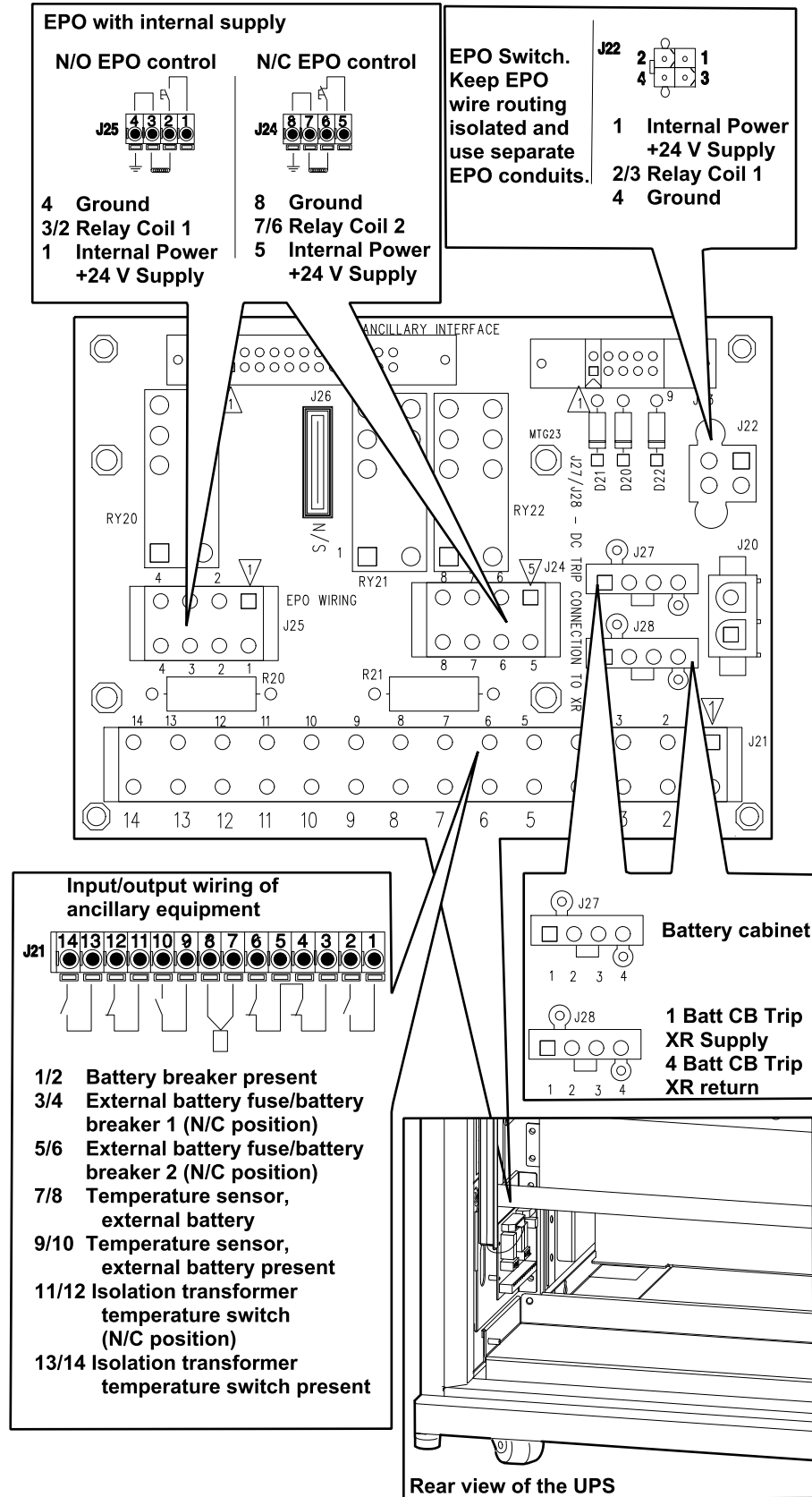

Options

Install Shunt Trip in Circuit Breaker QB in PDU (Option)

Recommended shunt trip unit models from Square D:

- S29384 for 24 VAC
- S29382 for 12 VAC
- S29390 for 24 VDC
- S29391 for 30 VDC

NOTE: This procedure details the installation and wire routing of the assembly shunt trip, for remote equipment power off. It does not detail the functioning of an emergency power off (EPO) device itself which is not provided by Schneider Electric.

⚠ DANGER

HAZARD OF ELECTRIC SHOCK, EXPLOSION, OR ARC FLASH

- For the shunt trip unit to supply a complete emergency power off (EPO) functionality, all AC voltage sources to the UPS must be interrupted.
- In a dual utility system, a shunt trip unit must be installed in both circuit breaker QB and in the upstream subfeed breaker in the PDU.

Failure to follow these instructions will result in death or serious injury.

⚠ DANGER

HAZARD OF ELECTRIC SHOCK, EXPLOSION, OR ARC FLASH

- Turn off all power supplying this equipment before working on the equipment. Perform appropriate lockout/tagout procedures.
- Service access areas are locked with a red key. The red keys must remain under the control of qualified service personnel.
- Only certified and qualified electricians are allowed to perform this installation.
- Wear appropriate personal protective equipment (PPE) and follow safe electrical work practices. See NFPA 70E

Failure to follow these instructions will result in death or serious injury.

NOTICE

- Cable rating: Use 18 AWG — 14 AWG UL listed wires, Class 2.
- Install the Class 2 wiring with separation of circuits and wiring in compliance to NFPA/NEC 70.
- The wire from the Shunt Trip Breaker to the Emergency Power Off (EPO) Circuit Breaker must not exit through the same opening as the power cables.

Failure to follow these instructions can result in equipment damage.

1. Remove all power coming into the PDU.

- Remove the panels on the PDU to access the circuit breaker QB.

Front view of PDU

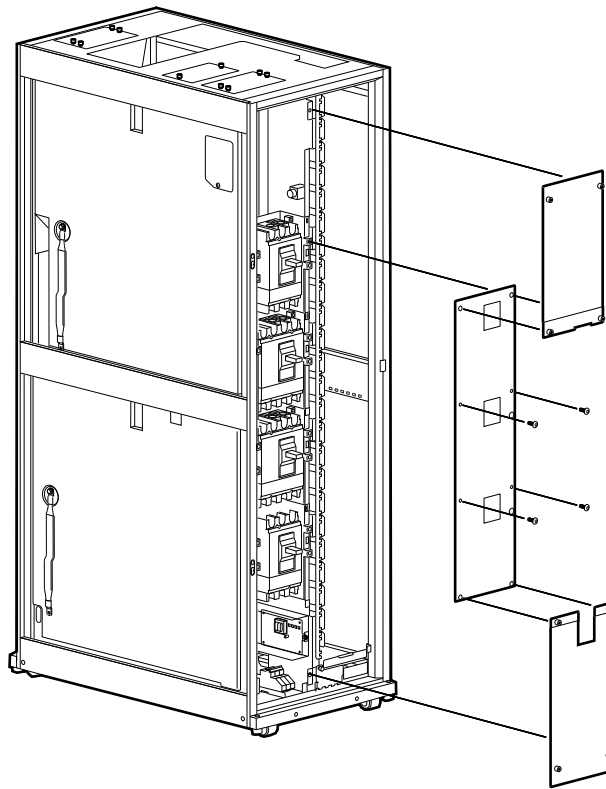

- Press the red trip button on the circuit breaker with a long screwdriver. When the circuit breaker is tripped, the handle will be located in the middle position, between the ON and OFF position.

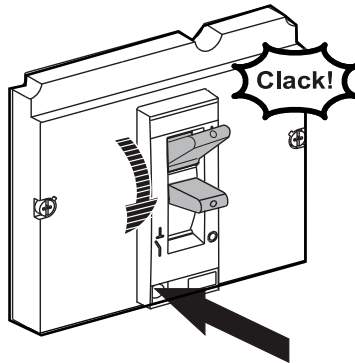

⚠ CAUTION

HAZARD OF INJURY FROM MOVING PARTS

The circuit breaker handle snaps to the tripped position very quickly when the red trip button is engaged. Use a long screwdriver to push the red trip button to avoid the circuit breaker handle striking your hand.

Failure to follow these instructions can result in injury or equipment damage.

- Remove the three screws and the cover from the circuit breaker QB. If the screws are different lengths, note their position for reinstallation.

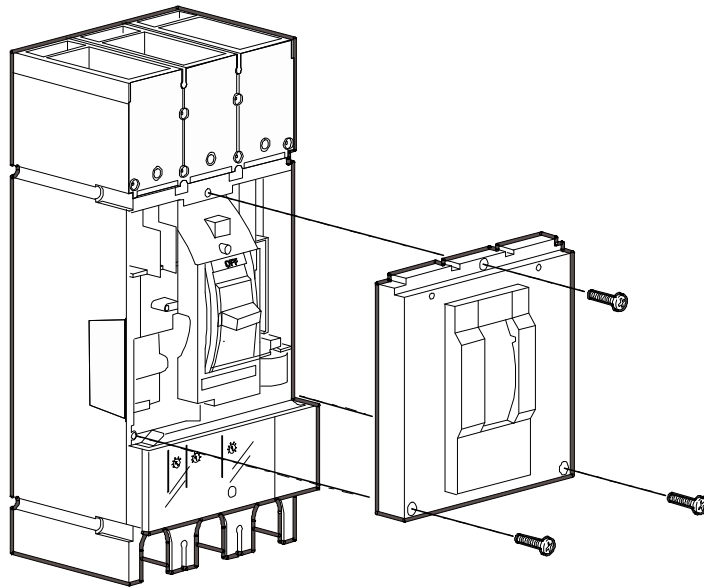

- Press the shunt trip into the lower left compartment of the circuit breaker. The shunt trip will emit an audible click when properly installed in the circuit breaker compartment.

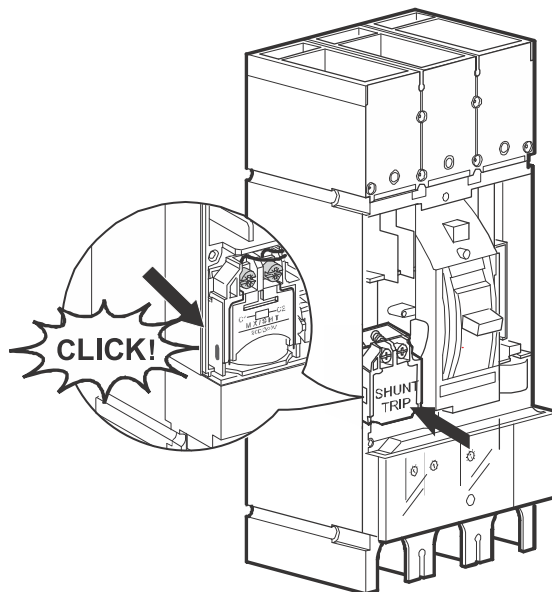

- Connect the shunt trip wires to the top of the shunt trip and tighten the screws (torque to 1.4 Nm (1.03 lb-ft)).

7. Route the shunt trip wires through the rear or the front of the circuit breaker:

- Route the shunt trip wires through the rear of the circuit breaker QB and reinstall the circuit breaker front cover and torque the three screws to 2 Nm (1.48 lb-ft), or

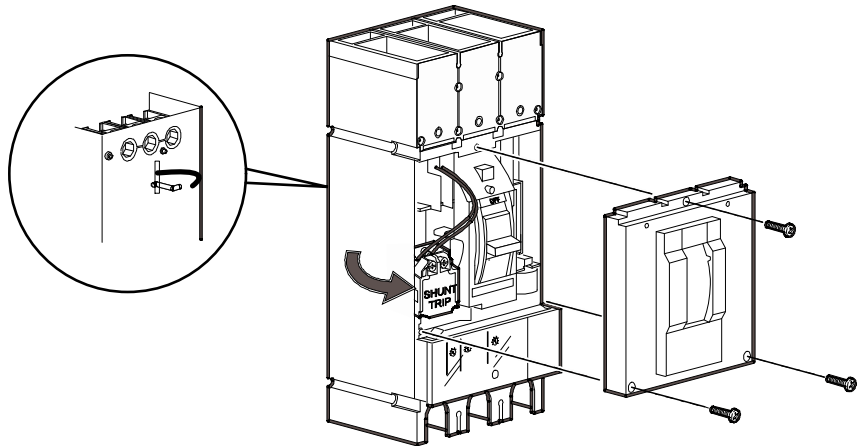

- Route the shunt trip wires out through the front of and around the circuit breaker QB. Cut a small notch in the circuit breaker front cover, reinstall the circuit breaker front cover and torque the three screws to 2 Nm (1.48 lb-ft).

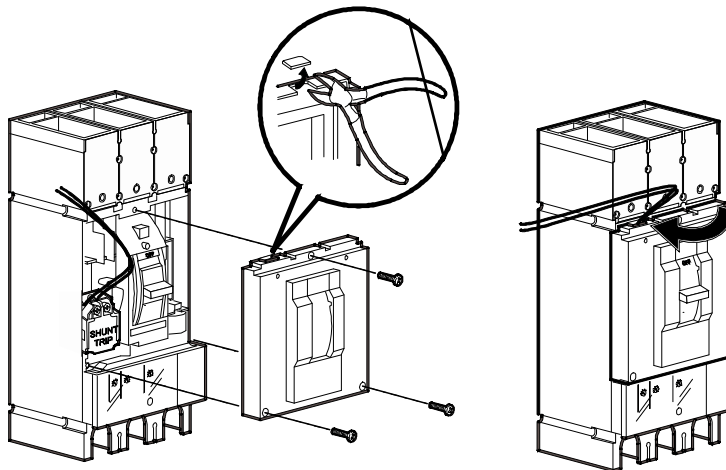

8. Remove the top cover plate of the PDU, drill appropriate holes for the shunt trip cables and reinstall the cover plate.

⚠ DANGER

HAZARD OF ELECTRIC SHOCK, EXPLOSION, OR ARC FLASH

Do not drill or cut holes for cables or conduits with the covers installed and do not drill in close proximity to the UPS or the PDU.

Failure to follow these instructions will result in death or serious injury.

Front view of PDU

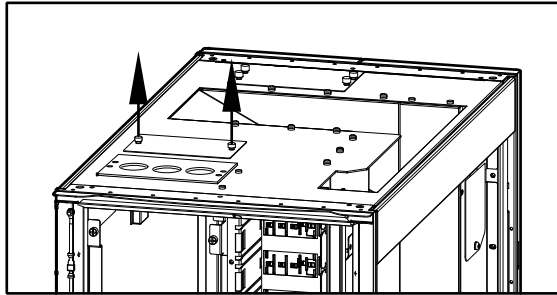

Front view of PDU

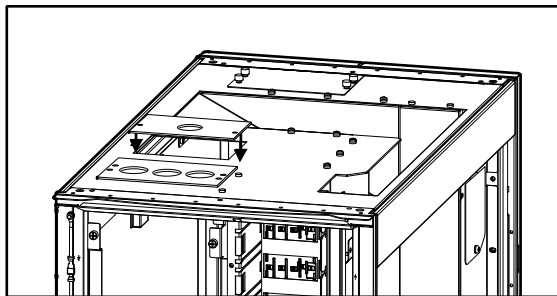

9. Route the shunt trip control cable for circuit breaker QB through the top cover plate using appropriate strain relief.

Front view of PDU

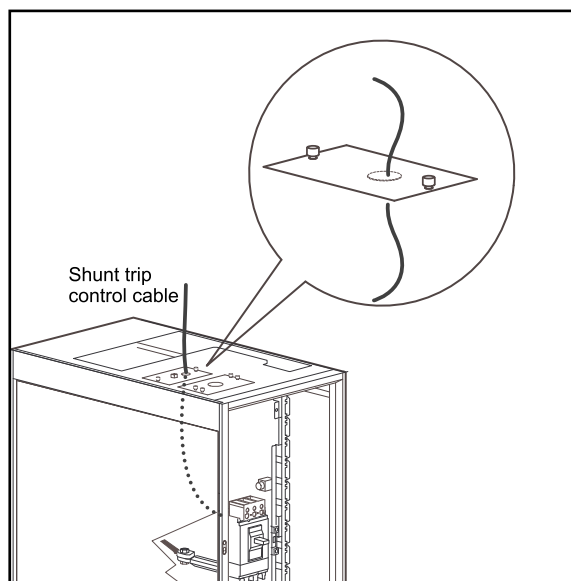

10. Secure the shunt trip control cable to the tie down slots inside the PDU with cable ties. Maintain proper spacing from the power cables.

11. Reinstall the panels on the PDU.

12. Connect the shunt trip control cables to an appropriate low voltage supply/ source and an appropriate switch (not provided).

NOTE: This low voltage supply/source **MUST** remain on and powered at all times. If it is ever off, the shunt trip will not be able to operate.

13. Set the circuit breaker QB to the ON position.
14. Reconnect power to the PDU.

Install Seismic Option

Replace the Side Panel Lock

1. Remove the side panel from the end of row cabinets.

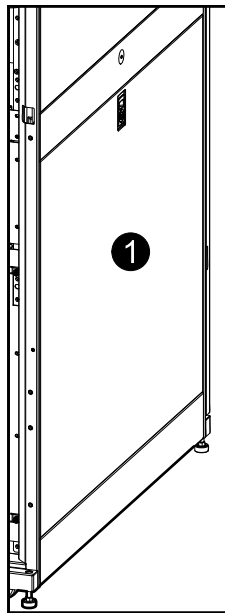

2. Use a screwdriver to press in the tab that secures the lock to the side panel.

3. Pull the lock out and up and remove it from the side panel.

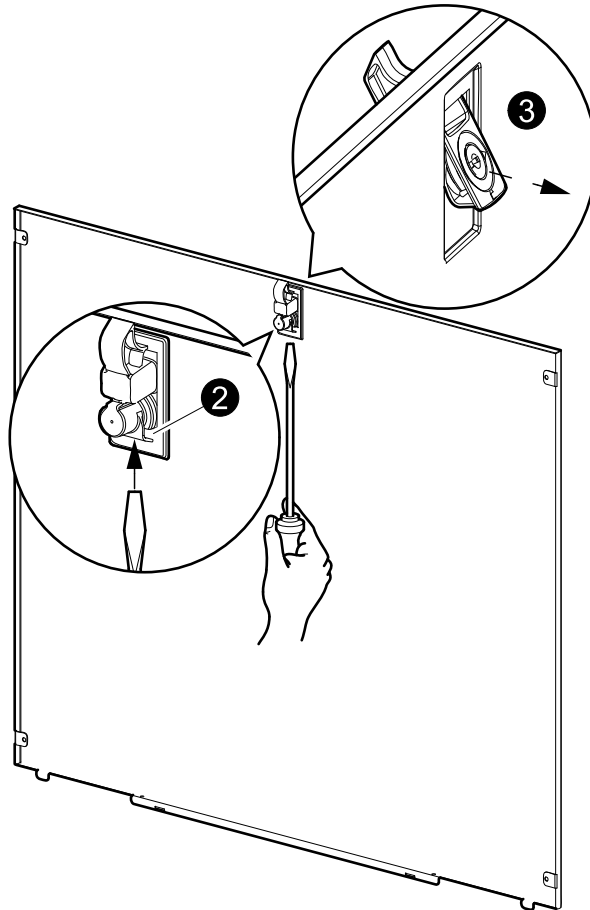

4. Take the two seismic lock parts and put them together.
5. Put in the screws but do not tighten completely.

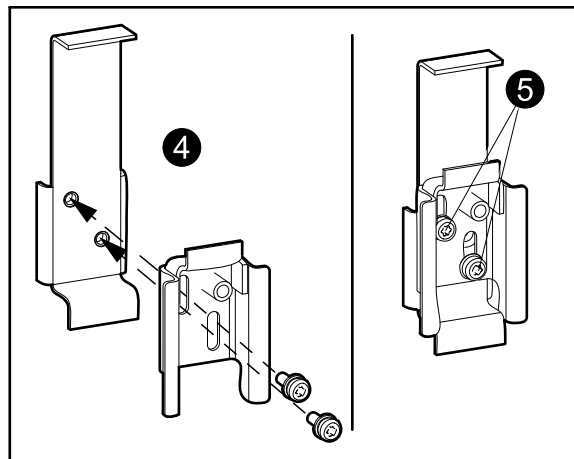

6. Place the side panel at an angle at the bottom of the frame.

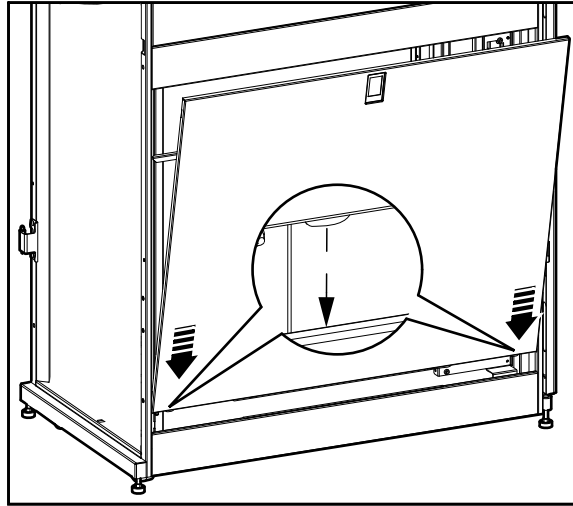

7. Push the top of the side panel in place.

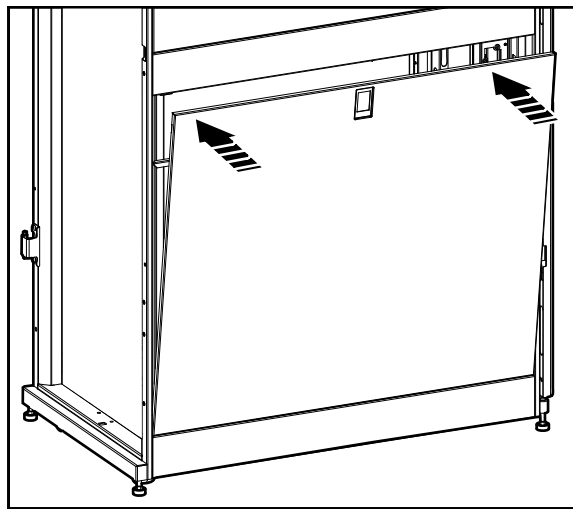

8. Hold the side panel with one hand.
9. Take the lock assembly and guide the top through the hole in the side panel.
10. Lift the lock assembly in place.

11. Ensure that the upper and lower tabs are hidden behind the side panel.

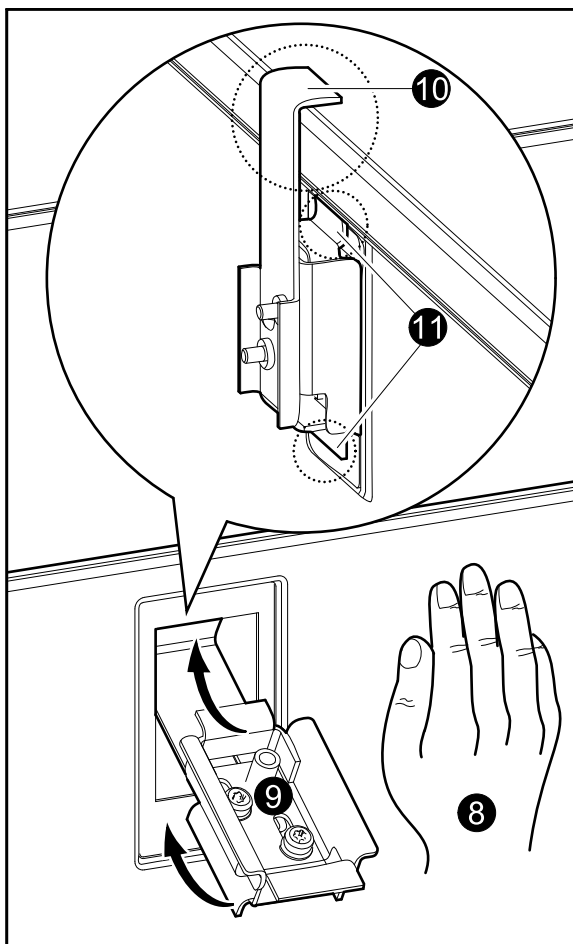

12. Tighten the two screws in the lock assembly.

13. Install the lock cover using the provided screw.

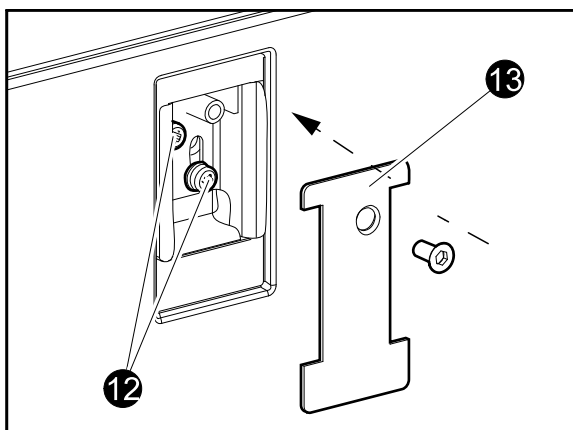

Install the Rear Anchoing Brackets

1. Secure the floor anchoring bracket to the floor using floor anchoring bolts (not supplied). Use M12 strength class 8.8 or 1/2 in grade 5 steel bolts.

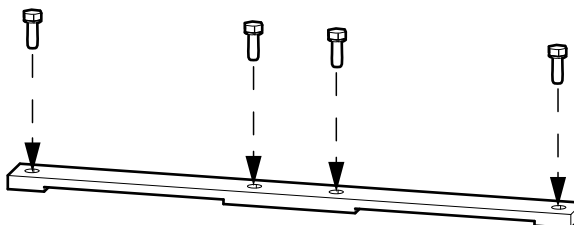

2. Secure the other part of the rear anchoring bracket to the back of the cabinet.

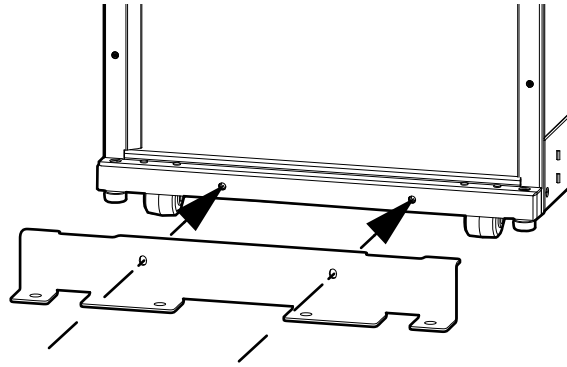

3. Push the cabinet backwards so the rear anchoring bracket on the cabinet slides under the floor anchoring bracket.

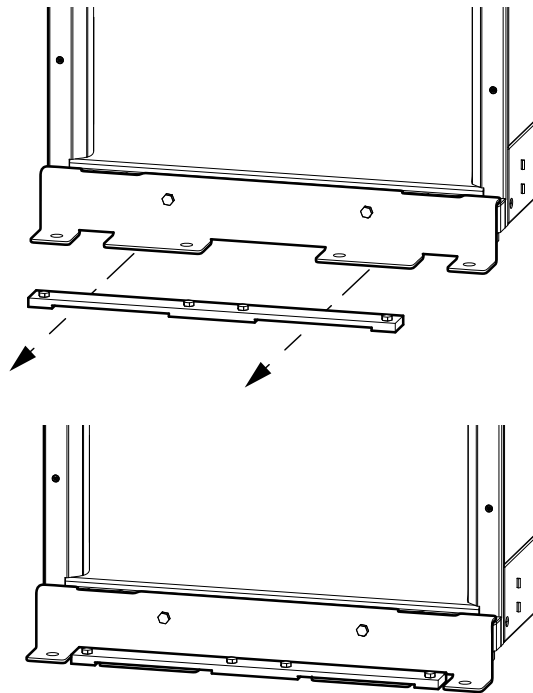

Install the Front Anchoring Bracket

1. Secure the front anchoring bracket to the cabinet.

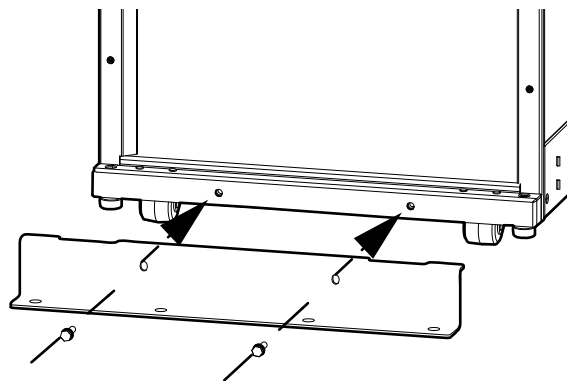

- Secure the front anchoring bracket to the floor using floor anchoring bolts (not supplied). Use M12 strength class 8.8 or 1/2 in grade 5 steel bolts.

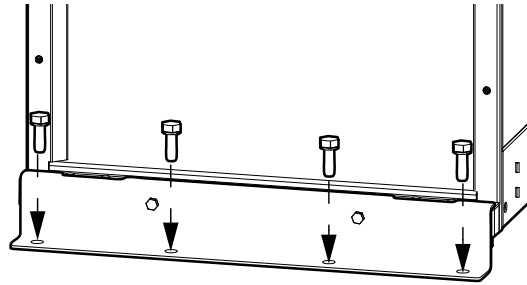

Install the Top Assembly Bracket

Required parts for each assembly:

- Two top assembly brackets
- Four screws

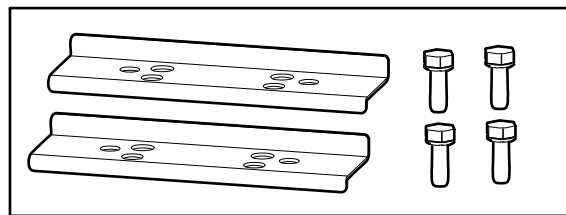

- Only applicable for Symmetra PX 100 kW systems:** Dispose of the top assembly brackets supplied with the battery cabinet.
- Place the top assembly bracket over two adjacent cabinets and secure using two screws.

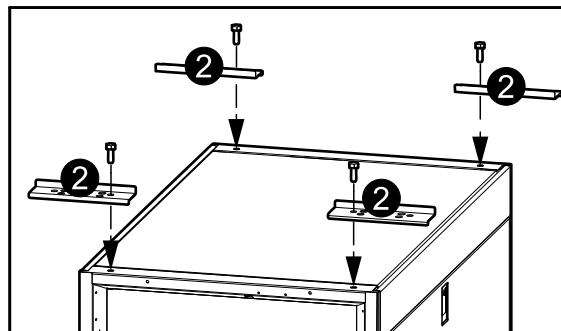

Install the Door Hinge Lock

NOTE: This procedure is only applicable for 600 mm and 750 mm wide cabinets.

Required parts:

- Two door hinge locks
- Four screws

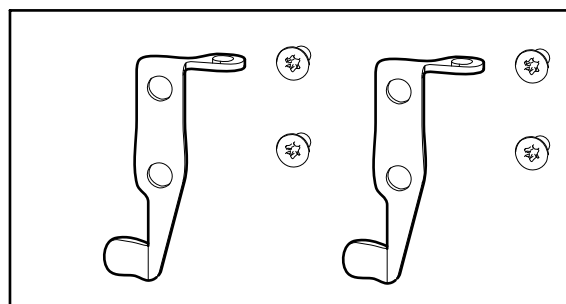

1. With one hand slide the lock into the hole below the hinge.
2. With the other hand turn the lock 90° while holding the bottom of the lock.
3. Push the lock upwards to the bottom of the hinge.
4. Secure it with the two provided screws.
5. Use the same procedure to install the upper door hinge lock.

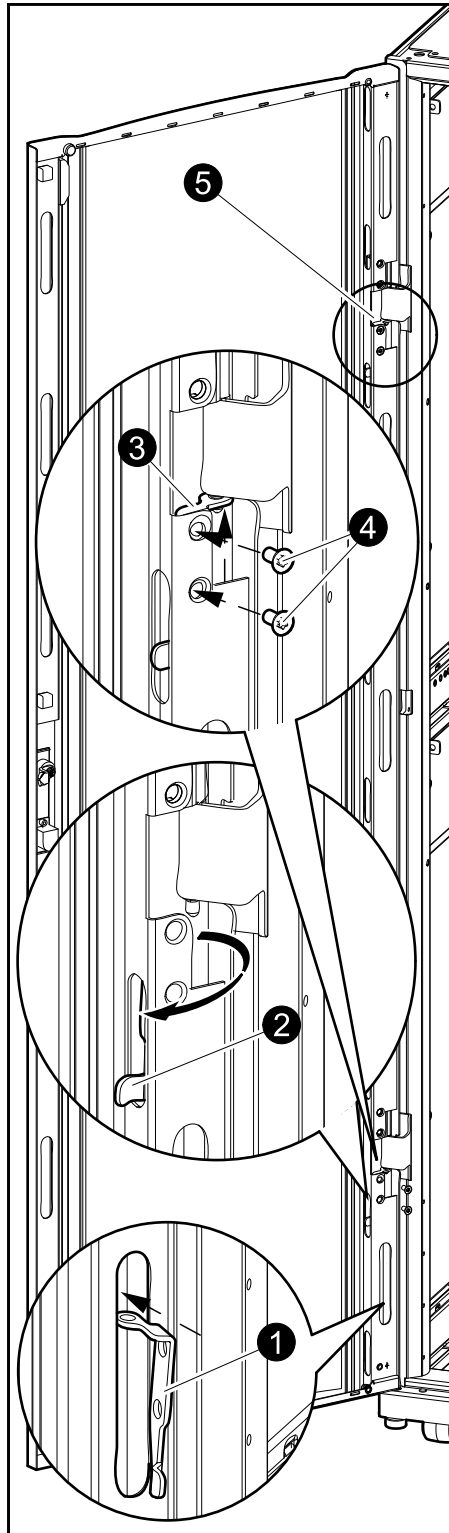

Install the Battery Locks

Required parts for each battery row:

- One battery lock
- 5 screws

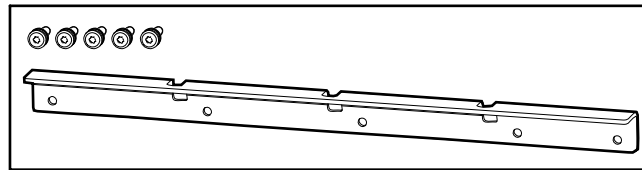

1. Place the battery lock below the battery row.
2. Secure the lock by the five provided screws.

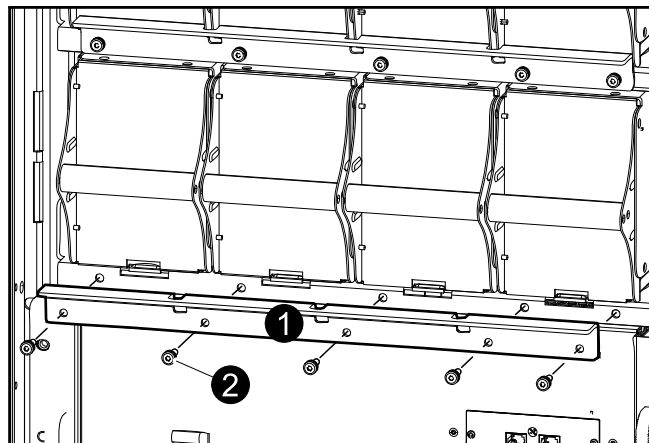

Alternative Use of the Sidecar

The sidecar can also be used as a convenient means to route overhead cables to/ from raised floor applications per NFPA/NEC 70 Article 645:

- As a bottom entry cabinet for PDU and as a cable conduit/chimney for vertical cable routing from the roof to the floor or vice versa.
- As an additional sidecar adjacent to the one above for vertical cable routing from the roof to the floor and vice versa.
- As a sidecar dedicated for vertical cable routing from the roof to the floor and vice versa adjacent to an cabinet.

1. Run the power cables through the top or bottom of the sidecar (both openings can be used if needed).

Front view of the sidecar

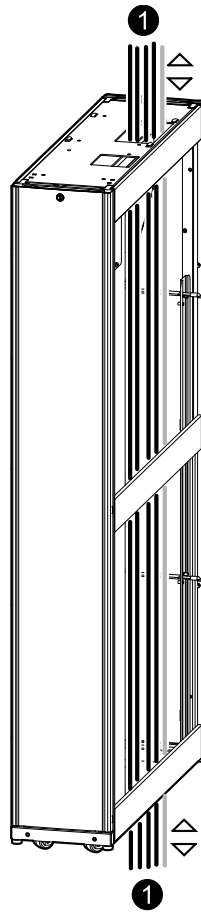

Schneider Electric
35 rue Joseph Monier
92500 Rueil Malmason
France

+ 33 (0) 1 41 29 70 00
www.schneider-electric.com

As standards, specifications, and design change from time to time, please ask for confirmation of the information given in this publication.

© 2013 – 2014 Schneider Electric. All rights reserved.
990–3659G-001